

SUBMIT BID TO:
 PROCUREMENT DEPARTMENT
 UNIVERSITY OF FLORIDA
 971 ELMORE DRIVE/ PO Box 115250
 GAINESVILLE, FL 32611-5250
 Phone: (352) 392-1335 - FAX: (352) 392-8837
 Web Address: <https://procurement.ufl.edu/>

UF UNIVERSITY of FLORIDA
INVITATION TO BID
Commodity
Acknowledgment Form

Page 1 of 17 Pages		BID WILL BE OPENED ON April 4, 2019, at 3:00PM , and may not be withdrawn within 45 days after such date and time. Mandatory pre-bid will be held March 22, 2019 at 10:00AM at the site. Questions are due by 4:00PM on March 26, 2019.		BID NO. ITB19DB-125	
UNIVERSITY MAILING DATE: 3/15/2019		PURCHASING AGENT DB / JH		BID TITLE: Hobart FT1019e Dishwashing Machine at Gator Corner	
VENDOR NAME					
VENDOR MAILING ADDRESS		REASON FOR NOT SUBMITTING BID			
CITY - STATE - ZIP CODE		POSTING OF BID TABULATIONS			
AREA CODE	TELEPHONE NO.	Bid tabulations with intended award(s) will be posted electronically for review by interested parties at https://procurement.ufl.edu and will remain posted for a period of 72 hours excluding Saturdays, Sundays, or state holidays. Failure to file a protest in accordance with Board of Governors (BOG) Regulation 18.002 or failure to post the bond or other security as required in the BOG regulations 18.002 and 18.003(3), shall constitute a waiver of protest proceedings.			
	FAX NO.				
	WEB ADDRESS				
	EMAIL ADDRESS				

I certify that this bid is made without prior understanding, agreement, or connection with any corporation, firm or person submitting a bid for the same materials, supplies, or equipment and is in all respects fair and without collusion or fraud. I agree to abide by all conditions of this bid and certify that I am authorized to sign this bid for the vendor and that the vendor is in compliance with all the requirements of the Invitation to Bid, including but not limited to, certification requirements. In submitting a bid on behalf of the Board of Trustees, hereinafter known as the University, the vendor offers and agrees that if the bid is accepted the vendor will convey, sell, assign, or transfer to the University all rights, title and interest in and to all causes of action it may now or hereafter acquire under the Anti-trust laws of the United States and the University for price fixing relating to the particular commodities or services purchased or acquired by the University. At the University's discretion, such assignment shall be made and become effective at the time the purchasing agency tenders final payment to the vendor.

 AUTHORIZED SIGNATURE (MANUAL)

 NAME AND TITLE (TYPED)

GENERAL CONDITIONS

SEALED BIDS: All bid sheets and this form must be executed and submitted in a sealed envelope. (DO NOT INCLUDE MORE THAN ONE BID PER ENVELOPE.) The face of the envelope shall contain, in addition to the above address, the date, and time of the bid opening and the bid number. Bids not submitted on the attached bid form shall be rejected. All bids are subject to the conditions specified herein. Those which do not comply with these conditions are subject to rejection.

1. **EXECUTION OF BID:** Bid must contain an original manual signature of authorized representative in the space provided above. Bid must be typed or printed in ink. Use of erasable ink is not permitted. All corrections to prices made by vendor must be initialed.

2. **NO BID:** If not submitting a bid, respond by returning only this vendor acknowledgment form, marking it "NO BID", and explain the reason in the space provided above. Failure to respond to a procurement solicitation without giving justifiable reason for such failure, nonconformance to contract conditions, or other pertinent factors deemed reasonable and valid shall be cause for removal of the supplier's name from the bid mailing list. NOTE: To qualify as a respondent, vendor must submit a "NO BID", and it must be received no later than the stated bid opening date and hour.

3. **BID OPENING:** Shall be public, on the date, location and the time specified on the bid form. It is the vendor's responsibility to assure that the bid is delivered at the proper time and place of the bid opening. Bids which for any reason are not so delivered will not be considered. A bid may not be altered after opening of the bids. NOTE: Bid tabulations will be posted electronically at <https://procurement.ufl.edu>. Bid tabulations will not be provided by telephone.

4. **PRICES, TERMS AND PAYMENT:** Firm prices shall be bid and will include all packing, handling, shipping charges, and delivery to the destination shown herein.

(a) **TAXES:** The University does not pay Federal Excise and Sales taxes on direct purchases of tangible personal property or services. The Florida Tax Exempt Number is 11-06-024056-57C. This exemption does not apply to purchases of tangible personal property or services made by vendors who use the tangible personal property or services in the performance of contracts for the improvement of University-owned real property as defined in Chapter 192, F.S.

(b) **DISCOUNTS:** Vendors are encouraged to reflect trade discounts in the unit prices quoted; however, vendors may offer a discount for prompt payment. Prompt payment discounts will not be considered in the bid award. However, every effort will be made to take the discount within the time offered.

(c) **MISTAKES:** Vendors are expected to examine the specifications, delivery schedule, bid prices, extensions, and all instructions pertaining to supplies and

services. Failure to do so will be at vendor's risk. In case of a mistake in extensions the unit price will govern.

(d) **INVOICING AND PAYMENT:** Payment will be made by the University of Florida after the items awarded to a vendor have been received, inspected, and found to comply with award specifications, free of damage or defect and properly invoiced. All invoices shall bear the purchase order number. Payment for partial shipments shall not be made unless specified. An original invoice shall be submitted. Failure to follow these instructions may result in delay in processing invoices for payment. Payment shall be made in accordance with Section 215.422 (1) (2) F.S. VENDOR OMBUDSMAN: The University's vendor ombudsman, whose duties include acting as an advocate for vendors may be experiencing problems in obtaining payment from the University, may be contacted at 352-392-1241.

(e) **ANNUAL APPROPRIATIONS:** The University's performance and obligation to pay under any contract awarded is contingent upon an annual appropriation by the Legislature.

(f) **CONDITION AND PACKAGING:** It is understood and agreed that any item offered or shipped as a result of this bid shall be a new, current standard production model available at the time of this bid. All containers shall be suitable for storage or shipment, and all prices shall include standard commercial packaging.

(g) **SAFETY STANDARDS:** Unless otherwise stipulated in the bid, all manufactured items and fabricated assemblies shall comply with applicable requirements of Occupational Safety and Health Act and any standards hereunder.

5. **CONFLICT OF INTEREST:** The award hereunder is subject to the provisions of Chapter 112, F.S. All vendors must disclose with their bid the name of any officer, director, or agent who is also an employee of the University of Florida. Further, all vendors must disclose the name of any University employee who owns, directly or indirectly, an interest of five percent (5%) or more in the vendor's firm or any of its branches.

6. **AWARDS:** As the best interest of the University may require, the right is reserved to make award(s) by individual item, group of items, all or none or a combination thereof; to reject any and all bids or waive any minor irregularity or technicality in bids received. When it is determined there is no competition to the lowest responsible vendor, evaluation of other bids are not required. Vendors are cautioned to make no assumptions unless their bid has been evaluated as being responsive.

7. **INTERPRETATIONS/DISPUTES:** Any questions concerning conditions or specifications shall be directed in writing to the Purchasing Department. Inquiries must reference the date of bid opening and bid number. No interpretations shall be considered binding unless provided in writing by the University in response to requests in full compliance with this provision.

8 NOTICE OF BID PROTEST BONDING REQUIREMENT: Any person or entity who files an action protesting a decision or an intended decision pertaining to a competitive solicitation shall at the time of filing the formal protest, post with the University a bond payable to the University in an amount equal to: 10% of the estimated value of the protestor's bid or proposal; 10% of the estimated expenditure during the contract term; \$10,000.00; or whichever is less. The bond shall be conditioned upon the payment of all costs which may be adjudged against the person or entity filing the protest action. In lieu of a bond, the University may accept a cashier's check, bank official check or money order in the amount of the bond. **FAILURE OF THE PROTESTING PERSON OR ENTITY TO FILE THE REQUIRED BOND, CASHIER'S CHECK, BANK OFFICIAL CHECK OR MONEY ORDER AT THE TIME OF THE FILING THE FORMAL PROTEST SHALL RESULT IN DENIAL OF THE PROTEST.**

9. GOVERNMENTAL RESTRICTIONS: In the event any governmental restrictions may be imposed which would necessitate alteration of the material, quality, workmanship or performance of the items offered in this bid prior to their delivery, it shall be the responsibility of the successful vendor to notify the purchaser at once, indicating in writing the specific regulation which requires an alteration. The University reserves the right to accept any such alteration, including any price adjustments occasioned thereby, or to cancel the contract at no expense to the University.

10. LEGAL REQUIREMENTS: Applicable provision of all Federal, State, county and local laws, and of all ordinances, rules and regulations shall govern development, submittal and evaluation of all bids received in response hereto and shall govern any and all claims and disputes which may arise between person(s) submitting a bid response hereto and the University, by and through its officers, employees and authorized representatives, or any other person, natural or otherwise: and lack of knowledge by any vendor shall not constitute a cognizable defense against the legal effect thereof.

11. LOBBYING: Vendor is prohibited from using funds provided under any contract or purchase order for the purpose of lobbying the Legislature or any official, officer, commission, board, authority, council, committee, or department of the executive branch or the judicial branch of state government.

12. ADVERTISING: In submitting a bid, the vendor agrees not to use the results therefrom as a part of any commercial advertising. Vendor may not use the names, logos, or trademarks of the University, its employees, or affiliates without the prior written consent of the University.

13. ASSIGNMENT: Any contract or purchase order issued pursuant to this Invitation to Bid and the monies which may become due hereunder are not assignable except with the prior written approval of the purchaser.

14. LIABILITY: The vendor agrees to indemnify and save the University of Florida, the State of Florida and the Florida Board of Governors, their officers, agents, and employees harmless from any and all judgments, orders, awards, costs and expenses, including attorney's fees, and also all claims on account of damages to property, including loss of use thereof, or bodily injury (including death) which may be hereafter sustained by the vendor, its employees, its subcontractors, or the University of Florida, the State of Florida and the Florida Board of Governors, their officers, agents, or employees, or third persons, arising out of or in connection with any contract awarded and which are the result of the vendor's breach of contract or of the negligent acts of the vendor, its officers, agents, and employees. This clause does not apply to contracts between government agencies.

15. FACILITIES: The University reserves the right to inspect the vendor's facilities at any time with prior notice.

16. ADDITIONAL QUANTITIES: For a period not exceeding ninety (90) days from the date of acceptance of any offer by the University of Florida, the right is reserved to acquire additional quantities up to but not exceeding those shown on bid or the bid level at the prices bid in this invitation. If additional quantities are not acceptable, the bid sheets must be noted "BID IS FOR SPECIFIED QUANTITY ONLY".

17. SERVICE AND WARRANTY: Unless otherwise specified, the vendor shall define any warranty service and replacements that will be provided during and subsequent to this contract. Vendors must explain on an attached sheet to what extent warranty and service facilities are provided.

18. SAMPLES: Samples of items, when called for, must be furnished free of expense, on or before bid opening time and date, and if not destroyed, may upon request, be returned at the vendor's expense. Each individual sample must be labeled with vendor's name, manufacturer's brand name and number, bid number and item reference. Request for return of samples shall be accompanied by instructions which include shipping authorization and name of carrier and must be received with the bid. If instructions are not received within this time, the commodities shall be disposed of by the University.

19. INSPECTION, ACCEPTANCE AND TITLE: Inspection and acceptance will be at destination unless otherwise provided. Title and risk of loss or damage of all items shall be the responsibility of the contract supplier until accepted by the University, unless loss or damage results from negligence by the University. The contract supplier shall be responsible for filing, processing and collecting all damage claims. However, to assist him in the expeditious handling of damage claims, the University will:

(a) Record any evidence of visible damage on all copies of the delivering carrier's Bill of Lading.

- (b) Report damage (Visible or Concealed) to the carrier and contract supplier confirming such reports in writing within 15 days of delivery, requesting that the carrier inspect the damaged merchandise.
- (c) Retain the item and its shipping container, including inner packing material until inspection is performed by the carrier, and disposition given by the contract supplier.
- (d) Provide the contract supplier with a copy of the carrier's Bill of Lading and damage inspection report.

20. PATENTS, COPYRIGHTS, TRADEMARKS, ROYALTIES and other Intellectual Property: The vendor, without exception, shall indemnify and save harmless the University and its employees from liability of any nature or kind, including cost and expenses for or on account of any copyrighted, patented, or unpatented invention, process, or article manufactured or used in the performance of the contract, including its use by the University of Florida. If the vendor uses any design, device, or materials covered by letters, patent or copyright, it is mutually agreed and understood without exception that the bid prices shall include all royalties or costs arising from the use of such design, device, or materials in any way involved in the work.

21. CONFLICT BETWEEN DOCUMENTS: If any terms and conditions contained within the documents that are a part of this ITB or resulting contract are in conflict with any other terms and conditions contained therein, then the various documents comprising this ITB or resulting contract, as applicable, shall govern in the following order of precedence: change order, purchase order, addenda, special conditions, general conditions, specifications, departmental description of work, and bid.

22. MANUFACTURERS' NAMES AND APPROVED EQUIVALENTS: Any manufacturer's names, trade names, brand names, information and/or catalog numbers listed in a specification are for information and not intended to limit competition. If bids are based on equivalent products, indicate on the bid form the manufacturer's name and number. Vendor shall submit with the bid, cuts, sketches, and descriptive literature, and/or complete specifications. Reference to literature submitted with a previous bid will not satisfy this provision. The vendor shall also explain in detail the reasons why the proposed equivalent will meet the specifications and not be considered an exception thereto. The University of Florida reserves the right to determine acceptance of item(s) as an approved equivalent. Bids which do not comply with these requirements are subject to rejection. Bids lacking any written indication of intent to quote an alternate brand will be received and considered in complete compliance with the specifications as listed on the bid form.

23. NONCONFORMANCE TO CONTRACT CONDITIONS: Items may be tested and/or inspected for compliance with specifications by any appropriate testing facilities. Should the items fail, the University may require the vendor to reimburse the University for costs incurred by the University in connection with the examination or testing. The data derived from any tests for compliance with specifications are public records and open to examination thereto in accordance with Chapter 119, F.S. Items delivered not conforming to specifications may be rejected and returned at vendor's expense. These items and items not delivered as per delivery data in bid and/or purchase order may result in vendor being found in default in which event any and all procurement costs may be charged against the defaulting vendor. Any violation of these conditions may also result in the vendor's name being removed from the University of Florida's vendor file.

24. PUBLIC RECORDS: Any material submitted in response to this Invitation to Bid will become a public document pursuant to Section 119.07 F.S. This includes material which the responding vendor might consider to be confidential or a trade secret. Any claim of confidentiality is waived upon submission, effective after opening pursuant to Section 119.07 F.S.

25. DELIVERY: Unless actual date of delivery is specified (or if specified delivery cannot be met), show number of days required to make delivery after receipt of purchase order in space provided. Delivery time may become a basis for making an award (see Special Conditions). Delivery shall be within the normal working hours of the University of Florida, Monday through Friday, unless otherwise specified.

26. PUBLIC PRINTING - PREFERENCE GIVEN PRINTING WITHIN THE STATE: The University of Florida shall give preference to vendors located within the state when awarding contracts to have materials printed, whenever such printing can be done at no greater expense than, and at a level of quality comparable to, that obtainable from a vendor located outside of the state.

(a) **CONTRACTS NOT TO BE SUBLET:** In accordance with Class B Printing Laws and Regulations "Printing shall be awarded only to printing firms. No contract shall be awarded to any broker, agent, or independent contractor offering printing manufactured by other firms or persons."

(b) **DISQUALIFICATION OF VENDOR:** Reasonable grounds for believing that a vendor is involved in more than one bid for the same work will be cause for rejection of all bids in which such vendors are believed to be involved. Any or all bids will be rejected if there is reason to believe that collusion exists between vendors. Bids in which the prices obviously are unbalanced will be subject to rejection.

(c) **TRADE CUSTOMS:** Current trade customs of the printing industry are recognized unless accepted by Special Conditions or Specifications herein.

(d) **COMMUNICATIONS:** It is expected that all materials and proofs will be picked up and delivered by the printer or his representative, unless otherwise specified. Upon request, materials will be forwarded by registered mail.

(e) **RETURN OF MATERIAL:** All copy, photos, artwork, and other materials supplied by the University of Florida must be handled carefully and returned in good condition upon completion of the job. Such return is a condition of the contract and payment will not be made until return is affected.

NON-TECHNICAL SPECIFICATIONS

(1) AWARD - Award will be made on an "All-or-None Offer Total Offer" basis. Any contract awarded pursuant to this Bid will be awarded to the single best bidder or to none at all.

(2) FLORIDA PREFERENCE—Preference for Florida Based Vendors for Purchases of Personal Property in accordance with §.287.084, Florida Statute; a preference shall be provided to vendors with a principal place of business in Florida. If the lowest responsible and responsive bid for personal property is from a vendor whose principal place of business is outside of Florida and is in a state or political subdivision thereof that grants a preference for the same purchase of personal property to a vendor in such state or political subdivision, as applicable, then the University shall grant the same preference to the Florida based vendor with the lowest responsible and responsive bid received pursuant to this Invitation to Bid.

If the lowest responsible and responsive bid is from a vendor whose principal place of business is in a state that does not grant a preference for the purchase of personal property to a vendor in such state, then the University shall grant a preference in the amount of 5 percent to the lowest and responsive Florida base vendor.

For vendors whose principal place of business is outside of Florida, such vendors must, at the time of submitting its bid, provide a written opinion from a licensed attorney in its state specifying (a) the preference(s) granted by the state or political subdivision and (b) how the preference(s) is/are calculated.

The attached Attestation of Principal Place of Business must be completed and returned with your ITB response.

(3) MANDATORY PRE-BID CONFERENCE - A mandatory pre-bid conference will be held on March 22, 2019 at 10:00AM at UF Gator Corner, 2021 Stadium Road, Gainesville, FL. The purpose of this conference is to hear any and all questions arising from this Invitation to Bid. Answers to any questions that might arise will be in the form of a written Addendum to the Invitation to Bid, prior to the bid opening. All such revisions must be acknowledged by signature and returned with the bid proposal. Failure to attend this meeting will result in the rejection of your bid.

(4) INQUIRIES - The University will not give verbal answers to inquiries regarding the specifications, or verbal instructions prior to or after the award of the bid. A verbal statement regarding same by any person shall be non-binding. The University is not liable for any increased costs resulting from the Bidder accepting verbal direction. All changes, if necessary, shall be made by written addendum to the bid.

Any explanation desired by bidders must be requested of UF Procurement Services in writing, and if an explanation is necessary, a reply shall be made in the form of an addendum. Direct all inquiries to Debbie Berrier, Procurement Agent II, dberrier@ufl.edu.

All addenda will be posted to our web site only: <https://procurement.ufl.edu/vendors/schedule-of-bids/>

Vendors who want the addenda supplied to them in another form must notify the Procurement Agent listed above of that request. Otherwise, it will be the bidder's sole responsibility to check the web site for any additional information and addenda concerning this ITB.

The University may not respond to any questions/requests for clarification that require addenda, if received after March 26, 2019 at 4:00PM.

(5) BID SUBMITTAL - All bids should include a completed and signed University of Florida Invitation to Bid Commodity Acknowledgment Form, Attestation of Principal Place of Business, Price Sheet, and any Addenda. Submit with one (1) complete original bid and one (1) electronic copy, on a flash drive or CD/DVD, in a sealed

envelope, with the following information on the outside of the envelope: Bid number (ITB19DB-125), date and time of bid opening (4/4 at 3:00PM), and company name.

BIDS ARE DUE NO LATER THAN April 4, 2019 at 3:00PM.

Bids received after this time, emailed bids or faxed bids will not be accepted.

(6) BID DELIVERY - If this bid will be mailed through the U. S. Postal Service as regular mail, address the bid to the PO Box as shown on the Invitation to Bid Commodity Acknowledgment Form.

If a company representative plans to attend the bid opening; if the bid will be hand delivered; or if the bid will be delivered by a service other than the U. S. Postal Service regular mail, i.e., Federal Express, United Parcel Service, Courier, U. S. Postal Express Mail, etc., address the bid to the street address as shown on the Invitation to Bid Commodity Acknowledgment form.

(7) ERRORS – The University is not liable for any errors or misinterpretations made by the proposer in responding to this Invitation to Bid.

(8) CONFIDENTIALITY – From the date of issuance of this ITB, until a proposal is made, the vendor must not make available or discuss his or her proposal, or any part thereof, with any employee or agent of the University, unless permitted by the UF Procurement Services, in writing, for purposes of clarification only.

(9) VENDOR'S EXPENSE – All proposals submitted in response to the ITB must be submitted at the sole expense of the Vendor, whether or not any agreement is signed as a result of this Invitation to Bid. Proposers will pay all costs associated with the preparation of proposals and necessary visits to campus and/or other required site visits.

(10) OPEN COMPETITION - The University encourages free and open competition among vendors. Whenever possible, specifications and ITB terms and conditions are designed to accomplish the objective, consistent with the necessity to satisfy the University's needs and the accomplishment of a sound economical operation. The vendor's signature on the proposal guarantees that the prices quoted have been established without collusion with other vendors and without effort to preclude the University from obtaining the lowest possible competitive price. The vendor certifies that its officers or employees have not bribed or attempted to bribe or influence in any way on officer, employee or agent of the University.

(11) QUALIFICATIONS OF BIDDERS - This bid will be awarded only to a responsible bidder qualified by experience to provide the work specified. If the bidder has not been pre-qualified with UF Procurement Services within the fiscal year (July 1 through June 30), the following evidence of eligibility may be required to be submitted:

1. Evidence that bidder is licensed by the appropriate government agency to perform the work specified.
2. Experience record showing bidder's training and experience in similar work.
3. List and briefly describe projects of similar size and/or complexity which have been completed satisfactorily. List should include names of contracts, dates of contracts, location, and names and addresses of owners.

As part of the qualifications process, the University may make inquiries and investigations, including verbal or written references from vendor's customers, to determine the ability of the vendor to offer service.

(12) RIGHT TO TERMINATE - In the event that any of the provisions of a contract resulting from the bid award are violated by the successful bidder, the University may serve written notice upon such bidder of its intention to terminate the contract. Such notice is to state the reason(s) for such intention to terminate the

contract, and unless within ten (10) days after serving such notice upon the bidder, such violation shall cease and satisfactory arrangements for correction are made, the contract shall, upon expiration of said ten (10) days, cease and terminate, but the liability of such bidder and his surety for any and all such violations(s) shall not be affected by any such termination.

(13) ASSEMBLY AND/OR PLACEMENT - It will be the responsibility of the successful bidder to supply the necessary labor and materials for the placement of all equipment as specified in the Invitation to Bid and assure proper adjustment and satisfactory operation of all features prior to acceptance by the University.

(14) PARTS AND SERVICE - Bids will be considered only on items for which parts and service are available within a six (6) hour period so that excessive downtime will not occur. Bidders should be ready to furnish information on availability of parts and service upon request by the University. The University reserves right to reject bid which cannot comply with the above criteria.

(15) DEBRIS - Successful bidder shall be responsible for the disconnection and removal of old machine per scope of work. Successful bidder shall be responsible for the prompt removal of all debris which is a result of delivery, assembly, or installation of the new machine.

(16) EQUIVALENTS - Alternatives from the manufacturer specified will not be accepted.

(17) F.O.B. POINT - The F.O.B. Point shall be the University of Florida campus, in place and ready for use in at UF Gator Corner Dining Center. Exact delivery point will be indicated on the Purchase Order.

(18) LEAD TIME – Provide estimated lead time on Price Sheet.

(19) TIME OF COMPLETION - The work to be performed under this Contract must be completed within UF's Summer A Semester. Work shall begin no sooner than May 13, 2019 and must be completed no later than June 21, 2019.

(20) WARRANTY - The successful bidder shall fully warrant all equipment furnished against defect in materials and/or workmanship for a period of thirty (30) months (18 months plus 12 month extended warranty) from date of delivery and acceptance by the University. Should any defect in materials or workmanship, excepting ordinary wear and tear, appear during the above stated warranty period, the successful bidder shall repair or replace same at no cost to the University immediately upon written notice from, University Purchasing. The successful bidder will not be liable under the above warranty for any defects or damages resulting from unforeseeable causes beyond the control and without the fault or negligence of the bidder, such as misuse or neglect by the University, acts of God, fires, floods, and hurricanes. Warranties under Chapter 672, Florida Statutes are not waived absent written agreement signed by an authorized individual at the University.

(21) MAINTENANCE AND INSTRUCTION MANUALS - The successful bidder shall include at least one copy of an instruction manual with each unit supplied. This manual shall include at least a minimum of operating instructions, maintenance and repair information, including schematic diagrams and a list of available replacement parts.

(22) PROTECTION OF PROPERTY - The successful bidder shall at all times guard against damage or loss to the property of the University or of other vendors or contractors and shall be held responsible for replacing or repairing any such loss or damage. The University may withhold payment or make such deductions as deemed necessary to insure reimbursement or replacement for loss or damage to property through negligence of the successful bidder or his agents. The contractor shall provide all barricades and take all necessary precautions to protect buildings and/or personnel.

(23) INSURANCE – The Contractor shall purchase from and maintain with a company or companies, lawfully authorized to do business in Florida and acceptable to the University, such insurance as will protect the Contractor from claims arising out of or resulting from the Contractor’s operations under the Contract and for which the Contractor may be legally liable, whether such operations be by the Contractor or by a Subcontractor or by anyone directly or indirectly employed by any of them, or by anyone for whose acts any of them may be liable. All insurance policies shall be issued and countersigned by representatives of such companies duly authorized for the State of Florida and shall be written on ISO standard forms or their equivalents. The Contractor shall file with the University Certificates of Insurance prior to the commencement of the work and shall file certificates of insurance evidencing the renewal of such policies at least thirty (30) days prior to the date the each applicable insurance policy is scheduled to expire. Please note that the University of Florida must be named “additional insured” on automobile and general liability policies.

Contractors Liability Insurance - The Contractor shall provide the ISO Commercial General Liability policy for general liability coverage’s for limits of not less than of \$500,000 per occurrence. Coverage’s shall be maintained without interruption from date of commencement of work until date of final payment.

Automobile Liability - The Contractor shall secure and maintain during the life of this Agreement, Automobile Liability insurance on all vehicles against bodily injury and property damage in the amount of at least, \$500,000 per occurrence.

Worker's Compensation - The Contractor shall secure and maintain for the life of this Agreement, valid Worker's Compensation Insurance as required by Chapter 440, Florida Statutes.

(24) OSHA REGULATIONS - It is the responsibility of the contractor to insure that ALL OSHA regulations applying to this job are adhered to at all times.

(25) LIABILITY - The University, as a public entity, is protected by sovereign immunity from tort liability, subject to a limited statutory waiver. The University will not agree to (i) indemnify or hold harmless any vendor; (ii) be liable for vendor’s attorneys’ fees under any circumstances; or (iii) binding arbitration. The Agreement shall not be construed or interpreted as (i) denying to either party any remedy or defense available to such party under the laws of the State of Florida; (ii) the consent of University or the State of Florida or their agents and agencies to be sued; or (iii) a waiver of either University’s or the State of Florida’s sovereign immunity beyond the limited waiver provided in section 768.28, Florida Statutes.

(26) CHANGES IN THE WORK - The University may order in writing extra work or make changes by altering, adding to or deducting from the work, the Contract Sum and Time of Performance being adjusted accordingly. The value of any such change shall be determined by estimate and acceptance of a lump sum. Claims by the Contractor for extra cost must be made in writing before executing the work involved.

(27) EQUAL OPPORTUNITY STATEMENT - The State Universities have established equal opportunity practices which conform to both the spirit and the letter of all laws against discrimination and prohibits discrimination based on race, creed, color, sex, age, national origin, marital status or religion. To be considered for inclusion as a supplier under this agreement, the proposer commits to the following:

1. The provisions of Executive Order 11246, September 24, 1966, and the rules, regulations and relevant orders of the Secretary of Labor are applicable to each order placed against this agreement regardless of value.
2. If the proposer expects to receive \$10,000 in orders during the first 12 months of this agreement, a complete certificate of non-segregated facilities shall be attached to the proposal response.
3. If the proposer expects to receive \$50,000 in orders during the first 12 months of this agreement and employs more than 50 people, standard form 100 (EEO-1) must be filed prior to March 1 of each year.

4. If the proposer expects to receive \$50,000 in orders during the first 12 months and employs more than 50 people, a written program for affirmative action compliance must be maintained by the proposer, subject to review upon request by the user agencies of this agreement.

(28) PUBLIC ENTITY CRIME - A person or affiliate who has been placed on the convicted vendor list by the Department of Management Services, State of Florida, may not submit a proposal on a contract to provide any goods or services, including construction, repairs, or leases and may not be awarded or perform work as a contractor, supplier, subcontractor, or consultant for the University of Florida for a period of 36 months from the date of being placed on the convicted vendor list, a "person" or "affiliate" includes any natural person or any entity, including predecessor or successor entities or any entity under the control of any natural person who is active in its management and who has been convicted of a public entity crime (Rule 6C1-3.020 FAC).

(29) FEDERAL DEBARMENT - By signing this bid, the offeror certifies, to the best of its knowledge or belief, that the offeror and its principals are not presently debarred, suspended, proposed for debarment, or declared ineligible for the award of contracts by any Federal agency; or have not within a three-year period preceding this offer, been convicted of or had a civil judgment rendered against them in connection with a public contract or subcontract; or are not criminally or civilly charged by a governmental entity with commission of offenses; or has not within a three year period preceding this offer had a contract terminated for default by any Federal agency. (Federal Acquisition Regulation 52.209-5).

(30) DISCRIMINATION – An entity or affiliate who has been placed on the discriminatory vendor list may not submit a bid on a contract to provide goods or services to a public entity, may not submit a bid on a contract with a public entity for the construction or repair of a public building or public work, may not submit bids on leases of real property to a public entity, may not award or perform work as a contractor, supplier, subcontractor or consultant under contract with any public entity, and may not transact business with any public entity.

(31) SMALL BUSINESS PROGRAM - University is an equal opportunity institution and, as such, encourages the use of small businesses, including women and minority-owned small businesses in the provision of goods and services. Small businesses should have a fair and equal opportunity to compete for dollars spent by the University. Competition ensures that prices are competitive and a broad vendor base is available. Vendor shall use good faith efforts to ensure opportunities are available to small businesses, including women and minority-owned businesses. For questions about the University's Small Business Program contact Kathey Porter, Director of Small Business and Vendor Diversity, 352-392-0380.

(32) USE OF TERMS: - The terms University of Florida, University, UF, UF Procurement Services, and Facilities Operations (Gator Corner) are used synonymously in this Invitation to Bid unless otherwise indicated. The terms vendor, proposer and contractor are used synonymously in this ITB unless otherwise indicated. The terms submittal, bid, and response are used synonymously in this ITB unless otherwise indicated.

(33) AMERICANS WITH DISABILITY ACT - If special accommodations are needed in order to attend a pre-proposal meeting or a proposal opening, contact procurement@ufl.edu, three (3) business days prior to either Mandatory Pre-Bid meeting or Bid Opening.

(34) NOTICE TO CONTRACTOR: - The University shall consider the employment by any contractor of unauthorized aliens a violation of section 274A(e) of the Immigration and Nationality Act. Such violation shall be cause for unilateral cancellation of this contract.

(35) CONTRACTOR SHALL IMPLEMENT - a drug-free workplace program in accordance with the requirements of Section 440.102, Florida Statutes.

(36) TOBACCO-FREE CAMPUS POLICY – As of July 1, 2010 the University of Florida campus has been tobacco-free. The use of cigarettes or other tobacco products in UF buildings, parking lots, or in vehicles in these areas is prohibited. The successful vendor is expected to respect this smoke free policy and fully comply with it.

(37) INVOICING AND PAYMENT TO CONTRACTOR - All invoices for payment must be submitted in accordance with my UF Payment Solutions procedure found at the following site:
<http://www.fa.ufl.edu/departments/university-disbursement-services/vouchers-expenditures-and%20payment-processes/myuf-payment-solutions/>

SCOPE OF WORK

Disconnect and remove existing Hobart FT900 Dishwashing Machine and install new Hobart FT1019e Base Steam Flight-Type Dishwashing Machine, in UF Gator Corner Dining Facility, as described in the attached specifications (machine location shown in Attachment A).

The work shall include:

- Disconnect and remove Hobart FT900 Dishwashing Machine.
 - Vendor will disconnect and remove machine from current location and load onto UF owned vehicle. Vendor will coordinate removal with UF in order to ensure UF owned vehicle is ready and available for loading.
- Install new Hobart FT1019e Base Steam Flight-Type Dishwashing Machine.
 - Deliver and install new machine as described in the attached specifications including all utility connections.
 - Run systems checks to ensure acceptable function as determined by appropriate staff at UF.
- Attached floor plan (Attachment A) shows the location of the Dish Room (current and future location of dishwasher).

Warranty:

- 18 month warranty (minimum)
- 12 month extended warranty

TECHNICAL SPECIFICATIONS



Project _____
 AIA # _____ SIS # _____
 Item # _____ Quantity _____ C.S.I. Section 114000



FT1000e BASE STEAM Flight-Type Dishwashing Machine



Advansys model shown

UL, NSF & ENERGY STAR®
 APPROVALS PENDING



Complies with EPA Reduction of Lead in Drinking Water Act 2014

Meets requirements of ASSE Standard No. 1004

SPECIFIER STATEMENT

The specified machine shall be a Hobart flight type dish machine, 58 gallons of final rinse consumption per hour, with dual rinse, hinged & insulated doors, 30" wide conveyor belt, sliding wash arms without caps, & microprocessor controls.

STANDARD FEATURES

- + Pumped rinse system (pressure gauge not required)
- + Water usage 58 gph
- + Digital controls with machine diagnostics
- + Low temperature alert
- + Hinged insulated cabinet-style doors
- + 31" access on prewash, power wash and power rinse chambers; 20" access on dual rinse and ASR chambers
- + Start and stop switches at both ends
- + Doors open indicator
- + Drains open indicator
- + Door interlocks
- + 3½ H.P. prewash, power wash, and power rinse pump motors, all TEFC
- + Capless auto clean wash arms
- + Easy to remove stainless steel scrap pans and baskets
- + 30" wide conveyor belt
- + Dual rinse
- + Front and rear panels
- + Variable speed conveyor
- + Steam booster heater
- + Configurable drain to load or unload

OPTIONS & ACCESSORIES (Available at extra cost)

- Insulated split, vertical slide-up doors
- Multiple conveyor options
- Factory mounted circuit breakers
- Correctional packages – standard, medium and maximum options (Contact Hobart for details)
- Casino packages
- 6" higher than standard chamber
- Flanged feet
- Water hammer arrestor/PRV (installed by others)
- Drain water tempering kit (installed by others)
- WS-80 water softener

FT SERIES – FT1000e BASE STEAM

Approved by _____ Date _____ Approved by _____ Date _____



FT1000e BASE STEAM Flight-Type Dishwashing Machine (Left to Right)

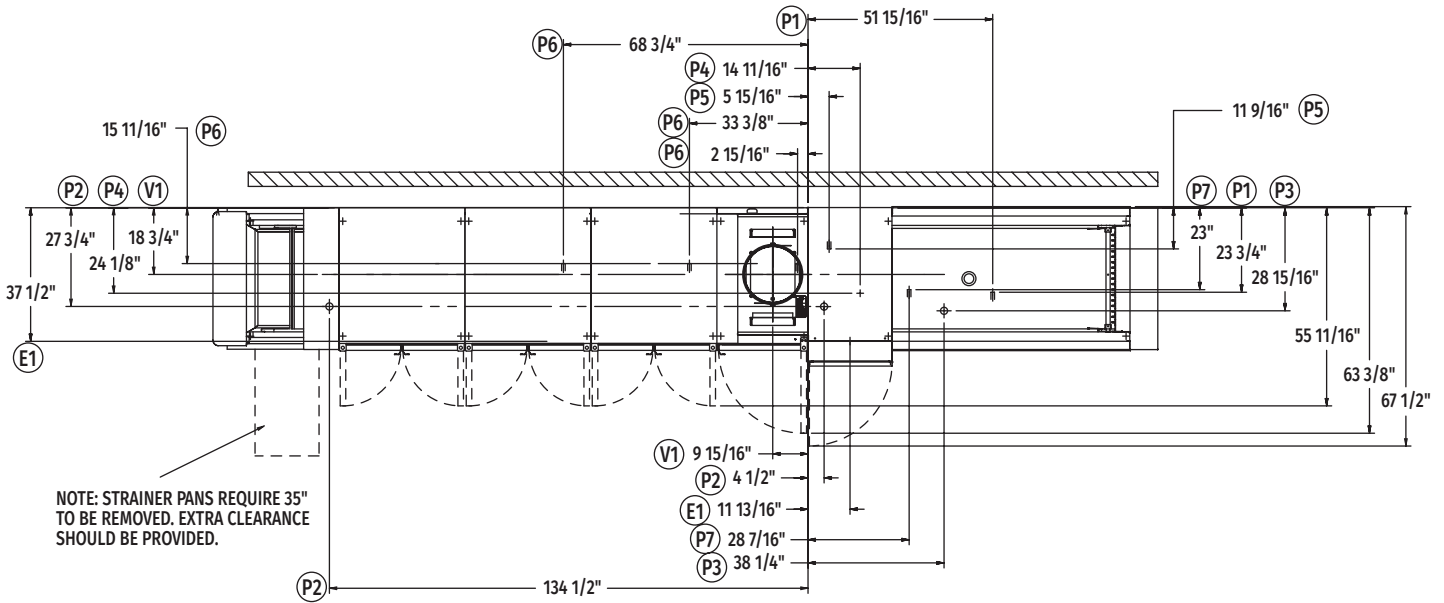

Top View Left to Right

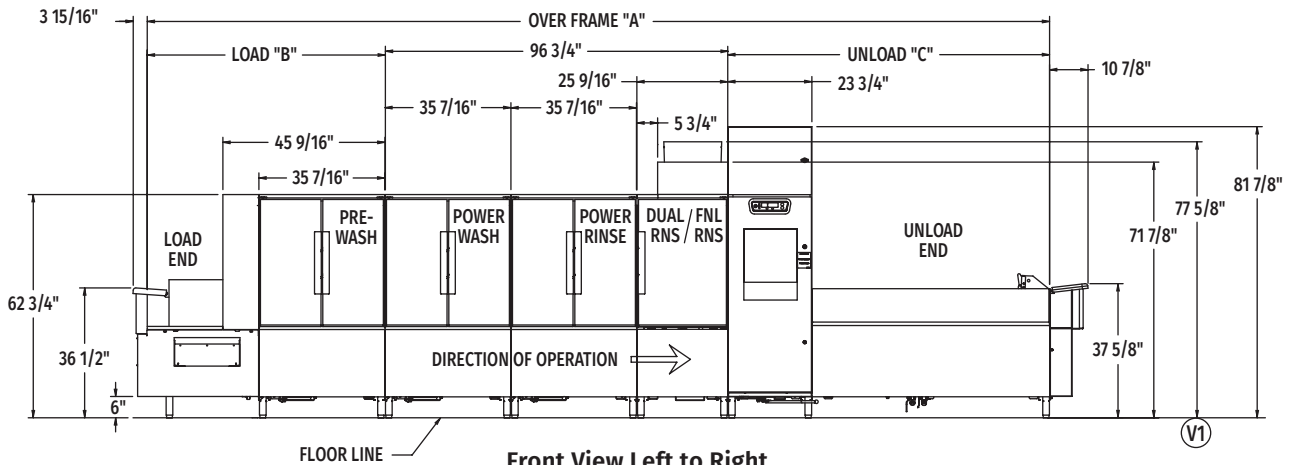

Front View Left to Right

Note: Control box electrical connections – see page 5.

MODEL NO.	"A"	"B"	"C"
FT1019e (5.5'-8'-5.5')	19' 2-3/8"	5' 6-15/16"	5' 7"
FT1020e (6.5'-8'-5.5')	20' 2-1/8"	6' 6-11/16"	5' 7"
FT1021e (7.5'-8'-5.5')	21' 1-31/32"	7' 6-17/32"	5' 7"
FT1021e (5.5'-8'-7.5')	21' 1-7/8"	5' 6-15/16"	7' 6-1/2"
FT1022e (6.5'-8'-7.5')	22' 1-5/8"	6' 6-11/16"	7' 6-1/2"
FT1023e (7.5'-8'-7.5')	23' 1-15/32"	7' 6-17/32"	7' 6-1/2"
FT1023e (5.5'-8'-9')	22' 9-5/8"	5' 6-15/16"	9' 2-1/4"
FT1024e (6.5'-8'-9')	23' 9-3/8"	6' 6-11/16"	9' 2-1/4"
FT1025e (7.5'-8'-9')	24' 9-7/32"	7' 6-17/32"	9' 2-1/4"
FT1025e (5.5'-8'-11')	24' 9-1/4"	5' 6-15/16"	11' 1-7/8"
FT1026e (6.5'-8'-11')	25' 9"	6' 6-11/16"	11' 1-7/8"
FT1027e (7.5'-8'-11')	26' 8-27/32"	7' 6-17/32"	11' 1-7/8"
FT1028e (5.5'-8'-15')	28' 4-9/16"	5' 6-15/16"	14' 9-3/16"
FT1029e (6.5'-8'-15')	29' 4-5/16"	6' 6-11/16"	14' 9-3/16"
FT1030e (7.5'-8'-15')	30' 4-5/32"	7' 6-17/32"	14' 9-3/16"
FT1030e (5.5'-8'-17')	30' 4-1/8"	5' 6-15/16"	16' 8-3/4"
FT1031e (6.5'-8'-17')	31' 3-7/8"	6' 6-11/16"	16' 8-3/4"
FT1032e (7.5'-8'-17')	32' 3-23/32"	7' 6-17/32"	16' 8-3/4"

Note: Overall length of machine is Dimension "A" + 14-13/16"

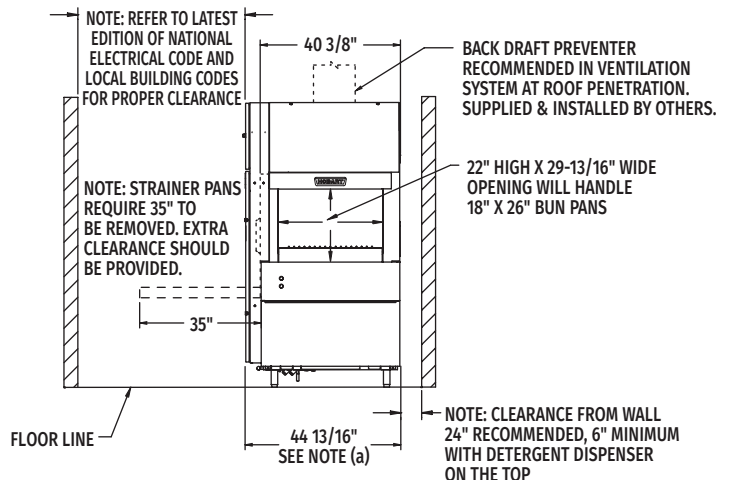

Back/Unload End

MODEL: FT1000e BASE STEAM L-R OPERATION 00-562361 REV B



FT1000e BASE STEAM

Flight-Type Dishwashing Machine

(Right to Left)

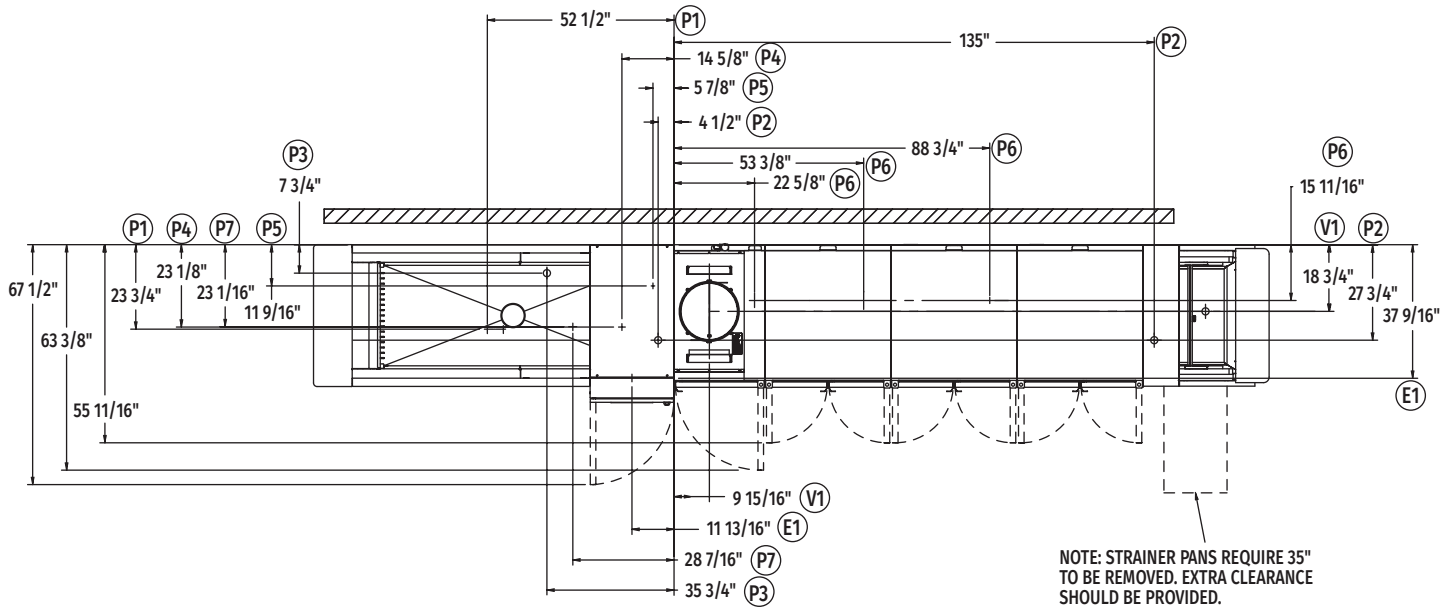

Top View Right to Left

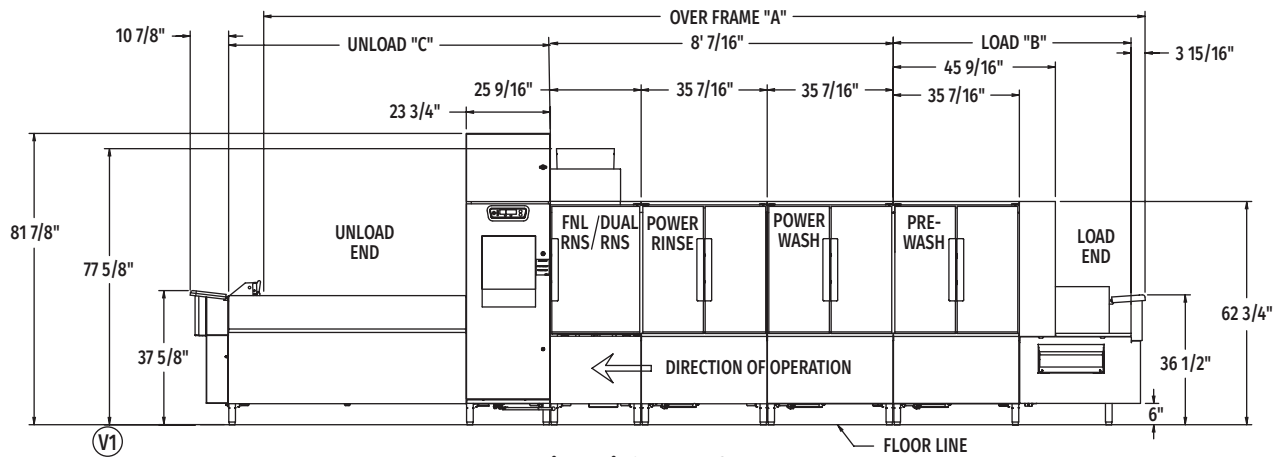

Front View Right to Left

Note: Control box electrical connections – see page 5.

MODEL NO.	"A"	"B"	"C"
FT1019e (5.5'-8'-5.5')	19' 2-3/8"	5' 6-15/16"	5' 7"
FT1020e (6.5'-8'-5.5')	20' 2-1/8"	6' 6-11/16"	5' 7"
FT1021e (7.5'-8'-5.5')	21' 1-31/32"	7' 6-17/32"	5' 7"
FT1021e (5.5'-8'-7.5')	21' 1-7/8"	5' 6-15/16"	7' 6-1/2"
FT1022e (6.5'-8'-7.5')	22' 1-5/8"	6' 6-11/16"	7' 6-1/2"
FT1023e (7.5'-8'-7.5')	23' 1-15/32"	7' 6-17/32"	7' 6-1/2"
FT1023e (5.5'-8'-9')	22' 9-5/8"	5' 6-15/16"	9' 2-1/4"
FT1024e (6.5'-8'-9')	23' 9-3/8"	6' 6-11/16"	9' 2-1/4"
FT1025e (7.5'-8'-9')	24' 9-7/32"	7' 6-17/32"	9' 2-1/4"
FT1025e (5.5'-8'-11')	24' 9-1/4"	5' 6-15/16"	11' 1-7/8"
FT1026e (6.5'-8'-11')	25' 9"	6' 6-11/16"	11' 1-7/8"
FT1027e (7.5'-8'-11')	26' 8-27/32"	7' 6-17/32"	11' 1-7/8"
FT1028e (5.5'-8'-15')	28' 4-9/16"	5' 6-15/16"	14' 9-3/16"
FT1029e (6.5'-8'-15')	29' 4-5/16"	6' 6-11/16"	14' 9-3/16"
FT1030e (7.5'-8'-15')	30' 4-5/32"	7' 6-17/32"	14' 9-3/16"
FT1030e (5.5'-8'-17')	30' 4-1/8"	5' 6-15/16"	16' 8-3/4"
FT1031e (6.5'-8'-17')	31' 3-7/8"	6' 6-11/16"	16' 8-3/4"
FT1032e (7.5'-8'-17')	32' 3-23/32"	7' 6-17/32"	16' 8-3/4"

Note: Overall length of machine is Dimension "A" + 14-13/16"

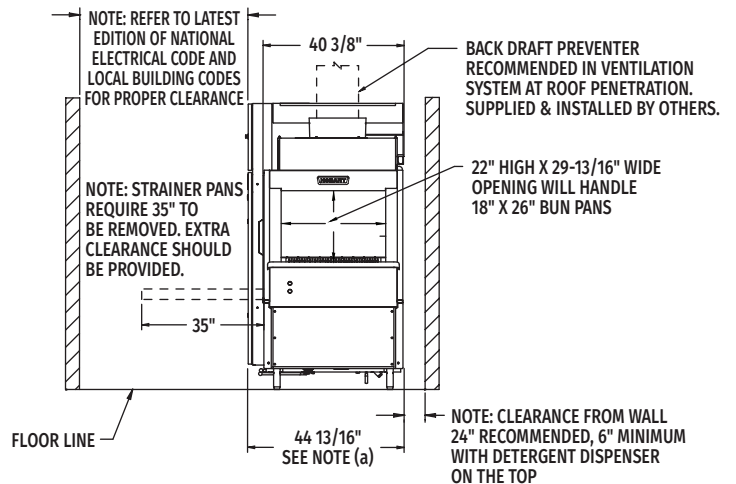

Back/Unload End

MODEL:
FT1000e BASE
STEAM
R-L OPERATION
00-562360
REV B



FT1000e BASE STEAM Flight-Type Dishwashing Machine

LEGEND

Electrical Connections	
E1	Electric connection for 1TB with or without circuit breakers. 79-1/8" AFF.
Plumbing Connections	
P1	Common hot water connection (automatic fill) 110°F water minimum, 1" FPT, 5-1/2" AFF.
P2	Drain connection: May be drained to either end of unit. Default location is drain to unload unless otherwise indicated. 2" FPT, 7" AFF.
P3	Common steam connection (tank heat & steam booster). 1-1/2" FPT, 7" AFF (12-45 PSI flowing pressure).
P4	Steam relief valve, 1" FPT, must be piped to open drain receiver in the floor. 16-15/16" AFF.
P5	Hot relief valve (when steam booster option is specified) 3/4" FPT, must be piped to open drain receiver in the floor. 15-9/16" AFF.
P6	Condensate return, gravity connection (tank heat), bucket type traps furnished, 3 connections. 3/4" FPT, 11" AFF.
P7	Condensate return, gravity connection (when steam booster option is specified), bucket type trap furnished. 3/4" FPT, 4-3/4" AFF.
Ventilation Connections	
V1	Customers' vent connection. Must fit inside 16" diameter vent stack providing 750 CFM exhaust at machine connection @ .75" water column (standard air conditions). 77-5/8" AFF.

WARNING: Plumbing and electrical connections should be made by qualified personnel who will observe all the applicable plumbing, sanitary, safety codes and National Electrical Code.

General Notes:

(a) The control box is attached to the center section and is rotated 90 degrees for shipping.

AFF = Above Finished Floor

All dimensions taken from the floor line may increase 3-1/4" with leg adjustment.

For convenience when cleaning, customer should install water tap near machine with 30 ft. of heavy duty hose with squeeze valve.

This drawing is supplied as a reference for connection information only. It will not be utilized for manufacturing of unit.

Electrical Warning:

Service wire temperature rating: 90°C minimum.

Plumbing Notes:

Recommended building flowing hot water pressure to the dishwasher is 30-35 PSI.

Water hammer arrestor (meeting ASSE-1010 standard or equivalent) to be supplied (by others) in hot water supply line at service connection.

If steam pressure is less than 12 psi flowing pressure at the dishwasher, contact sales engineering.

Ventilation Notes:

Room ventilation is required to handle machine's latent & sensible heat. Majority of latent/sensible heat at unload end of machine.

Water Quality Required:

For best results – Total water hardness < 3 grains per gallon.

For best results – Total suspended solids (TSS) < 10 microns.

Heat Gain to Space (BTU/Hr.)	
Latent	Sensible
86,700	37,200



FT1000e BASE STEAM Flight-Type Dishwashing Machine

SERVICE CONNECTION WITH AND WITHOUT CIRCUIT BREAKERS (1 CONNECTION)

Motors & Controls (1TB) (1) Service Connection as Shown Below				
E1	Voltage	Rated Amps	Minimum Supply Circuit Ampacity	Maximum Protective Device
	208-240/60/3	38.0	50	50
	480/60/3	23.1	30	30

FT1000 Advansys Water Treatment System	
Model	Description
WS-80	Water Softener
Available through Hobart Service only	
PF-10-EHT	Hi-Temp Filter Housing
SD-510HT	Sediment Filter Cartridge

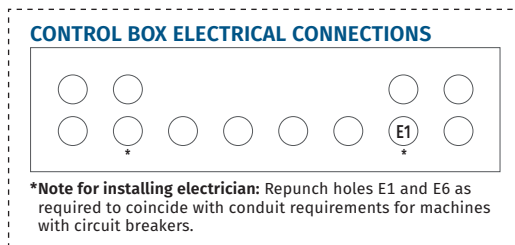

Detail "A-A"
(not to scale)

SPECIFICATIONS

Capacities

Conveyor Speed (feet per minute)	4.0 - 8.5
Dishes per Hour	14,316
Pre-Wash Tank (U.S. gallons)	40
Wash Tank (U.S. gallons)	40
Rinse	40
Dual Rinse Tank (U.S. gallons)	7.2

Motor Horsepower

Pre-Wash Tank	3½
Wash Tank	3½
Rinse Tank	3½
Dual Rinse Tank	¾
Final Rinse	½
Conveyor	¾

Water Consumption

U.S. Gallons per Hour (maximum use)	58
U.S. Gallons per Minute	0.97

Steam Consumption – Tank Heat

Pounds per Hour (maximum)	215
Regulated – based on 12 to 45 PSI steam at the machine.	
150°F wash minimum – 160°F rinse minimum –	
160°F dual rinse minimum)	

Steam Consumption – Booster Heater

Pounds per Hour (maximum)	47
(If used on 20 PSI steam, 110°F entering water raised to 185°F rinse minimum)	

Shipping Weight (approximate) . . . Varies by individual model
(Consult your Hobart representative)

Crated Dimensions Varies by individual model
(Consult your Hobart representative)

As continued product improvement is a policy of Hobart, specifications are subject to change without notice.

Attestation of Principal Place of Business

University of Florida ITB19DB-125, Hobart FT1019e Dishwashing Machine at Gator Corner

Name of Bidder: _____ Business Name: _____

Identify the State in which the Bidder has its principal place of business: _____

Bidder's Signature: _____ Title: _____

INSTRUCTIONS: IF your principal place of business above is located within the State of Florida, provide the information as indicated above and return this form with your bid response. No further action is required. IF your principal place of business is outside of the State of Florida, the following must be completed by an attorney and returned with your bid response. Failure to comply may be considered as non-responsive to the terms of this solicitation.

OPINION OF OUT-OF-STATE BIDDER'S ATTORNEY ON BIDDING PREFERENCES

(To be completed by the Attorney for an Out-of-State Bidder)

NOTICE: §287.084(2), Florida Statutes, provides that "a vendor whose principal place of business is outside this state must accompany any written bid, proposal, or reply documents with a written opinion of an attorney at law licensed to practice law in that foreign state, as to the preferences, if any or none, granted by the law of that state [or political subdivision thereof] to its own business entities whose principal places of business are in that foreign state in the letting of any or all public contracts." See also § 287.084(1), Florida Statutes.

LEGAL OPINION ABOUT STATE BIDDING PREFERENCES

(Please Select One)

_____ The Bidder's principal place of business is in the State of _____ and it is my legal opinion that the laws of that state **do not grant a preference** in the letting of any or all public contracts to business entities whose principal places of business are in that state.

_____ The Bidder's principal place of business is in the State of _____ and it is my legal opinion that the laws of that state **grant the following preference(s)** in the letting of any or all public contracts to business entities whose principal places of business are in that State: [Please describe applicable preference(s) and identify applicable state law(s)]:

LEGAL OPINION ABOUT POLITICAL SUBDIVISION BIDDING PREFERENCES

(Please Select One)

_____ The Bidder's principal place of business is in the political subdivision of _____ and it is my legal opinion that the laws of that political subdivision **do not grant a preference** in the letting of any or all public contracts to business entities whose principal places of business are in that political subdivision.

_____ The Bidder's principal place of business is in the political subdivision of _____ and it is my legal opinion that the laws of that political subdivision **grant the following preference(s)** in the letting of any or all public contracts to business entities whose principal places of business are in that political subdivision: [Please describe applicable preference(s) and identify applicable authority granting the preference(s)]:

Signature of out-of-state Bidder's attorney: _____

Printed name of out-of-state Bidder's attorney: _____

Address of out-of-state Bidder's attorney: _____

Telephone number of out-of-state Bidder's attorney: (_____) _____ - _____

Email address of out-of-state Bidder's attorney: _____

Attorney's states of bar admission: _____

PRICE SHEET

From: _____
(Company Name/Name & Title of Authorized Agent)

To: **UNIVERSITY OF FLORIDA**
Procurement Services
971 Elmore Drive/PO Box 115250
Gainesville, FL 32611

The undersigned, being invested with the authority of his/her employer, and having read the Documents for the Bid, as well as the Specifications for the Bid, entitled:

ITB19DB-125, Hobart FT1019e Dishwashing Machine at Gator Corner

and having familiarized themselves with all conditions affecting and governing the specifications, pricing and delivery of the product and services described herein, hereby proposes to furnish the products and services as per the specifications, in strict compliance with the Bid Documents, Addenda and any other documents relating thereto on file with UF Procurement Services and, if awarded the Contract, agrees to abide by the pricing and delivery terms as per the Documents and as stated herein, for the sums enumerated on this page.

**EQUIPMENT (INCLUDING
18 MONTH WARRANTY): \$** _____

FREIGHT: \$ _____

**LABOR (REMOVAL OF FT900
AND INSTALLATION OF FT1019e): \$** _____

EXTENDED 12 MONTH WARRANTY: \$ _____

TOTAL BID PRICE: \$ _____

Lead Time (Information Only): _____

I have carefully prepared this Bid from contact documents described above, I have full authority to make such statements and submit this Bid in (my) (its) (their) behalf, and all statements are true and correct.

(Signature) (Printed or typed)

(Address, City State, Zip)

(Telephone) (Date)

ATTACHMENT A - GATOR CORNER FLOOR PLAN

