

SUBMIT BID TO:
PROCUREMENT SERVICES
UNIVERSITY OF FLORIDA
971 ELMORE DRIVE
GAINESVILLE, FL 32611

Phone: (352) 392-1331 - FAX: (352) 392-8837
 Web Address: <https://procurement.ufl.edu/>



INVITATION TO BID

Construction Acknowledgment Form

| | | | |
|-------------------------|---------------|--|---|
| Page 1 of 100 pages | | BID WILL BE OPENED: January 27, 2021 at 3:00 PM local time and may not be withdrawn within 90 days after such date and time. Mandatory Pre-bid: January 6, 2021 at 10:00 AM local time. | BID NO.: ITB21KO-127 |
| DATE: 12/16/2020 | | PROCUREMENT AGENT: KO/jh | BID TITLE: Air Handling Unit Replacement at Fine Arts D |
| VENDOR NAME | | | |
| VENDOR MAILING ADDRESS | | REASON FOR NOT SUBMITTING BID | |
| CITY - STATE - ZIP CODE | | <p style="text-align: center;">POSTING OF BID TABULATIONS</p> <p>Bid tabulations with intended award(s) will be posted electronically for review by interested parties at https://procurement.ufl.edu/ and will remain posted for a period of 72 hours excluding Saturdays, Sundays, or state holidays. Failure to file a protest in accordance with Board of Governors (BOG) Regulation 18.002 or failure to post the bond or other security as required in the BOG regulations 18.002 and 18.003(3), shall constitute a waiver of protest proceedings.</p> | |
| AREA CODE | TELEPHONE NO. | | |
| | FAX NO. | | |
| | WEB ADDRESS | | |
| | EMAIL ADDRESS | | |

I certify that this bid is made without prior understanding, agreement, or connection with any corporation, firm or person submitting a bid for the same materials, supplies, or equipment and is in all respects fair and without collusion or fraud. I agree to abide by all conditions of this bid and certify that I am authorized to sign this bid for the vendor and that the vendor is in compliance with all the requirements of the Invitation to Bid, including but not limited to, certification requirements. In submitting a bid on behalf of the Board of Trustees, hereinafter known as the University, the vendor offers and agrees that if the bid is accepted the vendor will convey, sell, assign, or transfer to the University all rights, title and interest in and to all causes of action it may now or hereafter acquire under the Anti-trust laws of the United States and the University for price fixing relating to the particular commodities or services purchased or acquired by the University. At the

University's discretion, such assignment shall be made and become effective at the time the purchasing agency tenders final payment to the vendor.

 AUTHORIZED SIGNATURE (MANUAL)

 NAME AND TITLE (TYPED)

GENERAL CONDITIONS

SEALED BIDS: All bid sheets and this form must be executed and submitted in a sealed envelope. (DO NOT INCLUDE MORE THAN ONE BID PER ENVELOPE.) The face of the envelope shall contain, in addition to the above address, the date, and time of the bid opening and the bid number. Bids not submitted on the attached bid form shall be rejected. All bids are subject to the conditions specified herein. Those which do not comply with these conditions are subject to rejection.

1. **EXECUTION OF BID:** Bid must contain an original manual signature of authorized representative in the space provided above. Bid must be typed or printed in ink. Use of erasable ink is not permitted. All corrections to prices made by vendor must be initialed.

2. **NO BID:** If not submitting a bid, respond by returning only this vendor acknowledgment form, marking it "NO BID", and explain the reason in the space provided above. Failure to respond to a procurement solicitation without giving justifiable reason for such failure, nonconformance to contract conditions, or other pertinent factors deemed reasonable and valid shall be cause for removal of the supplier's name from the bid mailing list. NOTE: To qualify as a respondent, vendor must submit a "NO BID", and it must be received no later than the stated bid opening date and hour.

3. **BID OPENING:** Shall be public, on the date, location and the time specified on the bid form. It is the vendor's responsibility to assure that the bid is delivered at the proper time and place of the bid opening. Bids which for any reason are not so delivered will not be considered. A bid may not be altered after opening of the bids. NOTE: Bid tabulations will be posted electronically at <https://procurement.ufl.edu/>. Bid tabulations will not be provided by telephone.

4. **PRICES, TERMS AND PAYMENT:** Firm prices shall be bid and will include all packing, handling, shipping charges, and delivery to the destination shown herein.

(a) **TAXES:** The University does not pay Federal Excise and Sales taxes on direct purchases of tangible personal property or services. The Florida Tax Exempt Number is 11-06-024056-57C. This exemption does not apply to purchases of tangible personal property or services made by vendors who use the tangible personal property or services in the performance of contracts for the improvement of University-owned real property as defined in Chapter 192, F.S.

(b) **DISCOUNTS:** Vendors are encouraged to reflect trade discounts in the unit prices quoted; however, vendors may offer a discount for prompt payment. Prompt payment discounts will not be considered in the bid award. However, every effort will be made to take the discount within the time offered.

(c) **MISTAKES:** Vendors are expected to examine the specifications, delivery schedule, bid prices, extensions, and all instructions pertaining to supplies and

services. Failure to do so will be at vendor's risk. In case of a mistake in extensions the unit price will govern.

(d) **INVOICING AND PAYMENT:** Payment will be made by the University of Florida after the items awarded to a vendor have been received, inspected, and found to comply with award specifications, free of damage or defect and properly invoiced. All invoices shall bear the purchase order number. Payment for partial shipments shall not be made unless specified. An original invoice shall be submitted. Failure to follow these instructions may result in delay in processing invoices for payment. Payment shall be made in accordance with Section 215.422 (1) (2) F.S. VENDOR OMBUDSMAN: The University's vendor ombudsman, whose duties include acting as an advocate for vendors may be experiencing problems in obtaining payment from the University, may be contacted at 352-392-1241.

(e) **ANNUAL APPROPRIATIONS:** The University's performance and obligation to pay under any contract awarded is contingent upon an annual appropriation by the Legislature.

(f) **CONDITION AND PACKAGING:** It is understood and agreed that any item offered or shipped as a result of this bid shall be a new, current standard production model available at the time of this bid. All containers shall be suitable for storage or shipment, and all prices shall include standard commercial packaging.

(g) **SAFETY STANDARDS:** Unless otherwise stipulated in the bid, all manufactured items and fabricated assemblies shall comply with applicable requirements of Occupational Safety and Health Act and any standards hereunder.

5. **CONFLICT OF INTEREST:** The award hereunder is subject to the provisions of Chapter 112, F.S. All vendors must disclose with their bid the name of any officer, director, or agent who is also an employee of the University of Florida. Further, all vendors must disclose the name of any University employee who owns, directly or indirectly, an interest of five percent (5%) or more in the vendor's firm or any of its branches.

6. **AWARDS:** As the best interest of the University may require, the right is reserved to make award(s) by individual item, group of items, all or none or a combination thereof; to reject any and all bids or waive any minor irregularity or technicality in bids received. When it is determined there is no competition to the lowest responsible vendor, evaluation of other bids are not required. Vendors are cautioned to make no assumptions unless their bid has been evaluated as being responsive.

7. **INTERPRETATIONS/DISPUTES:** Any questions concerning conditions or specifications shall be directed in writing to Procurement Services. Inquiries must reference the date of bid opening and bid number. No interpretations shall be

considered binding unless provided in writing by the University in response to requests in full compliance with this provision.

8. NOTICE OF BID PROTEST BONDING REQUIREMENT: Any person or entity who files an action protesting a decision or an intended decision pertaining to a competitive solicitation shall at the time of filing the formal protest, post with the University a bond payable to the University in an amount equal to: 10% of the estimated value of the protestor's bid or proposal; 10% of the estimated expenditure during the contract term; \$10,000.00; or whichever is less. The bond shall be conditioned upon the payment of all costs which may be adjudged against the person or entity filing the protest action. In lieu of a bond, the University may accept a cashier's check, bank official check or money order in the amount of the bond. FAILURE OF THE PROTESTING PERSON OR ENTITY TO FILE THE REQUIRED BOND, CASHIER'S CHECK, BANK OFFICIAL CHECK OR MONEY ORDER AT THE TIME OF THE FILING THE FORMAL PROTEST SHALL RESULT IN DENIAL OF THE PROTEST.

9. GOVERNMENTAL RESTRICTIONS: In the event any governmental restrictions may be imposed which would necessitate alteration of the material, quality, workmanship or performance of the items offered in this bid prior to their delivery, it shall be the responsibility of the successful vendor to notify the purchaser at once, indicating in writing the specific regulation which requires an alteration. The University reserves the right to accept any such alteration, including any price adjustments occasioned thereby, or to cancel the contract at no expense to the University.

10. LEGAL REQUIREMENTS: Applicable provision of all Federal, State, county and local laws, and of all ordinances, rules and regulations shall govern development, submittal and evaluation of all bids received in response hereto and shall govern any and all claims and disputes which may arise between person(s) submitting a bid response hereto and the University, by and through its officers, employees and authorized representatives, or any other person, natural or otherwise: and lack of knowledge by a vendor shall not constitute a cognizable defense against the legal effect thereof.

11. LOBBYING: Vendor is prohibited from using funds provided under any contract or purchase order for the purpose of lobbying the Legislature or any official, officer, commission, board, authority, council, committee, or department of the executive branch or the judicial branch of state government.

12. ADVERTISING: In submitting a bid, the vendor agrees not to use the results therefrom as a part of any commercial advertising. Vendor may not use the names, logos, or trademarks of the University, its employees, or affiliates without the prior written consent of the University.

13. ASSIGNMENT: Any contract or purchase order issued pursuant to this Invitation to Bid and the monies which may become due hereunder are not assignable except with the prior written approval of the purchaser.

14. LIABILITY: The vendor agrees to indemnify and save the University of Florida, the State of Florida and the Florida Board of Governors, their officers, agents, and employees harmless from any and all judgments, orders, awards, costs and expenses, including attorney's fees, and also all claims on account of damages to property, including loss of use thereof, or bodily injury (including death) which may be hereafter sustained by the vendor, its employees, its subcontractors, or the University of Florida, the State of Florida and the Florida Board of Governors, their officers, agents, or employees, or third persons, arising out of or in connection with any contract awarded and which are the result of the vendor's breach of contract or of the negligent acts of the vendor, its officers, agents, and employees. This clause does not apply to contracts between government agencies.

15. FACILITIES: The University reserves the right to inspect the vendor's facilities at any time with prior notice.

16. ADDITIONAL QUANTITIES: For a period not exceeding ninety (90) days from the date of acceptance of any offer by the University of Florida, the right is reserved to acquire additional quantities up to but not exceeding those shown on bid or the bid level at the prices bid in this invitation. If additional quantities are not acceptable, the bid sheets must be noted "BID IS FOR SPECIFIED QUANTITY ONLY".

17. SERVICE AND WARRANTY: Unless otherwise specified, the vendor shall define any warranty service and replacements that will be provided during and subsequent to this contract. Vendors must explain on an attached sheet to what extent warranty and service facilities are provided.

18. SAMPLES: Samples of items, when called for, must be furnished free of expense, on or before bid opening time and date, and if not destroyed, may upon request, be returned at the vendor's expense. Each individual sample must be labeled with vendor's name, manufacturer's brand name and number, bid number and item reference. Request for return of samples shall be accompanied by instructions which include shipping authorization and name of carrier and must be received with the bid. If instructions are not received within this time, the commodities shall be disposed of by the University.

19. INSPECTION, ACCEPTANCE AND TITLE: Inspection and acceptance will be at destination unless otherwise provided. Title and risk of loss or damage of all items shall be the responsibility of the contract supplier until accepted by the University, unless loss or damage results from negligence by the University. The contract supplier shall be responsible for filing, processing and collecting all damage claims. However, to assist him in the expeditious handling of damage claims, the University will:

(a) Record any evidence of visible damage on all copies of the delivering carrier's Bill of Lading.

- (b) Report damage (Visible or Concealed) to the carrier and contract supplier confirming such reports in writing within 15 days of delivery, requesting that the carrier inspect the damaged merchandise.
- (c) Retain the item and its shipping container, including inner packing material until inspection is performed by the carrier, and disposition given by the contract supplier.
- (d) Provide the contract supplier with a copy of the carrier's Bill of Lading and damage inspection report.

20. PATENTS, COPYRIGHTS, TRADEMARKS, ROYALTIES and other Intellectual Property: The vendor, without exception, shall indemnify and save harmless the University and its employees from liability of any nature or kind, including cost and expenses for or on account of any copyrighted, patented, or unpatented invention, process, or article manufactured or used in the performance of the contract, including its use by the University of Florida. If the vendor uses any design, device, or materials covered by letters, patent or copyright, it is mutually agreed and understood without exception that the bid prices shall include all royalties or costs arising from the use of such design, device, or materials in any way involved in the work.

21. CONFLICT BETWEEN DOCUMENTS: If any terms and conditions contained within the documents that are a part of this ITB or resulting contract are in conflict with any other terms and conditions contained therein, then the various documents comprising this ITB or resulting contract, as applicable, shall govern in the following order of precedence: change order, purchase order, addenda, special conditions, general conditions, specifications, departmental description of work, and bid.

22. MANUFACTURERS' NAMES AND APPROVED EQUIVALENTS: Any manufacturer's names, trade names, brand names, information and/or catalog numbers listed in a specification are for information and not intended to limit competition. If bids are based on equivalent products, indicate on the bid form the manufacturer's name and number. Vendor shall submit with the bid, cuts, sketches, and descriptive literature, and/or complete specifications. Reference to literature submitted with a previous bid will not satisfy this provision. The vendor shall also explain in detail the reasons why the proposed equivalent will meet the specifications and not be considered an exception thereto. The University of Florida reserves the right to determine acceptance of item(s) as an approved equivalent. Bids which do not comply with these requirements are subject to rejection. Bids lacking any written indication of intent to quote an alternate brand will be received and considered in complete compliance with the specifications as listed on the bid form.

23. NONCONFORMANCE TO CONTRACT CONDITIONS: Items may be tested and/or inspected for compliance with specifications by any appropriate testing facilities. Should the items fail, the University may require the vendor to reimburse the University for costs incurred by the University in connection with the examination or testing. The data derived from any tests for compliance with specifications are public records and open to examination thereto in accordance with Chapter 119, F.S. Items delivered not conforming to specifications may be rejected and returned at vendor's expense. These items and items not delivered as per delivery data in bid and/or purchase order may result in vendor being found in default in which event any and all procurement costs may be charged against the defaulting vendor. Any violation of these conditions may also result in the vendor's name being removed from the University of Florida's vendor file.

24. PUBLIC RECORDS: Any material submitted in response to this Invitation to Bid will become a public document pursuant to Section 119.07 F.S. This includes material which the responding vendor might consider to be confidential or a trade secret. Any claim of confidentiality is waived upon submission, effective after opening pursuant to Section 119.07 F.S.

25. DELIVERY: Unless actual date of delivery is specified (or if specified delivery cannot be met), show number of days required to make delivery after receipt of purchase order in space provided. Delivery time may become a basis for making an award (see Special Conditions). Delivery shall be within the normal working hours of the University of Florida, Monday through Friday, unless otherwise specified.

26. PUBLIC PRINTING - PREFERENCE GIVEN PRINTING WITHIN THE STATE: The University of Florida shall give preference to vendors located within the state when awarding contracts to have materials printed, whenever such printing can be done at no greater expense than, and at a level of quality comparable to, that obtainable from a vendor located outside of the state.

(a) **CONTRACTS NOT TO BE SUBLET:** In accordance with Class B Printing Laws and Regulations "Printing shall be awarded only to printing firms. No contract shall be awarded to any broker, agent, or independent contractor offering printing manufactured by other firms or persons."

(b) **DISQUALIFICATION OF VENDOR:** Reasonable grounds for believing that a vendor is involved in more than one bid for the same work will be cause for rejection of all bids in which such vendors are believed to be involved. Any or all bids will be rejected if there is reason to believe that collusion exists between vendors. Bids in which the prices obviously are unbalanced will be subject to rejection.

(c) **TRADE CUSTOMS:** Current trade customs of the printing industry are recognized unless accepted by Special Conditions or Specifications herein.

(d) **COMMUNICATIONS:** It is expected that all materials and proofs will be picked up and delivered by the printer or his representative, unless otherwise specified. Upon request, materials will be forwarded by registered mail.

(e) **RETURN OF MATERIAL:** All copy, photos, artwork, and other materials supplied by the University of Florida must be handled carefully and returned in good condition upon completion of the job. Such return is a condition of the contract and payment will not be made until return is affected.

END OF SECTION

Bid Number: ITB21KO-127

**Title: Air Handling Unit Replacement
at Fine Arts D**

UF Project Number: MP04488



AUTHORIZED REPRESENTATIVES AND CONTACT INFO:

UF PROCUREMENT SERVICES

Karen Olitsky
971 Elmore Drive / PO Box 115250
Gainesville, FL 32611-5250
(352) 294-1163
kolitsk@ufl.edu

NON-TECHNICAL SPECIFICATIONS

TABLE OF CONTENTS

I. Bidding Conditions

00020 Invitation to Bid
00100 Instruction to Bidders
00310 Bid Form
00430 List of Subcontractors

II. General Terms and Conditions

<http://facilities.ufl.edu/forms/contracts/GTC.pdf>

III. Division 0 Non-Technical Specifications

<http://facilities.ufl.edu/forms/contracts/Div0NonTechSpecs.pdf>

IV. Division 1 Non-Technical Specifications

http://facilities.ufl.edu/forms/contracts/Div1_NonTech_Specs_JULY_2017.pdf

V. UF Design and Construction Standards

<https://facilities.ufl.edu/forms/dcs.html>

VI. Standards, Policies, Regulations, Forms, Guides, Inspection & Closeout and References

<http://facilities.ufl.edu/forms.html>

Other Forms

- Dig Permit: <https://www.facilitieservices.ufl.edu/departments/utilities/dig-permits/>
- EH&S Inspection Request Form: <http://www.ehs.ufl.edu/programs/buildcode/>
- State Fire Marshal Inspection Request Form:
http://webfiles.ehs.ufl.edu/sfminsp_reader.pdf

VII. Technical Specifications

Section 01010 – Summary of the Work (1 page)
Division 15 – Mechanical Specifications (49 pages)
Division 16 – Electrical Specifications (28 pages)

VIII. Attachment A

Drawings (10 pages)

00020 - INVITATION TO BID

The Invitation to Bid shall be in accordance with the University of Florida, Procurement Services "Invitation to Bid Acknowledgement Form" with all relevant information provided therein.

END OF SECTION

00020-1

00100 - INSTRUCTIONS TO BIDDERS

1.1 RELATED SECTIONS

- A. Documents affecting the work of this Section include, but are not necessarily limited to, the General Terms & Conditions and other Sections in Divisions 0 and 1 of these Specifications.

1.2 THE WORK

BID NUMBER: ITB21KO-127

PROJECT TITLE: Air Handling Unit Replacement at Fine Arts D

1.3 SECURING DOCUMENTS

Copies of the proposed Contract Documents may be obtained from:

University of Florida Procurement Services website.

<https://procurement.ufl.edu/vendors/schedule-of-bids/>

1.4 BID FORM

In order to be considered responsive and responsible, make bids in strict accordance with the following:

- A. Make bids upon the forms provided, properly signed and with all items completed. Do not change the wording of the bid form and do not otherwise alter or add words to the bid form. Unauthorized conditions, limitations, or provisions attached to the bid may be cause for rejection of the bid.
- B. Include with bid a completed and signed Invitation to Bid Construction Acknowledgment Form.
- C. Include completed Section 00310 - Bid Form.
- D. Include list of subcontractors as described in Section 00430 - Subcontractor Listing.
- E. **Bids must be submitted no later than January 27, 2021 at 3:00PM local time**. No bids received after the time fixed for receiving them will be considered. Late bids will be returned to the bidder unopened.
- F. Address bids to Karen Olitsky, Procurement Agent III, and deliver to:

University of Florida
Procurement Services
971 Elmore Drive / PO Box 115250
Gainesville, FL 32611-5250

Submit bid in a sealed envelope that includes the bid number, contractor name and date and time of the bid opening on the outside of the envelope. Submit one (1) original bid and one (1) electronic copy on flash drive or CD/DVD. It is the sole responsibility of the bidder to see that bids are received on time. Faxed and/or emailed bids will not be accepted.

1.5 PROOF OF COMPETENCY OF BIDDER

A bidder may be required to furnish evidence, satisfactory to the Owner, that the bidder and the bidder's proposed subcontractors have sufficient means and experience in the types of work required to assure completion of the Contract in a satisfactory manner.

1.6 WITHDRAWAL OF BIDS

- A. A bidder may withdraw their bid, either personally or by written request, at any time prior to the scheduled time for opening bids.
- B. No bidder may withdraw their bid for a period of ninety calendar days after the date set for opening thereof, and bids shall be subject to acceptance by the Owner during this period.

1.7 QUALIFICATION OF BIDDERS

- A. A contract will be awarded only to a responsible bidder, qualified by experience and in a financial position to perform the work specified.
- B. If the bidder has not been pre-qualified with UF Procurement Services within the fiscal year (July 1 through June 30), the bidder may be required to submit the following evidence of eligibility:
 - 1. Evidence that bidder is licensed by the appropriate government agency to perform the work specified.
 - 2. Experience record showing bidder's training and experience in similar work.
 - 3. List a brief description of projects of similar size and/or complexity satisfactorily completed, with location, dates of contracts, names of contracts, and names and addresses of owners.

1.8 SUBCONTRACTS

If the Bidder intends to subcontract any of the Work:

- A. A list of all proposed subcontractors shall be provided with the bid for scopes/packages in excess of \$10,000. See Section 00430 - Subcontractor Listing.
- B. Each subcontractor performing work in excess of \$10,000 must present evidence of being qualified in and licensed for the applicable trade. Such proof of subcontractor licensure shall be provided by the successful bidder after award, but prior to commencement of Work.

1.9 PERFORMANCE AND PAYMENT BONDS

See General Terms & Conditions, Article 20.

1.10 BID DEPOSIT

Not required.

1.11 AWARD OR REJECTION OF BIDS

The Contract, if awarded, will be awarded to the responsible and responsive bidder who has proposed the lowest Contract Sum, subject to the owner's right to reject any or all bids and to waive informality

and irregularity in the bids and in the bidding.

1.12 MANDATORY PRE-BID CONFERENCE:

A mandatory Pre-bid Conference will be held prior to the scheduled bid opening for the purpose of considering questions posed by bidders. The conference will be open to interested bidders, prospective subcontractors, and any other interested parties. This conference will be held **January 6, 2021 at 10:00 AM local time. Meeting will begin outside the front entrance of Fine Arts D, Building 0269, 1357 Stadium Road, Gainesville, FL.**

1.13 EXECUTION OF AGREEMENT

- A. A Purchase Order (PO) will be issued for purposes of fiscal encumbrance and payment. The PO itself serves as the form of contract.
- B. Upon notice of Bid Award, the bidder to whom the Contract is awarded shall deliver to UF those Certificates of Insurance and Payment & Performance Bonds required by the Contract Documents.
- C. Bonds and Certificates of Insurance shall be approved by UF before the successful bidder may proceed with the Work.

1.14 INTERPRETATION OF CONTRACT DOCUMENTS PRIOR TO BIDDING

- A. If any person contemplating submitting a bid for construction of the Work is in doubt as to the true meaning of any part of the Contract Documents, or finds discrepancies in or omissions from any part of the Contract Documents, they may submit a written request for interpretation thereof no later than **January 12, 2021 at 5:00 PM** local time, to Karen Olitsky, Procurement Agent III at kolitsk@ufl.edu. The person submitting the request shall be responsible for its prompt delivery.
- B. Interpretations or corrections of proposed Contract Documents will be made only by Addendum and will be available on the Procurement Services "Schedule of Bids" webpage <https://procurement.ufl.edu/vendors/schedule-of-bids/>. The Owner will not be responsible for any other explanations or interpretations of the proposed Contract Documents.

1.15 TIME OF COMPLETION:

- A. Date of beginning, rate of progress and time for completion of Work for this Project are ESSENTIAL CONDITIONS of Contract. Successful Bidder hereby agrees that Work required by this Contract shall be commenced within ten (10) calendar days after issuance date of written Notice to Proceed; that all insurance and permits will be obtained; that all documents and notices will be filed; that all requirements as specified will be met; and that Work shall be prosecuted regularly, diligently and uninterruptedly at such rate of progress as will insure Substantial Completion of entire Project within 150 calendar days after receipt of Notice to Proceed, and shall be finally completed within 15 days after the date of Substantial Completion.

END OF SECTION

00100-3

00310 - BID FORMS

BID PROPOSAL

FROM: _____
(Name of Bidder)

TO: UNIVERSITY OF FLORIDA
PROCUREMENT SERVICES
971 Elmore Drive
P.O. Box 115250
Gainesville, Florida 32611-5250

The undersigned, hereinafter called "Bidder", having reviewed the Contract Documents for the Project entitled **ITB21KO-127 Air Handling Unit Replacement at Fine Arts D** and having visited and thoroughly inspected the site of the proposed Project and familiarized himself/herself with all conditions affecting and governing the construction of said Project, hereby proposes to furnish all labor, materials, equipment and other items, facilities and services for the proper execution and completion of the Project, in strict compliance with the Contract Documents, Addenda, and all other Documents relating thereto on file in Procurement Services, and, if awarded the Contract, to complete the said Work within the time limits called for in the Documents and as stated herein, for the sums as enumerated on this and the following pages:

BASE BID:

_____ Dollars

Figures: \$ _____

ADDENDA:

Receipt of the following Addenda to the Construction Documents is acknowledged:

ADDENDUM # _____ Dated _____

ADDENDUM # _____ Dated _____

ADDENDUM # _____ Dated _____

COMPLETION DATE:

All Work covered by the Bidding Documents and the foregoing Base Bid shall be completed and ready for Owner's occupancy as specified in the contract documents.

SIGNATURE:

I hereby certify that for all statements and amounts herein made on behalf of

(Name of Bidder)

a (Corporation) (Partnership) (Individual) organized and existing under the laws of the State of Florida, I have carefully prepared this Bid Proposal from Contract Documents described hereinbefore, I have examined Contract Documents and local conditions affecting execution of Work before submitting this Bid Proposal, I have full authority to make the statements and commitment herein and submit this Bid Proposal in (its) (their) behalf, and all statements are true and correct.

Signed and sealed this _____ day of _____, 2020.

(Signature of Bidder)

(Print Name)

(Title)

WITNESS:

(Signature of Witness)

(Print Name)

Address: _____

(City) (State) (Zip Code)

END OF SECTION

00430 - SUBCONTRACTOR LISTING

1.1 RELATED SECTIONS

- A. Documents affecting the work of this Section include, but are not necessarily limited to, the General Terms & Conditions and other Sections in Divisions 0 and 1 of these Specifications.

1.2 SUBCONTRACTOR LISTS

- A. Each bidder shall furnish with its bid a list of all subcontractors for subcontracted scopes/packages of work valued at more than \$10,000.
- B. This list shall identify – for each subcontracted package in excess of \$10,000 – the name and address of the proposed subcontractor and the approximate value of the subcontract.
- C. If the bidder does not intend to subcontract portions of the Work in amounts greater than \$10,000, then a statement to that effect shall be furnished with the bid.
- D. See Section 00100 - Instruction to Bidders regarding subcontractor licensure requirements.

END OF SECTION

SECTION 01010 - SUMMARY OF THE WORK

PART 1 - GENERAL

1.1 RELATED SECTIONS:

Documents affecting the work of this Section include, but are not necessarily limited to, the General Conditions, the Supplementary Conditions, and other Sections in Division 1 of these Specifications.

1.2 DESCRIPTION OF WORK INCLUDED:

The work includes:

1. T&B contractor shall perform preconstruction testing of all air handling units (AHU-1, AHU-4 and AHU-5), chilled water pump and exhaust fans (EF-12, 16, 17, 18, 19, 20 and 21). In addition, supply, return and exhaust air devices air quantities.
2. Demolition of existing AHU-1 chilled water unit including piping, ductwork, zone electric heating coils and mechanical controls.
3. Installation of new AHU-1 chilled water air handling unit, piping, zone electric heating coils, controls and ductwork to provide a complete and operating air handling system.
4. Electrical power in support of AHU-1 replacement.
5. Modifications and reuse of existing J.C.I. mechanical control system serving AHU-1, AHU-4 and AHU-5 including associated interlocked exhaust systems.
6. Modifications to existing building Fire Alarm System in support of AHU-1 replacement.
7. Demolition and replacement of P-1 chilled water pump including VSD.
8. Modification and upgrade of Johnson control system graphics.
9. Roofing modifications to support installation of AHU-1 roof mounted outside air intake.
10. Final testing, adjusting and balancing of all building equipment and air distribution systems. In addition, provide commissioning report.

END OF SECTION

DIVISION 15 / MECHANICAL - TABLE OF CONTENTS

| Section No. | Description |
|--------------------|---|
| 15000 | Mechanical, General |
| 15004 | General Materials and Execution for Piping System |
| 15139 | Mechanical Identification |
| 15142 | End Suction Circulating Water Pumps |
| 15154 | Air Handling Units |
| 15170 | Roof Mounted Outside Air Intakes and Relief Vents |
| 15181 | Vibration Isolation |
| 15211a..... | Sheetmetal Ductwork and Accessories |
| 15216a | Exterior Insulation of Air Distribution Items |
| 15235 | Electric Unit Mounted Heating Coil |
| 15262d | Variable Frequency Drives |
| 15302 | Black Steel Piping |
| 15312 | Copper Drainage Piping |
| 15323 | Gauges, Thermometers and Thermometer Wells |
| 15325 | Insulation for Equipment and Piping (All Systems) |
| 15328 | Valves Not Part of Control Systems |
| 15342 | HVAC Chilled Water System |
| 15349 | Piping Systems Pressure Testing, Cleaning and Sterilization |
| 15407 | Testing and Balancing of Mechanical Systems |

SECTION 15000 - MECHANICAL, GENERAL

PART 1 - GENERAL

1.01 CONTRACT PROVISIONS:

- A. Division 1, General Requirements Specifications.
- B. Work, materials and equipment specified in this Section of the Specifications apply to all work in Division 15.
- C. Division 0, Bidding and Contract Requirements.
- D. Contractor shall arrange for all permits and inspections required. No fees will be charged to the Contractor for permitting and inspections.

1.02 FIELD MEASUREMENTS AND COORDINATION:

- A. Verify all field dimensions and locations of equipment, to insure close, neat fit, with other trades' work.
- B. Coordinate work in this Division with all other trades in proper sequence to insure that the total work is completed within contract time schedule.
- C. Locate all apparatus symmetrical with architectural elements. In other instances, locations will be shown on mechanical drawings in certain positions; then be guided by conditions existing at job, correlating this work with that of others.
- D. Install work as required to fit structure, avoid obstructions, and retain clearance, headroom, openings and passageways. Cut no structural members without written approval.
- E. Carefully examine any existing conditions, piping and premises, and compare drawings with existing conditions. Report any observed discrepancies. Written instructions will be issued to resolve discrepancies.

1.03 RELATED WORK IN OTHER DIVISIONS:

- A. Division 16 - Disconnect switches, starters, contactors, manual switches, pilot lights, wiring and conduit not indicated in Division 15 shall be furnished as part of the work under Division 16.

1.04 CONNECTING TO WORK OF OTHERS:

- A. Prior to starting and during progress of work, examine work and materials installed by others insofar as they apply to work in this division. Report conditions which will prevent satisfactory installation.
- B. Start of work will be construed as acceptance of suitability of work of others.

1.05 SINGULAR REFERENCES:

- A. Singular references in this Division's specification sections shall not be construed as requiring only one device if multiple devices are shown on drawings.

1.06 CONTRACT DRAWINGS:

- A. For purposes of clearness and legibility, drawings are essentially diagrammatic. Although size and location of equipment are drawn to scale wherever possible, make use of all contract documents and shop drawings to verify exact sizes, dimensions and locations.

- B. Drawings indicate locations of fixtures and equipment and convey general intent of work. They are not intended to show minute details of all components.
- C. Drawings and specifications are supplementary one to another. An attempt has been made on the drawings to separate and apportion work of the trades. However, such separation and apportionment does not relieve Contractor from full responsibility of compliance. Drawings and specifications intend one complete workable system correctly installed, ready for service, with all materials and work indicated.
- D. Conflicts between drawings and specifications shall be reported prior to bidding. Written clarification will be promptly issued to contractor.

1.07 REQUEST FOR SUBSTITUTIONS:

- A. Contractors shall submit all requests for approval of alternate manufacturer's products to Karen Olitsky, Procurement Agent III, at kolitsk@ufl.edu no later than 1/12/2021 at 5PM. Requests will not be considered unless submitted by a Contractor in written form on his letterhead. Approval will be in form of addendum to specifications. Clearly and specifically indicate any and all differences between product specified and product proposed. Differences include, but are not limited to, the following data for both specified and substituted products:
 - 1. Principle of operation.
 - 2. Materials of construction or finishes.
 - 3. Thickness or gauge of material.
 - 4. Weight of item.
 - 5. Deleted features or items.
 - 6. Added features or items.
 - 7. Changes in other trades caused by the substitution.
 - 8. Electrical characteristics, MCA, MOCP, etc.
- B. If Approved Substitution Contains Differences Not Indicated in Request, the Right Is Reserved to Require Equal or Similar Features to Be Added to the Substituted Products, at No Additional Cost.
- C. Refer to Section 01340 - Submittals and Substitutions for additional requirements.

1.08 MODEL NUMBERS:

- A. Catalog Numbers and Model Numbers Indicated in the Drawings and Specifications Are Used as a Guide in the Selection of the Equipment and Are Only Listed for the Contractors Convenience. The Contractor Shall Determine the Actual Numbers for Ordering Materials in Accordance with the Written Description of Each Item and with the Intent of the Drawings and Specifications.

1.09 CONSTRUCTION UTILITIES:

- A. Owner will pay for all utilities used for construction. See Section 01500 for additional requirements.

1.10 MATERIAL STORAGE AND PROTECTION:

- A. Contractor shall store and protect all material and equipment to prevent damage and weathering.

1.11 INSTRUCTIONS:

- A. At completion of the work, provide a competent and experienced person who is thoroughly familiar with project, for a period of two (2) working day(s) to instruct permanent operating personnel in operation of equipment and control systems.
- B. Furnish four complete sets of operating and maintenance instruction as well as parts list applying to each piece of equipment installed in conjunction with this contract, in accordance with the provisions

of Section 01700. In addition, provide operating and maintenance instructions including parts lists on electronic media. Frame under glass "As Installed" diagram of controls and wiring, and mount on equipment room wall in location directed.

1.12 "AS-BUILT" RECORD DRAWINGS:

- A. At the commencement of the work the Contractor will be furnished two (2) complete sets of white prints of the mechanical and plumbing drawings. All corrections, variations and deviations to the drawings, including those required by change orders, if any, must be recorded in colored ink or colored pencil at the end of each working day on these prints which shall be available at all times for inspection.
- B. The Contractor shall submit one (1) complete set of these white prints, marked as stated above, indicating the actual completed installation of the work included under this Division.

1.13 ACCEPTANCE:

- A. Submit written confirmation that all punch lists issued during construction have been checked and the required work completed.
- B. Submit six (6) certified copies of the Test and Balance report.
- C. Submit a letter from an authorized representative of the air conditioning equipment manufacturer stating that all units have been checked and that the system is operating as intended.
- D. Submit "As-Builts" of the work under this Division prepared as required in 1.12 above.
- E. Refer to Section 01700 - Contract Closeout for additional requirements.
- F. Permanently tag valves with coded brass discs attached with brass chain. Coordinate code with operating instructions. Rivet engraved plastic identification nameplates to electric switches and controls. See Section 15004, Paragraph 2.05, for valve tags.
- G. Bind maintenance instructions and parts lists in booklets, and electronic media prior to Substantial Completion.
- H. Acceptance will be made on basis of tests and observations of job. A representative of firm that performed test and balance work shall be in attendance to assist. Contractor shall furnish necessary mechanics to operate system, make any necessary adjustments and assist with final inspection.
- I. Submit schedule for equipment maintenance during guarantee period.
- J. Submit Certificate of Completion or Certificate of Occupancy issued by Building Code Administrator (EH&S).

1.14 CLEANUP:

- A. Thoroughly clean all exposed parts of apparatus and equipment of cement, plaster, and other materials and remove all oil and grease spots. Repaint or touch up as required to look like new. Such surfaces to be carefully wiped and all cracks and corners scraped out. Exposed metal to be carefully brushed down with steel brushes to remove rust and other spots and touch up with primer. During progress of work, Contractor shall clean up and leave premises and all portions of building free from debris and in a clean and safe condition. Brush out fins on all cooling and heating coils.

1.15 GUARANTEE AND SERVICE:

- A. The Contractor shall guarantee labor, materials and equipment for a period of one (1) year from Substantial Completion, or from Owner's occupancy, whichever is earlier and shall include all necessary adjustments to and replacement of defective items.
- B. Owner reserves right to make emergency repairs as required to keep equipment in operation without voiding Contractor's Guarantee Bond nor relieving Contractor of his responsibilities during guarantee period.
- C. In addition to the guarantee, contractor shall furnish maintenance for all new equipment during the guarantee period. Contractor shall submit an itemized list of work to be performed during scheduled maintenance visits and dates visits will be made.

1.16 SYSTEM OPERATION:

- A. Contractor shall operate cooling and heating systems as required after initial startup for testing, adjusting and balancing. The contractor's one year warranty on equipment shall not begin until the date of substantial completion.

1.17 WORKMANSHIP:

- A. Installation of equipment, fixtures and materials shall be made by competent specialists in each trade. The work shall be done in an orderly manner allowing adequate space for servicing valves and equipment. Slipshod or untidy installation of equipment, fixtures or materials will not be accepted. It is the contractor's responsibility to supervise the work with sufficient care to prevent unacceptable workmanship from occurring.

1.18 SUBMITTALS:

- A. Submittals shall be made in accordance with the General Conditions and Supplementary General Conditions of the Project Manual. Submittals shall include references to specification section number.
- B. Shop drawings, material lists, cuts and other data required for review shall be submitted for each Section of Division 15 that indicates submittals are required. Submittals shall be by section in a single group.
- C. If any required items are omitted from this submittal, the Owner's representative shall select each item indicating producer, model, etc., and such decision shall be final.
- D. Refer to Section 01340 - Submittal and Submittals and Substitutions for additional requirements.

1.19 ASBESTOS:

- A. No product, material or process containing Asbestos shall be permitted in this Division's work.
- B. See Section 00903 for additional requirements.

1.20 HAZARDOUS WASTE:

- A. The dispersal, discharge, escape, release or saturation of smoke, vapors, soot, fumes, acids, alkalis, toxic chemicals, liquids, gases, or pollutant in or into the atmosphere, or on, onto, upon, in or into the surface or subsurface soil, water, objects are not permitted by this Division's work.

1.21 LEAD:

MP04488 UF Fine Arts "A" Building No. 0269 Replace AHU-1

- A. Pipe, solder, flux or equipment which is used in the installation of providing water for human consumption shall be lead free.

END OF SECTION

SECTION 15004 - GENERAL MATERIALS AND EXECUTION FOR PIPING SYSTEMS

PART 1 - GENERAL

1.01 This Section Applies to All Piping Work in Division 15.

1.02 ACCEPTABLE PRODUCERS:

A. Named hereinafter, substitutions may be submitted in accordance with Section 15000.

1.03 SUBMITTALS:

A. Catalog data required for all items indicated that will be used on this project.

PART 2 - PRODUCTS

2.01 HANGERS:

A. Clevis Type: Underwriter's and Factory Mutual approved adjustable wrought clevis hanger, Grinnell Fig. 260. Use copper plated adjustable wrought clevis hanger on copper lines, Grinnell Fig. CT-65.

B. Clevis Roller Hanger: Grinnell Fig. 181.

C. Trapeze Type: Construct of engineered channel as manufactured by Kindorf Division of Midland-Ross Corp., with C-105 rigid pipe straps minimum requirements as follows:

1. 3" and Smaller Lines: B-901 channel with 3/8" hanger rods, maximum of 4 lines on 36" maximum span.

2. 4" and 6" Lines: B-902 channel with 1/2" hanger rods, maximum of 4 lines on 48" maximum span.

3. 8" and 10" Lines: B-902 channel with 1/2" hanger rods, maximum of 2 lines on 30" maximum span, 4 lines on 60" maximum span with center rod.

4. 12" and Larger Lines: As indicated.

D. Riser Clamps: Black carbon steel two-bolt pipe riser clamp, Grinnell Fig. 261. Use copper plated clamp, Grinnell Fig. CT-121 for un-insulated copper lines.

E. Rod Inserts: Black malleable iron universal concrete insert, Grinnell CB, Fig. 282. In area of the work where above type inserts were not installed, use Phillips Drill Co. "Red-Head" self-drilling rod inserts.

F. U-Bolt: Grinnell Fig. 137.

G. Welded Steel Wall Brackets: Grinnell Fig. 195 or 199.

H. Pipe Guides: Grinnell Fig. 256.

I. Adjustable Steel Pipe Stanchion: Grinnell Fig. 259.

2.02 SLEEVES:

A. In non-fire rated walls use 22 gauge galvanized steel sheet for masonry and 18 gauge galvanized steel sheet with watertight seams and joints for concrete.

- B. In fire rated walls, floors and roofs use Pipe Shields Inc., Model WFB or DFB for un-insulated piping. Use Model WFB-CS or DFB-CS for insulated piping.

2.03 ESCUTCHEONS:

- A. One piece chrome plated cast brass.

2.04 PACKING MATERIALS:

- A. 4 PCF inorganic high temperature insulating blanket. Manville Thermo-Mat.

2.05 PIPING IDENTIFICATION:

- A. Pressure sensitive vinyl pipe markers conforming to ANSI A13.1-1981 indicating direction of flow and contents. Size of letters shall be: 1/2" for pipe up to 1-1/4", 3/4" for pipe 1-1/2"-2", 1-1/4" for pipe 2-1/2"-6" and 2-1/2" for pipe 8" and larger. Valve tags shall be 1-1/2" diameter solid brass with 1/2" high black filled numbers.

2.06 PAINTING SCHEDULE:

| | |
|--|---------------|
| Hangers and Supports | Black Enamel |
| Domestic Water Piping | Green Enamel |
| Refrigerant Piping | Orange Enamel |
| Gas Piping | Yellow Enamel |
| Fire Protection Piping | Red Enamel |
| Do Not Paint Insulated or Jacketed Surfaces. | |

2.07 ACOUSTICAL TILE ACCESS PANEL MARKERS:

- A. Provide metal tack style with 7/16" long point and _" diameter head, Seton BCM or equal. Provide color code as follows:

| | |
|-----------------------------|-------------|
| Plumbing Valves | Yellow |
| Mechanical Piping Valves | Light Green |
| Fire Dampers | Red |
| Mechanical Fans & VAV Boxes | Light Blue |

2.08 METAL ACCESS PANEL MARKERS:

- A. Provide color coding self-adhesive labels - 3/4" round - Avery Ave. 5400 Series or equal. Provide color code as follows:

| | |
|--------------------------|-------------|
| Plumbing Valves | Yellow |
| Mechanical Piping Valves | Light Green |
| | |

| | |
|-----------------------------|------------|
| Fire Dampers | Red |
| Mechanical Fans & VAV Boxes | Light Blue |

PART 3 - EXECUTION

3.01 Run Piping Straight and Plumb. Grade in direction indicated. Squarely cut pipe and properly ream to remove all burrs before making up joints. Paint exposed threads to retard rusting. Aluminum paint on galvanized pipe and black paint on normally unpainted black steel pipe. Additional requirements are contained in specific pipe sections.

3.02 VERTICAL PIPE SUPPORT SPACING:

- A. Cast iron pipe shall be supported at the base and at every story level at intervals not exceeding 15 feet.
- B. Steel pipe shall be supported at the base and at every story level at intervals not exceeding 30 feet.
- C. Copper tube shall be supported at each story for piping 1-½" or larger and at 4 foot intervals for piping 1-¼" and smaller.
- D. Plastic pipe shall be supported at each story for piping 2" or larger and at 4 foot intervals for piping 1-½" or smaller.
- E. Glass piping shall be supported at every story level.

3.03 HORIZONTAL PIPE SUPPORT SPACING:

- A. Cast iron pipe shall be supported at 5 foot intervals for 5 foot length and 10 foot intervals for 10 foot lengths. Hangers shall be located as close to joints as possible.
- B. Steel pipe shall be supported at 6 foot intervals for piping 2" or smaller at 12 foot intervals for piping 2-½" or larger.
- C. Copper tubing shall be supported at 6 foot intervals for piping 1-½" or smaller and 10 foot intervals for piping 2" or larger.
- D. Plastic pipe shall be supported at 4 foot intervals.
- E. Glass piping shall be supported in strict compliance with the producers printed instructions.

3.04 Install Pipe Guides on each side of expansion joint or loop within building. Locate guides no further than 3 pipe diameters on each side of joint or loop.

3.05 Roller Pipe Supports shall be used for pipe subject to axial movement and shall be braced so that movement occurs in roller and not support rods.

3.06 Install Escutcheons on all piping at each penetration of a finished surface. Escutcheon shall cover projecting sleeve and fit tight to surface penetrated.

3.07 Install Pipe Sleeves at all penetrations of walls and floors above and below grade. Pipe sleeves shall project one inch on each side of surface penetrated. Pack space between sleeve and pipe with specified materials. Install escutcheons where penetrations are exposed.

3.08 Install Insulating Union Fitting (dielectric) at all junctions of copper pipe and steel equipment or piping. Use Victaulic Clear-flow dielectric nipples, dielectric flange kits or CTS dielectric flange kit.

Where possible, locate union so it can be isolated with valves and removed from system with minimum drainage of piping.

- 3.09 Place Rod Inserts in concretes forms prior to time concrete is poured. If additional inserts are required after concrete is poured, use self-drilling rod inserts.
- 3.10 Identify above Grade Piping at intervals of 10 feet.
- 3.11 Install Pipe Unions at locations in piping to permit servicing of devices and equipment.
- 3.12 ACOUSTICAL TILE IDENTIFICATION:
- A. Place color coded metal tack or tacks on exposed side of ceiling tile to identify the access point for items located above ceiling in accordance with product color codes. Locate tack or tacks in the least conspicuous corner of the ceiling tile.
- 3.13 METAL ACCESS PANEL IDENTIFICATION:
- A. After panel has received final coat of paint, place self adhesive label or labels on the exposed side of panel. Label or labels to be in accordance with product color codes. Place labels in the least conspicuous corner but avoid access panel cam lock screws and hinges. After installation light aerosol spray labels with clear polyurethane to seal labels from moisture. Secure with adhesive on rough surfaces.
- 3.14 ELECTRICAL EQUIPMENT SPACES:
- A. Do not route piping through electrical equipment spaces.
- 3.15 IDENTIFICATION OF UNDERGROUND UTILITIES AND PIPING:
- A. Warning Tape: All underground piping and utilities shall have metalized warning tape installed above the pipe or line that identifies the specific system buried below. Tape shall consist of a minimum 3.5 mil solid foil core encased in a protective plastic jacket (total thickness 5.5 miles) and be 6" wide with black lettering imprinted on a color coded background tat conforms to APWA color code specifications. Tape shall be installed from 18" to 30" above the pipe and in no case less than 6" below grade.
- B. Tracer Wire: All non-metallic pipe installed underground (except pipe containing electrical lines) shall have a tracer wire installed along the length of the pipe. The wire shall be taped to the pipe and not allowed to "float freely" within the backfill. Tracer wire shall be 14-1-UF gauge minimum, copper single-conductor wire with type UF (Underground Feeder) insulation and shall be continuous along the pipeline passing through the inside of each valve box.

END OF SECTION

SECTION 15139 - MECHANICAL IDENTIFICATION

PART 1 - GENERAL

1.01 RELATED SECTIONS:

- A. See Section 15000 for related work in other Divisions and Sections
- B. Division 1 specification sections apply to work of this section.
- C. Refer to other Division 15 sections for items to be identified according to this section.
- D. Refer to Division 16 for electrical identification.

1.02 SCOPE OF SECTION:

- A. This section contains the requirements relating to the materials and methods used to identify items described in Division 15.

1.03 CODES AND STANDARDS:

- A. Comply with ANSI A13.1 for lettering size, length of color field, colors, and viewing angles of identification devices.

PART 2 - PRODUCTS

2.01 PAINTED IDENTIFICATION MATERIALS:

- A. Stencils: Standard fiberboard stencils, prepared for required applications with letter sizes generally complying with recommendations of ANSI A13.1 for piping and similar applications but not less than 1-¹/₄" high letters for ductwork and not less than ³/₄" high letters for access door signs and similar operational instructions.
- B. Stencil Paint: Standard exterior type stenciling enamel; black, except as otherwise indicated; either brushing grade or pressurized spray-can form and grade.
- C. Identification Paint: Standard identification enamel.

2.02 PLASTIC PIPE MARKERS:

- A. Pressure Sensitive Type: Provide manufacturer's standard pre-printed permanent adhesive, color-coded, pressure sensitive vinyl pipe markers.
 - 1. Lettering: Manufacturer's standard pre-printed nomenclature which best describes piping system in each instance, as selected by Architect / Engineer in cases of variance with name as shown or specified.
 - 2. Arrows: Print each pipe marker with arrows indicating direction of flow; either integrally with piping system service lettering (to accommodate both directions), or as separate unit of plastic.

2.03 PLASTIC TAPE:

- A. General: Provide manufacturer's standard color-coded pressure sensitive (self-adhesive) vinyl tape, not less than 3 mils thick.
- B. Width: Provide 1-¹/₂" wide tape markers on pipes with outside diameters (including insulation, if any) of less than 6". 2-¹/₂" wide tape for larger pipes.

2.04 VALVE TAGS:

- A. Brass Valve Tags: Provide 19-gauge polished brass valve tags with stamp engraved piping system abbreviation in ¼" high letters and sequenced valve numbers ½" high and with 5/32" hole for fastener. Provide 1-½" diameter tags except as otherwise indicated.
- B. Plastic Laminate Valve Tags: Provide manufacturer's standard 3/32" thick engraved plastic laminate valve tags, with piping system abbreviation in ¼" high letters and sequenced valve numbers ½" high, and with 5/32" hole for fastener. Provide 1-½" square black tags with white lettering, except as otherwise indicated.

2.05 ENGRAVED PLASTIC LAMINATE SIGNS:

- A. General: Provide engraving stock melamine plastic laminate, in the sizes and thickness indicated, engraved with engraver's standard letter style of the sizes and wording indicated, punched for mechanical fastening except where adhesive mounting is necessary because of substrate.
- B. Thickness: 1/16" for units up to 20 square inches or 8" length; _" for larger units.
- C. Fasteners: Self-tapping stainless steel screws, except contact-type permanent adhesive where screws cannot or should not penetrate the substrate.

PART 3 - EXECUTION

3.01 INSTALLATION REQUIREMENTS:

- A. Coordination: Where identification is to be applied to surfaces which require insulation, painting or other covering or finish, including valve tags in finished mechanical spaces, installation of identification after completion of covering and painting. Identification is to be installed prior to installation of acoustical ceilings and similar removable concealment.
- B. Ductwork Identification:
 - 1. General: Provide for identification of air supply, return, exhaust, intake, and relief ductwork with stenciled signs and arrows, showing ductwork service and direction of flow, in black and white.
 - 2. Locations: In each space where ductwork is exposed, or concealed only by removable ceiling system, provide for signs near points where ductwork originates or continues into concealed enclosures, and at 50' spacings along exposed runs.
 - 3. Access Doors: Provide stenciled signs on each access door in ductwork and housings, indicating purpose of access (to what equipment) and other maintenance and operating instructions, and appropriate and procedural information.
- C. Piping System Identification:
 - 1. General: Provide for pipe markers of one of the following types on each system indicated to receive identification, and include arrows to show normal direction of flow:
 - a) Plastic pipe markers with application system as indicated under "Materials" in this section. Install on pipe insulation segment where required for hot non-insulated pipes.
 - b) Stenciled markers, black or white for best contrast, wherever continuous color coded painting of piping is provided.

2. Locate pipe markers and color bands as follows wherever piping is exposed to view in occupied spaces, machine rooms, accessible maintenance spaces and exterior non-concealed locations.
 - a) Near each valve and control device.
 - b) Near each branch, excluding short take-offs for fixtures and terminal units; mark each pipe at branch, where there could be question of flow pattern.
 - c) Near locations where pipes pass through walls, floors, ceilings, or enter non-accessible enclosures.
 - d) At access doors, manholes and similar access points which permit view of concealed piping.
 - e) Near major equipment items and other points of origination and termination.
 - f) spaced intermediately at maximum spacing of 50' along each piping run, except reduce spacing to 25' in congested areas of piping and equipment.
 - g) On piping above removable acoustical ceilings, except omit intermediately spaced markers.
3. The following piping shall be color coded (not banded or striped) in exposed locations by completely painting the piping with the indicated color. Use standard identification methods in concealed areas.
 - a) Fire Protection Piping - RED.
 - b) Gas Piping - YELLOW.
- D. Valve Identification: Provided for valve tags on every valve cock and control device in each piping system; exclude check valves, valves within factory fabricated equipment units, plumbing fixture faucets, convenience and lawn-watering hose bibs, and shut-off valves at plumbing fixtures. HVAC terminal devices and similar rough-in connections of end-use fixtures and units.
- E. Mechanical Equipment Identification: Provide for engraved plastic laminate sign on or near each major item of mechanical equipment and each operational device. Provide signs for the following general categories or equipment and operational devices:
 1. Main control and operating valves, including safety devices.
 2. Meters, gauges, thermometers and similar units.
 3. Fuel burning units including boilers, furnaces, and heaters.
 4. Pumps, compressors, chillers, condensers and similar motor driven units.
 5. Heat exchangers, coils, evaporators, cooling towers, heat recovery units and similar equipment.
 6. Fans, blowers, primary balancing dampers and VAV boxes.
 7. HVAC central station and zone type units.
 8. Tanks and pressure vessels.
 9. Air conditioning indoor and outdoor units.

10. AFD's and transmitters and Control Boxes.

F. Field Control Devices: Provide for small (2" x ¾") engraved plastic laminate tags, white and black letters, for all field controlled devices.

1. Tag shall be engraved with the name of the device as described in the EMCS software. For example "211-TMP" for the temperature element in Room 211.
2. For exposed devices, tag shall be located on or near the device.
3. For concealed devices, tag shall be affixed in an exposed location to allow UF personnel to determine the location of the device without removing the concealing material. If several small devices are located on one concealed unit, only the main unit need be identified with an exposed tag.
4. The following devices shall be so labeled:

| | |
|---|--------------------|
| Temperature Elements | XXX-TMP |
| VAV Boxes | XXX-VAV |
| VAV Controllers (if remote from box) | XXX-VAV Cont. |
| Static Pressure Transmitters | AHU-XX SP |
| Discharge Air Temp Transmitters | AHU-XX Zone ZZ DAT |
| Any other Field Mounted Control Devices | |

3.02 STAMPED NAMEPLATES:

- A. Equipment manufacturers to provide standard stamped nameplates on all major equipment items such as motors, pumps, AHU's etc. Where motors are hidden from view (within equipment casing, or otherwise not easily accessible, etc), the equipment supplier shall furnish a duplicate motor data nameplate to be affixed to the equipment casing in an easily visible location, unless data is already included on the equipment nameplate.

3.03 ADJUSTING AND CLEANING:

- A. Adjusting: Relocate any mechanical identification device which has become visually blocked by work of this division or other divisions.
- B. Cleaning: Clean face of identification devices, and glass frames of valve charts.

END OF SECTION

SECTION 15142 – END SECTION CIRCULATING WATER PUMPS

PART 1 - GENERAL

- 1.01 See Sections 15000 for related work in other Sections and Divisions.
- 1.02 ACCEPTABLE PRODUCERS:
- A. This specification refers to products produced by Aurora and Bell and Gossett. Products produced by other nationally recognized producers may be submitted to Engineer for approval, in accordance with Division 1 and Section 15000. Pumps listed in this section shall be the product of one manufacturer.
- 1.03 SUBMITTALS:
- A. Shop drawings, including all pertinent dimensions.
 - B. Certified rating data, including pump curves. Curves for variable speed pumps shall indicate GPM, BHP, head and efficiency at speeds from 10% to 100% in 10% increments.
 - C. Electric motor characteristics.
 - D. Installation instructions.
 - E. Operating manual and parts list.

PART 2 - PRODUCTS

- 2.01 PUMPS:
- A. Single stage, end suction, centrifugal type, of cast iron bronze fitted with replaceable bronze casing wear rings, renewable bronze shaft seal, and with enclosed bronze impeller. Suction and discharge flanges shall be ANSI 125 Lb. tapped for NDT gauge cocks.
- 2.02 MOTORS:
- A. Ball bearing high efficiency inverter duty electric motor, shall be non-overloading at any point on pump curve. All motors shall be copper wound premium efficiency meeting NEMA Standard MG1-12.53B. Label on motor shall list nominal efficiency.
- 2.03 SEALS:
- A. Mechanical seal with all metal parts to be 303 stainless steel with "Buna-N" elastomers, Ni-Resist seal and carbon washer.
- 2.04 ACCESSORIES:
- A. Suction and discharge pressure gauge.
 - B. Suction and discharge flexible connection.
 - C. Full size suction strainer with ball valve and hose fitting.
 - D. 10 gauge black steel drip pan under chilled water pump with 3/4" drain line to floor drain.

PART 3 - EXECUTION

3.01 INSTALLATION:

- A. Install in accordance with producer's printed directions. Align and support piping to eliminate strain on pump casing. Install cork-flex isolation pad under floor mounted pipe supports.

3.02 START-UP:

- A. Check entire assembly for correctness of installation, alignment, and control sequencing. Start all component parts in proper sequence. Make all adjustments required to insure that all pumps operate smoothly, quietly, in proper control sequence and to designed capacity.

END OF SECTION

SECTION 15154 – AIR HANDLING UNITS

PART I - PRODUCTS

1.01 ACCEPTABLE MANUFACTURERS:

- A. Provide custom indoor air handling units as manufactured by Temtrol as the basis-of-design. Equipment manufactured by Miller-Picking Custom Master or ISM shall be considered provided the construction specifications, capacities and performance criteria are met.

1.02 GENERAL:

- A. Furnish and install where shown on the plans, welded frame air handling units with construction features as specified below. The units shall be provided and installed in strict accordance with the specifications. All units shall be complete with all components and accessories as specified. Any exceptions must be clearly defined. The contractor shall be responsible for any additional expenses that may occur due to any exception made.

1.03 UNIT DESCRIPTION:

- A. Provide factory-fabricated air handling units with capacity as indicated on the schedule. Units shall have overall dimensions as indicated and fit into the space available with adequate clearance for service as determined by the Engineer. Unit manufacturers shall provide certified ratings conforming to the latest edition of AMCA 210, 310, 500 and ARI 410. All electrical components and assemblies shall comply with NEMA standards. Unit internal insulation must have a flame spread rating not over 25 and smoke developed rating no higher than 50 complying with NFPA 90A, "Standard for the Installation of Air Conditioning and Ventilating Systems." Units shall comply with NFPA 70, "National Electrical Code," as applicable for installation and electrical connections of ancillary electrical components of air handling units. Units shall be UL or ETL listed.
- B. Unit Base / Frame / Floor: Provide a full perimeter welded base frame manufactured with structural steel tubing and C-Channel cross support members. Unit frame shall be from carbon tubular steel, Mig welded to form a unitized assembly for support of all internal components. Base and unit frame shall be painted with a lacquer resisting gray phenolic corrosion inhibitive primer. Base rails shall be fitted with lifting lugs at the corner of the unit or section. The base shall include a 4-inch thick insulated "double bottom" floor with minimum 20 gauge G-90 galvanized outer and 16 gauge G-90 galvanized inner walk-on surface. All floor seams shall be caulked and sealed for an airtight unit. Where access is provided to the unit interior, floor openings shall be covered with walk on steel safety grating. Base frame shall be attached to the unit at the factory.
- C. Exterior Panels: The exterior panel shall be fabricated from formed 16 gauge G-90 galvanized steel with exterior coating as specified below. Flat panel design is not acceptable. The casing structure shall incorporate insulating thermal breaks as required so that, when fully assembled, there exists no path of continuous unbroken metal to metal conduction from inner to outer surfaces. Provide necessary support to limit casing deflection to 1/200 of the narrowest panel dimension. If panels cannot meet this deflection, add additional internal reinforcing. Panels shall be gasketed and secured to the tubular steel frame with 1/4" hex head, zinc plated fasteners and neoprene washers. Outer panels are to be removable without affecting the structural integrity of the unit. All panel seams shall be caulked and sealed for an airtight unit. Leakage rates shall be less than 1% at design static pressure. The exterior panel finish shall be bright spangled galvanized.
- D. Double Wall Construction: Each unit shall have double wall construction with 16 gauge solid galvanized liner in the entire unit. The entire double wall panel shall be removable from the outside if the unit without affecting the structural integrity of the unit.
- E. Insulation: Entire unit to be insulated with a full 4" thick non-compressed fiberglass insulation. The insulation shall have an effective thermal conductivity (C) of .24 (BTU in./sq.ft. F. degrees)

and a noise reduction coefficient (NRC) of 0.70 / per inch thick. The coefficients shall meet or exceed a 3.0 P.C.F. density material rating. Insulation shall meet the erosion requirements of UL 181 facing the air stream and fire hazard classification of 25/50 (per ASTM-84 and UL 723 and CAN/ULC S102-M88). All insulation edges shall be encapsulated within the panel. All perforated sections or single wall units shall have Tuf-Skin insulation with black acrylic coating.

F. Access Doors: The unit shall be equipped with a solid double wall insulated, hinged access doors as shown on the plans. The doorframe shall be extruded aluminum with a built in thermal break barrier and full perimeter gasket. The door shall be hinged using a minimum of two heavy-duty 10 gauge galvanized steel butt hinges. There shall be a minimum of two heavy duty Ventlok 260 handles per door. Provide ETL, UL 1995, and CAL-OSHA approved tool operated safety latch on all fan section access doors.

G. Fans:

1. Fanwall Technology: Fan housing shall be heavy gauge galvanized steel construction. Fan scroll shall be bolted to assembly frame. Fan shall be IRD balanced at design RPM to a vibration velocity less than or equal to .157 inches per second measured at each bearing pad prior to shipment with motor, sheaves, and belts in place. Fan shall be rated in accordance with AMCA 210 for performance and AMCA 300 for sound.

H. Condensate Pan: IAQ style drain pans shall be provided under all cooling coils. The drain pan shall be fabricated from 16 gauge 304 stainless steel. All pans are to be triple pitched for complete drainage with no standing water in the unit. They shall be insulated minimum 3-inch "Double Bottom" construction with welded corners. Provide stainless steel, 1-1/4" MPT drain connection extended to the exterior of the unit base rail. Units in excess of 160 inches shall have drain connections on both sides. All drain connections shall be piped and trapped separately for proper drainage.

I. Filters:

1. Provide filters of the type indicated on the schedule. Factory fabricated filter sections shall be of the same construction and finish as the unit. Face loaded pre and final filters shall have Type 8 frames as manufactured by FARR. Side service filter sections shall include hinged access doors on both sides of the unit. Internal blank-offs shall be provided by the air unit manufacturer as required to prevent air bypass around the filters. The filters shall be as manufactured by Farr, Purolator, AAF or equal. Filters shall be in compliance with ANSI/UL 900 – Test Performance of Air Filters.

2. Filter Gauge: Each Filter bank shall be furnished with Magnehelic filter gauge Dwyer Series 2000.

J. UV Light: Evergreen UV, 120 volts.

END OF SECTION

SECTION 15170 - ROOF MOUNTED OUTSIDE AIR INTAKES AND RELIEF VENTS

PART 1 - GENERAL

- 1.01 See Sections 15000 for related work in other Divisions and Sections.
- 1.02 ACCEPTABLE PRODUCERS:
- A. This specification refers to products produced by Acme Engineering & Manufacturing Company, ILG, Loren Cook Company and Greenheck. AMCA labeled products produced by other producers may be submitted for approval in accord with Division 1 and Section 15000.
- 1.03 SUBMITTALS:
- A. Shop drawings including all pertinent weights and dimensions.
 - B. AMCA Certified rating data.
 - C. Installation instructions.

PART 2 - PRODUCTS

- 2.01 ROOF INTAKES AND RELIEF VENTS:
- A. Construction: Heavy gauge aluminum hood, housing and base, steel frame and factory applied 3 coat epoxy coating on hood. Hinge hood with approved locking device operating in both open and closed positions. Ventilators to be low silhouette trim-line style. See plans for size.
- 2.02 ACCESSORIES:
- A. Curbs: Include 12" high roofed-over type. Fabricated of aluminum with 2" thickness fire resistant glass fiber internal insulation. Curb shall be furnished by vent producer. Hoods shall be installed level.
 - B. Back Draft Dampers: Include all aluminum gravity type, with felt edged blades and nylon bearings.
 - C. Bird Screen: Include ½" mesh aluminum or galvanized steel hardware cloth.

PART 3 - EXECUTION

- 3.01 INSTALLATION:
- A. Install in accordance with submitted instructions. Anchor housing to curb, with cadmium plated self tapping screws, lag screws or bolts as directed by curb construction. Install to withstand 100 MPH winds. Intakes and vents shall be installed level.
- 3.02 CLEANING:
- A. Clean tar and all other soil from housing exterior. Leave ready for Division 7/Caulking.

END OF SECTION

SECTION 15181 - VIBRATION ISOLATION

PART 1 - GENERAL

- 1.01 See Sections 15000 for related work in other Divisions and Sections.
- 1.02 ACCEPTABLE PRODUCERS:
 - A. Those named hereinafter.
- 1.03 SUBMITTALS:
 - A. Data sheets, including all configurations and vibration isolation rating data.
 - B. Installation instructions.

PART 2 - PRODUCTS

- 2.01 FLEXIBLE METAL HOSE:
 - A. Brass construction with brass wire braid covering, 300 psig working pressure, produced by American Brass Co., Mason Industries, Chicago Metal Hose Co., or as approved.
- 2.02 FLEXIBLE COUPLINGS:
 - A. Flanged multiple teflon bellows with guides and restraints, produced by Resist-O-Flex Co., Mercer Rubber Co., Metraflex, or as approved.
- 2.03 ISOLATION PADS:
 - A. One inch isomode pad, sized from 40 to 60 psi loading.
- 2.04 SPRING ISOLATORS FOR FANS AND AIR HANDLING UNITS:
 - A. Shall be selected by equipment producer and furnished with equipment.

PART 3 - EXECUTION

- 3.01 INSTALLATION:
 - A. Install following producer's printed instructions. Make no rigid connections between equipment and building structure.
 - B. Refer to drawings Section 15000 and Specification sections covering individual terms of equipment for other installation instructions.

END OF SECTION

SECTION 15211a - SHEETMETAL DUCTWORK AND ACCESSORIES

PART 1 - GENERAL

- 1.01 See Sections 15000 for related work in other Divisions and Sections.
- 1.02 ACCEPTABLE PRODUCERS:
- A. Those specified herein.
- 1.03 SUBMITTALS REQUIRED:
- A. Submittal shall include complete technical and code conformance data.
 - B. Submittals Required:
 - 1. Volume Control Dampers.
 - 2. Damper Regulators.
 - 3. Access Doors.
 - 4. Sealant.
- 1.04 CODES AND STANDARDS:
- A. SMACNA Duct Construction Standards.
 - B. NFPA 90A.
 - C. UL 555S.
 - D. UL 555.
 - E. UL 181.

PART 2 - PRODUCTS

- 2.01 DUCTWORK:
- A. Metal: Galvanized sheet steel, gauges as listed in referenced standard. Stamp sheet metal gauge and manufacturer's identifications on each sheet. Break sheets so all identification stamps are exposed.
 - B. Flexible Joints: 30 ounce neoprene coated glass fabric, conforming to NFPA-90A, 1985, 2-1.2.
 - C. Duct Liner: **NOT PERMITTED.**
 - D. Duct Liner Adhesive: **NOT USED.**
- 2.02 SEALANTS:
- A. Sealants shall be UL labeled indicating flame spread and smoke developed ratings. Flame spread shall not exceed 25 and smoke developed rating shall not exceed 50. Benjamin Foster 30-02, Insul-coustic 1C-451 or pre-approved equal.
- 2.03 DAMPERS:
- A. Volume Control Dampers:
 - 1. General: Dampers shall not rattle or generate objectionable air noise throughout operating range. Maximum leakage shall not exceed 6 CFM per square foot at 1" water gauge static pressure differential. Dampers shall be rated for use in systems with total static pressure of 8" water gauge. Blades shall be positively locked to axles without use of screws, bolts or welds.

2. Construction:

- a) Frame: Rectangular, 16 gauge galvanized steel. Round and flat oval, 20 gauge galvanized steel. Rectangular frames shall be interlocking design without bolts, screws or rivets.
 - b) Blades: Rectangular, 16 gauge galvanized steel: 6" maximum width. Round, two layers galvanized steel, 14 gauge equivalent thickness.
 - c) Seals: Round seal sandwiched between blade layers. Rectangular blade seal extruded synthetic, jamb seal metallic compression type.
 - d) Bearings: Molded synthetic non-stick each end of blade shaft.
 - e) Linkages: Rectangular multi-blade linkage concealed in frame operated from single shaft.
- B. Automatic Dampers: Automatic dampers are furnished under Section 15402 and shall be installed under this section.

2.04 ACCESS DOORS:

- A. Heavy gauge galvanized steel frame and double wall door with 1" insulation between walls. Provide a continuous neoprene or rubber gasket between door and frame. Door shall be held in frame with cam latches. Low pressure access doors shall seal tight against 4" water gauge static pressure across door. Medium and high pressure doors shall seal tight against 12" water gauge static pressure differential.

2.05 ACCESSORIES:

- A. Damper Regulators: Furnish insulation stand-off brackets for regulators used on externally insulated ductwork.
 - 1. Surface Type: Key operated, locking quadrant with bearing in quadrant, neoprene or rubber gasket and damper position indicator. Young Regulator Co. No. 1G or pre-approved equal.

PART 3 - EXECUTION

3.01 DUCTWORK FABRICATION:

- A. Fabricate ductwork in accordance with SMACNA Standards listed in Paragraph 1.04 hereinbefore. Pay particular attention to ductwork and seam reinforcing, metal thickness and support requirements.
- B. Use double vane turning vanes in all rectangular square elbows. All radius elbows shall be made with inside radius of W/2.
- C. All joints and seams in ductwork shall be sealed with an approved sealant. Gaskets shall be used in flanged joints. Sealants shall be applied as shown in referenced standards and shall meet Seal Class A Standard in SMACNA Low Pressure Duct Standards for design pressure below 4" water gauge and SMACNA High Velocity Duct Standards for pressure above 4" water gauge. Do not use tape.
- D. Reinforce insulated rectangular ductwork.

3.02 DUCTWORK INSTALLATION:

- A. Hanger type and spacing shall conform to the reference SMACNA Standards.

- B. Ductwork shall be free of sag, bulge, vibration and leakage.
- C. Remove rubbish and trash from ductwork prior to installing terminals and dampers.
- D. All ductwork larger than 12" or 12" round shall have approved access doors installed for cleaning access. Locate doors for adequate accessibility not over 20 feet apart and at the base of each riser.
- E. Install approved access doors on entering air side of duct mounted heating coils. Doors shall be adequate in size to permit cleaning and inspection of coils.
- F. Installation of automatic dampers shall conform to printed instructions from the manufacturer.

END OF SECTION

SECTION 15216a - EXTERIOR INSULATION OF AIR DISTRIBUTION ITEMS

PART 1 - GENERAL

1.01 See Sections 15000 for related work in other Divisions and Sections.

1.02 ACCEPTABLE PRODUCERS:

- A. Knauf, Schuller and those listed hereinafter.

1.03 SUBMITTALS:

- A. Producer's data sheet on each product.

PART 2 - PRODUCTS

2.01 INSULATION BOARD INSIDE BUILDING:

- A. Six (6) PCF density fiberglass 1-½" thickness (R=6.4) with UL rated 0.0025 inch aluminum foil vapor barrier.

2.02 INSULATION WRAP:

- A. One (1) PCF density fiberglass 2" thickness (R=6.1) with UL rated 0.0025 inch aluminum foil vapor barrier.

2.03 INSULATION FINISH CEMENT:

- A. Johns Manville No. 301, Baldwin Ehret Hill No. 1 insulating cement.

PART 3 - EXECUTION

3.01 GENERAL:

- A. Use insulation board in exposed indoor locations for externally insulated rectangular ductwork and duct mounted heating coils inside building, flexible blanket insulation on flexible joint connections at inlets and outlets of air conditioning units. Adhere insulation to duct with 100 percent coverage using approved insulation adhesive. Additionally secure insulation with ¼" wide machine applied steel bands as recommended by manufacturer.
- B. Seal joints, punctures and breaks in aluminum vapor barrier with 4" wide strip of open mesh glass fabric applied over one coat of vapor barrier mastic. When dry apply second coat of general purpose mastic with aluminum grey color. Or use a pressure sensitive, UL labeled aluminum joint sealing tape in lieu of glass fabric and mastic.
- C. Insulation thickness is indicated on drawings.

END OF SECTION

SECTION 15235 - ELECTRIC UNIT MOUNTED HEATING COIL

PART 1 - GENERAL

1.01 See Sections 15000 for related work in other Divisions and Sections.

1.02 SUBMITTALS:

- A. Shop drawings
- B. Certified Rating Data
- C. Installation Instructions

PART 2 - PRODUCTS

2.01 ELECTRIC HEAT COILS: SEE DRAWINGS

- A. To have 80% nickel, 20% chromium Type A resistance coils, insulated by floating ceramic bushings and supported in flanged aluminized or galvanized steel frame. Recess bushings into embossed openings and stack into supporting brackets spaced at not more than 4" centers. This specification refers to products produced by Brasch or Markel.

2.02 ELECTRIC HEAT CONTROLS:

- A. Provide Following Built-In Controls in NEMA 1 Enclosures:
 - 1. Magnetic contactor, UL tested for use on electric unit heaters of specified capacity for not less than 100,000 cycles.
 - 2. Normally open S.P.S.T. relay energized from power wiring to fan motor of air handling unit and interconnected to prevent heater from operating unless fan motor is energized.
 - 3. Automatic reset type high limit thermostat which de-energizes heater if temperature in vicinity of electric heater exceeds producer's recommended temperature.
 - 4. Semi-automatic reset type higher limit thermostat which de-energizes heater if temperature in heater exceeds setting of automatic reset controller by more than 50 degrees F. This control to require manual reset on trip.
 - 5. Built-in, renewable, temperature sensitive, glass enclosed, fusible link and clip holder in each phase; which will positively break power circuit to heater even with malfunction of magnetic contactor. Temperature rating of this unit to exceed automatic and semi-automatic controls.
 - 6. Air Flow switch to de-energize heater, control circuit transformer with fused protection and built-in snap-acting, door interlock disconnect switch.

PART 3 - EXECUTION

3.01 INSTALLATION:

- A. Follow Producer's printed instructions and details on drawings.

END OF SECTION

SECTION 15262d - VARIABLE FREQUENCY DRIVES

PART 1 - GENERAL

1.01 GENERAL:

- A. Drawings and General Provision of Contract, including General and Supplementary Conditions and Division 1 Specification Sections, apply to work of this section.
- B. Division 15 - Basic Mechanical Materials and Methods Sections apply to work of this section.
- C. Extent of Adjustable Frequency Drive work required by this section is indicated on drawings and schedules, and by requirements of this section. Control sequences are specified on drawings.
- D. Refer to Division 16 Sections for raceways and wiring - not work of this section.
- E. Interlock Wiring (120 volt and greater) between electrically operated equipment units; and between equipment and field installed control devices. Interlock wiring specified as factory installed is work of this section.
- F. Provide the Following Electrical Work as work of this section, complying with requirements of Division 16 sections: Control wiring and signal wiring (24 volt and lower) between field installed controls, indicating devices, and unit control panels.

1.02 REFERENCES:

- A. NEMA ICS 3.1 - Safety Standards for Construction and Guide for Selection, Installation and Operation of Variable Frequency Drive Systems.
- B. NEMA 250 - Enclosures for Electrical Equipment (1000 Volts Maximum).
- C. UL, and cUL Approved.
- D. IEEE Standard 444 (ANSI-C343).
- E. IEEE Standard 519.
- F. IEC: 146A.
- G. UL 508C (Power Conversion).
- H. CSA 22.2 No. 14-95 (Industrial Control Equipment).
- I. UL 1995 (Plenum rating).
- J. EN 50178 (LVD).
- K. EN 61800-3.
- L. IEC 529.
- M. FCC CFR 47 Part 15 Subpart B.

1.03 SUBMITTALS:

- A. Shop Drawings shall include: Wiring diagrams, electrical schematics, front and side views of enclosures, overall dimensions, conduit entrance locations and requirements, nameplate legends, physical layout and enclosure details.

- B. Product Data: Provide data sheets showing; voltage, ratings of customer use switching and over-current protective devices, short circuit ratings, and weights.
- C. Manufacturer's Installation Instructions and Technical Manuals: Indicate application conditions and limitations of use stipulated by product testing agency specified under regulatory requirements. Include instructions for storage, handling, protection, examination, preparation, installation, and starting of adjustable speed drive. Document the sequence of operation, cautions and warnings, trouble shooting procedures, spare parts lists and programming guidance.

1.04 QUALITY ASSURANCE:

- A. VFD shall have a minimum MTBF (mean time between failure) rating of 28 years (245,280 Hours).

1.05 OPERATION AND MAINTENANCE DATA:

- A. Submit under provisions of Section 01700.
- B. Include instructions for starting and operating VFD, and describe operating limits, which may result in hazardous or unsafe conditions.

1.06 QUALIFICATIONS:

- A. Manufacturer must have a minimum of 25 years of documented experience, specializing in variable frequency drives.

1.07 DELIVERY, STORAGE, AND HANDLING:

- A. Deliver, store, protect and handle products to site, under provisions of Section 01610.
- B. Accept VFD on site in original packing. Inspect for damage.
- C. Store in a clean, dry space. Maintain factory wrapping, or provide an additional heavy canvas or heavy plastic cover, to protect units from dirt, water, construction debris, and traffic.
- D. Handle carefully, in accordance with manufacturer's written instructions, to avoid damage to components, enclosure, and finish.

1.08 WARRANTY:

- A. Provide VFD warranty, for two (2) years from date of substantial completion, not to exceed 18 months from date of shipment. Warranty shall include parts, and labor allowance for repair hours. Provide factory start-up.

PART 2 - PRODUCTS

2.01 MANUFACTURERS:

- A. VFD shall be manufactured by Yaskawa Electric. Equal products by Danfoss and Safetronics are acceptable.
- B. Drives and motors shall be by the same manufacturer. Motors should be inverter duty rated, per NEMA MG1 parts 30 and 31, for motor-drive compatibility.

2.02 DESCRIPTION:

- A. Provide enclosed variable frequency drives suitable for operation at the current, voltage, and horsepower indicated on the schedule. Conform to requirements of NEMA ICS 3.1.

2.03 RATINGS:

- A. VFD must operate, without fault or failure, when voltage varies plus 10% or minus 15% from rating, and frequency varies plus or minus 5% from rating.
- B. Displacement Power Factor: 0.98 over entire range of operating speed and load.
- C. Operating Ambient Temperature: -10 degrees C to 40 degrees C (14 degrees F to 104 degrees F)
- D. Humidity: 0% to 95% non-condensing.
- E. Altitude: to 3,300 feet, higher altitudes achieved by derating.
- F. Minimum Efficiency: 96% at half speed; 98% at full speed.
- G. Starting Torque: 100% starting torque shall be available from 0.5 Hz. to 60 Hz.
- H. Overload capability: 110% of rated FLA (Full Load Amps) for 60 seconds; 180% of rated FLA, instantaneously.
- I. The VFD must meet the requirements for Radio Frequency Interference (RFI) above 7 MHz as specified by FCC regulations, part 15, subpart J, Class A devices.
- J. Total Harmonic Distortion (THD) compliance: Given the information provided by the customer's electric power single line diagram and distribution transformer data, the VFD manufacturer shall carry out an analysis of the system. The analysis reviews the potential for the proposed equipment, and any existing equipment, to meet IEEE 519 (tables 10.2 and 10.3) recommendations at the Point of Common Coupling (PCC). The result of the analysis shall determine if additional power quality improvement measures should be included in the proposal to meet the THD recommendations of IEEE 519. The PCC shall be at the primary side of the main distribution transformer.
- K. VFD's must have a minimum short circuit rating of 65K amps RMS (100K amps RMS with a DC bus reactor) without additional input fusing.

2.04 DESIGN:

- A. VFD shall employ microprocessor based inverter logic, isolated from all power circuits.
- B. VFD shall include surface mount technology with protective coating.
- C. VFD shall employ a PWM (Pulse Width Modulated) power electronic system, consisting of:
 - 1. Input Section: VFD input power stage shall convert three-phase AC line power into a fixed DC voltage via a solid state full wave diode rectifier, with MOV (Metal Oxide Varistor) surge protection.
 - 2. Intermediate Section:
 - a) DC bus as a supply to the VFD output Section shall maintain a fixed voltage with filtering and short circuit protection.
 - b) DC bus shall be interfaced with the VFD diagnostic logic circuit, for continuous monitoring and protection of the power components.
 - c) 30 HP to 150 HP @ 208 VAC, 30 HP to 150 HP @ 240 VAC, and 40 HP to 500 HP 480 VAC, VFDs shall include a DC bus reactor to minimize reflected harmonics.
 - 3. Output Section:

- a) Insulated Gate Bipolar Transistors (IGBTs) shall convert DC bus voltage to variable frequency and voltage.
 - b) The VFD shall employ PWM sine coded output technology to power the motor.
- D. The VFD must be selected for operation at carrier frequencies at or above 5 kHz without derating to satisfy the conditions for current, voltage, and horsepower as indicated on the equipment schedule. Exception to this requirement is allowed only for VFDs providing 506 amps or more.
- E. VFD shall have an adjustable carrier frequency: The carrier frequency shall have a minimum of six settings to allow adjustment in the field.
- F. VFD shall have embedded Building Automation System (BAS) protocols for network communications; Johnson Metasys N2, Siemens System 600 APOGEE, and Modbus/Memobus. These protocols shall be accessible via a RS-422/485 communication port.
- G. VFD shall have a quick disconnect, removable control I/O terminal block to simplify control wiring procedures.
- H. VFD shall include two independent analog inputs. One shall be 0-10 VDC. The other shall be programmable for either 0-10 VDC or 4-20 mA. Either input shall respond to a programmable bias and gain.
- I. VFD shall include a minimum of seven multi-function digital input terminals, capable of being programmed to determine the function on a change of state. These terminals shall provide up to 30 functions, including, but not limited to:
- 1. Remote/Local operation selection;
 - 2. Detection of external fault condition;
 - 3. Remote Reset;
 - 4. Multi-step speed commands;
 - 5. Run permissive;
 - 6. Floating control.
- J. VFD shall include two 0-10 VDC or 4-20 mA analog output for monitoring, or "speed tracking" the VFD. The analog output signal will be proportional to output frequency, output current, output power, PI (Proportional & Integral control) feedback or DC bus voltage.
- K. VFD shall provide terminals for remote input contact closure, to allow starting in the automatic mode.
- L. VFD shall include at least one external fault input, which shall be programmable for a normally open or normally closed contact. These terminals can be used for connection of firestats, freezestats, high pressure limits or similar safety devices.
- M. VFD shall include two form "A" contacts and one form "C" contact, capable of being programmed to determine conditions that must be met in order for them to change state. These output relay contacts shall be rated for at least 5A at 120 VAC and shall provide up to 18 functions, including, but not limited to:
- 1. Speed agree detection;
 - 2. Low and high frequency detection;
 - 3. Missing frequency reference detection;
 - 4. Over torque/Under torque detection;
 - 5. Drive Running;
 - 6. Drive Faulted.
- N. VFD shall include a power loss ride through of 2 seconds.

- O. VFD shall have DC injection braking capability, to prevent fan "wind milling" at start or stop, adjustable, current limited.
- P. VFD shall have a motor preheat function to prevent moisture accumulation in an idle motor.
- Q. VFD shall include diagnostic fault indication in selected language, last 10 faults storage and heat-sink cooling fan operating hours.
- R. VFD shall have a digital operator with program copy and storage functions to simplify set up of multiple drives. The digital operator shall be interchangeable for all drive ratings.
- S. VFD shall include a front mounted, sealed keypad operator, with an English language (or one of 6 additional international languages) illuminated LCD display. The operator will provide complete programming, program copying, operating, monitoring, and diagnostic capability. Keys provided shall include industry standard commands for Hand, Off, and Auto functions.
- T. VFD plain language display shall provide readouts of; output frequency in hertz, PI feedback in percent, output voltage in volts, output current in amps, output power in kilowatts, D.C. bus voltage in volts, interface terminal status, heat-sink temperature and fault conditions. All displays shall be viewed in an easy-to-read illuminated LCD with International language selectability.
- U. VFD unit shall include the following meters to estimate use of energy:
 - 1. Elapsed Time Meter;
 - 2. Kilowatt Meter;
 - 3. Kilowatt Hour Meter.
- V. VFD shall include PI control logic, to provide closed loop set-point control capability, from a feedback signal, eliminating the need for closed loop output signals from a building automation system. The PI controller shall have a differential feedback capability for closed loop control of fans and pumps for pressure, flow or temperature regulation in response to dual feedback signals.
- W. An energy saving sleep function shall be available in both open loop (follower mode) and closed loop (PI) control, providing significant energy savings while minimizing operating hours on driven equipment. When the sleep function senses a minimal deviation of a feedback signal from set-point, or low demand in open loop control, the system reacts by stopping the driven equipment. Upon receiving an increase in speed command signal deviation, the drive and equipment resume normal operation.
- X. VFD shall include loss of input signal protection, with a selectable response strategy including speed default to a percent of the most recent speed.
- Y. VFD shall include electronic thermal overload protection for both the drive and motor. The electronic thermal motor overload shall be approved by UL. If the electronic thermal motor overload is not approved by UL, a separate UL approved thermal overload relay shall be provided in the VFD enclosure.
- Z. VFD shall include the following program functions:
 - 1. Critical frequency rejection capability: 3 selectable, adjustable deadbands.
 - 2. Auto restart capability: 0 to 10 attempts with adjustable delay between attempts.
 - 3. Ability to close fault contact after the completion of all fault restart attempts.
 - 4. Stall prevention capability.
 - 5. "S" curve soft start capability.
 - 6. Bi-directional "Speed search" capability, in order to start a rotating load.
 - 7. 14 preset and 1 custom volts per hertz pattern.
 - 8. Heat-sink over temperature speed fold back capability.

9. Terminal status indication.
10. Program copy and storage in a removable digital operator.
11. Current limit adjustment capability, from 30% to 200% of rated full load current of the VFD.
12. Motor pre-heat capability.
13. Input signal or serial communication loss detection and response strategy.
14. Anti "wind-milling" function capability.
15. Automatic energy saving function.
16. Under torque/Over torque Detection.
17. Preset speeds.

AA. VFD shall include factory settings for all parameters, and the capability for those settings to be reset.

BB. VFD shall include user parameter initialization capability to re-establish project specific parameters.

CC. VFD shall include the capability to adjust the following functions, while the VFD is running:

1. Speed command input.
2. Acceleration adjustment from 0 to 6000 seconds.
3. Deceleration adjustment from 0 to 6000 seconds.
4. Select from 5 preset speeds.
5. Analog monitor display.
6. Removal of digital operator.

2.05 BYPASS:

A. Three Contactor Manual Bypass shall be provided. VFD and bypass components shall be mounted inside a common NEMA 12 enclosure, fully pre-wired, and ready for installation as a single UL listed device. Bypass shall include the following:

1. Input, output, and bypass contactors, to disconnect power to the VFD, when the motor is running in the bypass mode.
2. 120 VAC control transformer, with fused primary.
3. Magnetic overload relay, to protect the motor while operating in the bypass mode.
4. Circuit breaker/disconnect switch, with a pad-lockable through-the-door handle mechanism.
5. Control and safety circuit terminal strip.
6. Drive/Bypass selector switch, Hand/Off/Auto selector switch, Normal/Test selector switch.
7. Switch selectable smoke purge, auto transfer to bypass and remote transfer functions.
8. Pilot lights (22 mm LEDs) for "Control Power ", "Drive Fault", "Drive Run", "Bypass Run", "OL/Safety Fault" and "Smoke Purge".
9. Normal/Test selector switch, shall allow testing and adjustment of the VFD, while the motor is running in the bypass mode.
10. Hand/Off/Auto selector switch shall provide the following operation:
 - a) Hand Position - The drive is given a start command, operation is via the local speed input (digital operator or speed pot.). If in bypass mode, the motor is running.
 - b) Off Position - The start command is removed, all speed inputs are ignored, power is still applied to the drive. If in bypass mode, the motor is stopped.

- c) Auto Position - The drive is enabled to receive a start command and speed input from a building automation system. If in bypass mode, the motor start/stop is controlled by the building automation system.
- 11. Annunciation contacts for drive run, drive fault, bypass run and motor OL/safety fault.
- 12. Damper control circuit with end of travel feedback capability.
- 13. VFD operator/keypad selection, LCD types.
- 14. H/O/A control panel selection, Touch pad switch types.
- B. Soft start on transfer to bypass shall be provided.
- C. Enclosure: NEMA 12 FVFF (Forced Ventilation inlet Filter and outlet Filter) enclosures with filters and blower.
- D. RFI (Radio Frequency Interference) filters to further attenuate possible VFD generated noise shall be provided.
- E. Current limiting input fusing for short circuit protection of VFD semiconductor devices shall be provided.
- F. Pressure transducer (3 to 15 PSI input = 0 to 10 V DC output), to convert a pneumatic signal into an VFD Speed Command Input shall be provided.
- G. Line reactors shall be provided on the input side of the drive for harmonic suppression.
- H. DC bus reactor, to attenuate harmonic distortion shall be provided on: 20 HP and below @ 208 VAC, 25 HP and below @ 240 VAC, and 30 HP and below @ 480 VAC.
- I. 12-Pulse phase shifting transformer shall be provided on: 25 HP to 150 HP @ 208 VAC, 30 HP to 150 HP @ 240 VAC, and 40 HP to 500 HP @ 480 VAC models to minimize THD generated by the VFD.
- J. 18-Pulse phase shifting transformer shall be provided on: 25 HP to 150 HP @ 208 VAC, 30 HP to 150 HP @ 240 VAC, and 40 HP to 500 HP @ 480 VAC models to minimize THD generated by the VFD.
- K. Analog output (4-20 mA), shall be provided to make available two analog current outputs.
- L. Multiple motor operation; Two motor "OR" control.
 - 1. Two motor "OR" control allows local or remote motor operation selection between two individual motors (pump #1 "OR" auto "OR" pump #2).
- M. Serial communication gateway for BACnet shall be provided via an isolated MS-TP RS-485 circuit board.
- N. Relays, motor overload or time delay shall be provided.
- O. VFD Input MCP circuit breaker/disconnect shall be provided.
- P. Engraved cabinet nameplates shall be provided.

2.06 SOURCE QUALITY CONTROL:

- A. In-circuit testing of all printed circuit boards shall be conducted, to insure the proper mounting and correct value of all components.
- B. All printed circuit boards shall be burned in for 96 hours, at 85 degrees C.
- C. Final printed circuit board assemblies shall be functionally tested, via computerized test equipment. All tests and acceptance criteria shall be preprogrammed. All test results shall be stored as detailed quality assurance data.
- D. All fully assembled controls shall be functionally tested, with fully loaded induction motors. The combined test data shall then be analyzed, to insure adherence to quality assurance specifications.
- E. Inspect and production test, under load, each completed VFD assembly.

PART 3 - EXECUTION

3.01 EXAMINATION:

- A. Verify that surface is suitable for VFD installation.
- B. Do not install VFD until the building environment can be maintained, within the service conditions required by the manufacturer.

3.02 INSTALLATION:

- A. Install VFD where indicated, in accordance with manufacturer's written instructions and NEMA ICS 3. Provide slotted angles or channel bars with mounting hardware for securing drives to wall.
- B. Tighten accessible connections and mechanical fasteners after placing VFD.
- C. Provide a nameplate label on each VFD, identifying rated horsepower, full load amperes, model number, service factor and voltage/phase rating.
- D. Inspect completed installation for physical damage, proper alignment, anchorage, and grounding.

3.03 MANUFACTURER'S FIELD SERVICES:

- A. Prepare and start systems.

3.04 ADJUSTING:

- A. Make final adjustments to installed VFD, to assure proper operation of fan systems.

END OF SECTION

SECTION 15302 - BLACK STEEL PIPING

PART 1 - GENERAL

- 1.01 See Sections 15000 for related work in other Sections and Divisions.
- 1.02 See Section 15325 - Insulation for Equipment and Piping.

PART 2 - PRODUCTS (See Systems Sections to determine where different products shall be used.)

2.01 GENERAL:

- A. Use threaded, welded and/or flanged pipe as governed by normal pipe size conditions and as shown on mechanical drawings.

2.02 PIPE:

- A. Conform to ASTM A53-86, Grade B seamless black steel.

2.03 FITTINGS:

- A. Threaded Cast Iron: Dimensions as ANSI B16.4, threads as ANSI B2.1; material as ASTM-A 126, Class A.
- B. Threaded Malleable Iron: Dimensions as ANSI B16.3, threads as ANSI B2.1; material as ASTM A-47 Grade 32510.
- C. Socket Welded: Dimensions as ANSI B16.11; material as ASTM A-181, Grade 1 forged steel.
- D. Butt Welded: Dimensions as ANSI B16.9; material as ASTM A-234.
- E. Flanged Cast Iron: Dimensions as ANSI B16.1; material as ASTM A-126 Class B; 125 lb. pressure class.

2.04 FLANGES:

- A. Dimensions as ANSI B16.5; material as ASTM A-181; 150 lb. pressure class.

2.05 FLANGE BOLTS AND NUTS:

- A. ASTM A-307 Grade B.

2.06 JOINT COMPOUND:

- A. As formulated by regionally recognized producer for each particular application.

2.07 THREAD TAPE:

- A. Teflon pipe thread tape produced by regionally recognized producer.

PART 3 - EXECUTION

3.01 LAYOUT:

- A. Run parallel with building walls. Keep free of contact with building construction, including installed equipment. Cut pipe from measurements taken at site, not from drawings. Arrange piping to permit system's drainage.

3.02 JOINTS:

- A. Threaded: Ream ends of pipe after threading to remove burrs. Conform thread stand-off to ASTM A-53, tables A5 and A6. Use joint compound or tape on male thread only.
- B. Welded: Conform to "Code for Pressure Piping," ANSI B31.1, Section 6, paragraphs 621 and 632; and "Standard Qualification Procedures" of American Welding Society. All welders are to be certified in accord with referenced codes. Show welder's certificates to Consulting Engineer at time welder is assigned to job. Architect/Engineer will require welder recertification if welding work is unsatisfactory when Engineer inspects it.
- C. Flanged: Torque flange bolts to insure uniform gasket compression. Align flanges to prevent distortion when bolts are tightened. Project bolts _" to _" beyond nut face when tight.

END OF SECTION

SECTION 15312 - COPPER DRAINAGE PIPING

PART 1 - GENERAL

1.01 See Sections 15000 for related work in other Sections and Divisions.

PART 2 - PRODUCTS

2.01 SOIL, WASTE AND VENT PIPING, INCLUDING WASTE ARMS:

- A. Type L copper tube, ASTM B-88, in sizes up to 2", type DWV copper tube, ASTM B-306, in sizes 3" and larger, with wrought copper or brass drainage fittings, NIBCO 800 series or 900 series.

2.02 CONDENSATE DRAINS:

- A. Same as 2.01.

PART 3 - EXECUTION

3.01 JOINTS:

- A. Clean pipe and fittings with sand cloth, apply ASTM B32 solder with ASTM B813 lead-free flux. Leave uniform and visible solder ring on all joints.

3.02 CAPS:

- A. Solder copper test caps on all waste arms and other open copper drainage piping until installation of fixture.

3.03 NOTE:

- A. Copper tubing and drainage fittings as specified above may be used in certain areas of the sanitary or storm drainage system because of space limitations or other special requirements. Approval is required prior to installation.

END OF SECTION

SECTION 15323 - GAUGES, THERMOMETERS AND THERMOMETER WELLS

PART 1 - GENERAL

1.01 See Sections 15000 for related work in other Divisions and Sections.

1.02 ACCEPTABLE PRODUCERS:

A. Those listed hereinafter.

1.03 SUBMITTALS:

A. Producer's data sheets on each product.

PART 2 - PRODUCTS

2.01 PRESSURE GAUGES:

A. Ashcroft, 4-½" dial bourdon tube gauge with isolation cock. Select range of gauge so that normal operating pressure is approximately at center of dial and the highest possible pressure does not exceed the range. Provide dampener for gages subjected to pulsating flow. Provide siphon and cock for steam gages. Gauge accuracy shall be within ½ of 1% of full scale range.

2.02 THERMOMETERS:

A. Terice 2 ½" inch diameter dial, aluminum case, copper stem, separable socket adjustable type. Select range of thermometer such that normal operating temperature is at approximate center scale and highest possible temperature does not exceed full scale.

2.03 THERMOMETER WELLS:

A. Terice No. 5550 304 stainless steel, 2 inch extension neck.

PART 3 - EXECUTION

3.01 GENERAL:

A. Install thermometers with at least 75% of stem in moving fluid. This may require increased stem length over the standard specified. If pipe size is less than 4 inch, provide a tee and install thermometer socket at a change in direction of piping.

B. Install test wells with longitudinal axis vertical and removable screw plug at top. If pipe size is 4 inch or smaller, provide a tee in piping and install well at change in direction of the piping.

C. Provide pressure gauge tappings with gauge cocks at all locations where gauges are indicated.

END OF SECTION

SECTION 15325 - INSULATION FOR EQUIPMENT AND PIPING

PART 1 - GENERAL

- 1.01 See Sections 15000 for related Divisions and Sections.
- 1.02 Composite Insulation Systems (insulation, jacket, sealants, mastics and adhesives) shall have a flame spread index of 25 or less and a smoke developed index of 50 or less, as tested by ASTM E 84 (NFPA 255) method.
- 1.03 ACCEPTABLE PRODUCERS:
- A. Knauf, Schuller and those listed hereinafter.
- 1.04 SUBMITTALS:
- A. Producer's data sheets on each product.

PART 2 - PRODUCTS

- 2.01 CELLULAR GLASS:
- A. Federal specification HHI 551E.
- 2.02 FLEXIBLE ELASTOMERIC INSULATION:
- A. Armaflex AP pipe insulation or pre-approved equal. Seal seams and butt joints with Armstrong 520 adhesive.

PART 3 - EXECUTION

- 3.01 GENERAL:
- A. Insulation is not to be installed until the piping systems have been checked and found free of all leaks. Surfaces shall be clean and dry before attempting to apply insulation. A professional insulator with adequate experience and ability shall install insulation.
- 3.02 CELLULAR GLASS:
- A. Use for chilled water piping. Thickness shall be 1-½" for piping smaller than 6" and 2" thickness for piping 6" and larger.
 - B. Above Ground Chilled Water Piping: Fit insulation to pipe and fittings to eliminate voids. After fitting, butter all joints with vapor barrier sealant and apply bedding mastic to inside of insulation (not to pipe). Install insulation on pipe and fittings with joints tightly fitted and secure with two stainless steel wires on each length of insulation.
 1. Finish insulation in concealed areas by applying a heavy coat of vapor barrier sealant reinforced with open weave glass fabric overlapping seams at least 2 inches. When sealant has thoroughly dried, apply a finish coat of general purpose mastic as smooth as possible.
 2. Finish insulation in exposed indoor locations by applying heavy coat of vapor barrier sealant to the exterior of the cellular glass. Cover straight piping with 0.016" thickness smooth aluminum jacket fastened with stainless steel bands on no more than 12" centers. Use factory made 0.024" aluminum covers for fittings and valves. Provide removable end caps for strainers.

3.03 FLEXIBLE ELASTOMERIC INSULATION:

- A. Insulate condensate drain piping from air conditioning units with ½ inch thickness.
- B. Mitre cut insulation to fit pipe fittings.

END OF SECTION

SECTION 15328 - VALVES NOT PART OF CONTROL SYSTEMS

PART 1 - GENERAL

1.01 See Sections 15000 for related work in other Divisions and Sections.

1.02 SUBMITTALS:

- A. Producers' data sheets on each product.

1.03 ACCEPTABLE PRODUCERS:

- A. Those listed hereinafter.

PART 2 - PRODUCTS

2.01 GENERAL:

- A. Valves and check valves may not be indicated in every instance on the drawings, but whether or not shown, all valves and check valves necessary to the proper operation of the system shall be furnished and installed by subcontractor in an approved manner and location. In general, valves are to be installed in accordance with typical details shown on drawings. Valves on steel pipe 3" and smaller shall be threaded pattern; valves on pipe 3-1/2" and larger, flanged pattern and valves on copper piping systems, solder pattern. Pressure ratings given for valves are steam working pressure. Valves shall have rising stems. Valves installed 7 feet or higher above the floor shall have chain wheel operators.

2.02 GLOBE VALVES:

- A. 3" and smaller, rising stem, iron wheel, rough brass body, screwed or union bonnet with bronze bonnet and gland nut - 125 PSI class with integral seat and renewable brass plug or Buna-N disc as recommended by manufacturer for particular service.

| THREADED PATTERN | SOLDERED PATTERN |
|------------------|------------------|
| Crane 1 or 2 | Powell 1823 |
| Powell 650 | Stockham B-24 |
| Stockham B-16 | Hammond IB-418 |
| Walworth 3058 | |
| Hammond IB-440 | |

2.03 GATE VALVES:

- A. 3" and smaller threaded valves and 4" and smaller solder pattern valves, rising stem, iron wheel, rough brass body, solid wedge disc, screwed bonnet and finished gland nut - 125 PSI class.

| THREADED PATTERN | SOLDERED PATTERN |
|-------------------|-------------------|
| Crane 428-VB | Crane No. 1334 |
| Walworth No. 2 | Lunkenheimer 2132 |
| Lunkenheimer 3127 | Powell 1821w |
| Powell 2700 | Stockham B-109 |
| Stockham B-105 | Hammond IB-635 |
| Hammond IB-617 | |

2.04 GATE VALVES:

- A. 3-½" and larger; except for solder valves as noted above shall be flanged type with cast iron body, brass trim, brass seats, rising stem and iron wheel - 125 PSI class.

| FLANGED PATTERN | | |
|-------------------|----------------|-----------------|
| Crane 465-½ | Powell 1793 | Walworth 8726F |
| Lunkenheimer 1430 | Stockham G-623 | Hammond IR-1140 |

2.05 BALL VALVES:

- A. Nibco full port, bronze, two-piece body, chrome plated ball, blow-out proof stem, reinforced TFE seats, federal spec WW-V-35B, Type II, Class A, Style 3. Model 5-585-70 two inch (2") and smaller solder pattern. Class 150 flanged pattern, stainless steel ball and stem, stainless one-piece body.

2.06 SWING CHECK VALVES 3" AND SMALLER:

- A. Threaded or solder ends, 125 PSI steam pressure rating, wye pattern with rough bronze body, bronze bonnet and gland nut and renewable bronze disc.

| THREADED PATTERN | SOLDERED PATTERN |
|-------------------|-------------------|
| Crane 37 | Crane 1334 |
| Lunkenheimer 2144 | Lunkenheimer 2145 |
| Hammond IB-940 | Hammond IB-941 |

2.07 SWING CHECK VALVES LARGER THAN 3":

- A. Shall be flanged, wye pattern, 125 PSI steam pressure iron body swing check with renewable brass seat, disc and trim.

| FLANGED PATTERN | | |
|-------------------|----------------|-----------------|
| Crane 373 | Powell 559 | Walworth M-928F |
| Lunkenheimer 1790 | Stockham G-931 | Hammond IR-1124 |

2.08 GLOBE STYLE SILENT CHECK VALVES:

- A. Iron body, bronze seat and disc, stainless steel spring bronze bushing and spring seat, 150 lb. flange drilling. Metraflex #900 Series or Hammond IR9354A

2.09 BUTTERFLY VALVES:

- A. ASTM A126 Class B Body, ASTM 13148 65T Grade 9D disc, E.P.D.M. seat, one piece AISI 304 stainless steel shaft, 200 PSI rating, LUG style. Furnish gear drive with memory stop or sizes 4 inches or larger and infinite position levers with memory stop for sizes 3 inches and smaller. Hammond 5200 Series or Keystone 122/129

2.10 BALANCING COCK:

- A. Cocks 2" and smaller, square head bronze cocks 125 PSI class with check.

| | | |
|----------------|------------------|------------|
| Hammond IB-123 | Crane 254 | Powell 955 |
| Walworth 554 | Lunkenheimer 454 | |

B. Cocks over 2", lubricated plug valves with semi-steel body 175 PSI class.

| SCREWED 2" AND 3" | FLANGED 4" AND OVER |
|--------------------------|----------------------------|
| Powell F 2200 | Powell F 2201 |
| Walworth 1700 | Walworth 1700F |
| ACF R 1430 | ACF R 1431 |

C. Lubricated plug cocks over 4" shall have a geared or worm drive operator.

PART 3 - EXECUTION

3.01 Install Valves with Operator in horizontal or vertical position; do not install with operator below horizontal position.

END OF SECTION

SECTION 15342 - HVAC CHILLED WATER SYSTEM

PART 1 - GENERAL

1.01 See Sections 15000 for related work in other Sections and Divisions.

1.02 RELATED SECTIONS AND GROUPS:

- A. Section 15302 - Black Steel Piping
- B. Section 15349 - Piping Systems Pressure Testing, Cleaning and Sterilization
- C. Group 15100 - Equipment, Receiving Piping Connections

1.03 ACCEPTABLE PRODUCERS:

- A. Those specified hereinafter.

1.04 SUBMITTALS:

- A. Producer's data sheets for each product.

PART 2 - PRODUCTS

2.01 PIPING:

- A. Schedule 40 black steel with cellular glass insulation system above grade.

2.02 WELDED FITTINGS:

- A. Butt welding type same schedule as pipe. Tube turns, Midwest or Grinnell.

2.03 THREADED FITTINGS:

- A. Black malleable iron 150 lb. class. Grinnell, Stockham or Walworth.

2.04 AUTOMATIC AIR VENTS:

- A. 150 PSIG working pressure. Metraflex MV-15. Crane No. 976, Sarco 13W or Armstrong 1 AV.

2.05 WYE STRAINERS:

- A. Steel piping system strainers - malleable or cast iron, 125 PSIG working pressure. Free area of strainer - not less than 300% cross sectional area of pipe. Strainer mesh, perforation size and pattern as follows:

| Pipe Size | Pattern | Mash or Perforation Diam. |
|---------------|--------------|---------------------------|
| To 2 inches | Threaded WYE | 20 Mesh |
| 2 to 3 inches | Threaded WYE | 0.045 inch diam. |

- B. Provide blow down valve and cap on 1-½" and larger strainers. Use valve not less than ½ strainer blow down outlet size.

PART 3 - EXECUTION

3.01 INSTALLATION:

- A. Unions and Flanges: Install in all connections to equipment installed or provided for under this Division and where required to permit removal of other items requiring maintenance or replacement.
- B. Piping:
1. General: Cut pipe accurately to measurements established at the site; work into place without springing or forcing; and clean all windows, doors and other openings. Ream all piping to remove burrs and install so as to permit free expansion and contraction without causing damage. Make all changes in direction with fittings. Conform to Section 15302 Execution.
 2. Pipe Sizes 3-½ Inch and Larger: Shall be welded. Use welding rings for sizes 4" and larger.
 3. Pipe Sizes 3 Inch and Smaller: Shall be threaded.
 4. Provide sufficient swing joints, expansion loops and devices necessary for a flexible piping system. Install drain valves at all low points of each system to enable complete drainage, and air vents at all high points in the piping system to enable complete air venting.
 5. Pipe all drains from strainers, etc., to spill over an open sight drain, floor drain or other acceptable discharge points, and terminate with a plain end (un-threaded pipe) 6" above the drain. Rigidly support all drains.
 6. Weld-O-Let type fittings may be used for branch take-offs where size of take-off does not exceed 3" and the take-off is at least two standard pipe sizes smaller than the main size. Standard welding trees shall be used in all other locations.
 7. All pipe and fittings with screwed ends shall have its threads cut clean and true in conformance with the USASI Specifications for taper threads. All screwed pipe joints, except where specified otherwise, shall be made up with non-soluble, non-toxic, approved thread compound applied to male threads only.
 8. Connections between pipe, fittings, hangers, and equipment of dissimilar metals shall be avoided wherever practical. Wherever such connections are unavoidable, they shall be insulated against direct contact, using a high grade dielectric insulating material of Teflon, Micarta or neoprene.
 9. Flush and test installed piping in accordance with Section 15349 prior to making connections to equipment and treating water.
 10. Remove strainer screens and open blow down valves during flushing operation. Reinstall screens after system is flushed.

END OF SECTION

SECTION 15349 - PIPING SYSTEMS PRESSURE TESTING, CLEANING & STERILIZATION

PART 1 - GENERAL

1.01 See Sections 15000 for related work in other Sections and Divisions.

1.02 SUBMITTALS:

- A. Those hereinafter specified.

PART 2 - PRODUCTS

NONE SPECIFIED.

PART 3 - EXECUTION

3.01 PRESSURE TESTS - GENERAL:

- A. No piping work, fixtures, or equipment shall be concealed or covered until they have been inspected and approved by the Engineer or his representative, who shall be notified when the work is ready for inspection. All work shall be completely installed, tested as required by this section and local ordinances, and shall be leak-tight before inspection. All tests shall be repeated upon request to the satisfaction of those making the inspection.
- B. Tests shall be applied for a minimum period of four (4) hours after leaks are repaired except for steam/condensate.
- C. Final pressures at the end of test period shall be no more nor less than that caused by expansion or contraction of the test medium due to temperature changes.
- D. Check of systems during application of test pressures should include visual check for water medium leakage, soap bubble or similar for air and nitrogen medium, and halide torch for refrigerant medium after charging.
- E. During heating and cooling cycles, linear expansion shall be checked at all elbows, U bends, expansion joints, etc., for proper clearance.

3.02 PRESSURE TEST PROCEDURES:

| Type of System | Gauge Pressure | Medium |
|--|--|--------|
| (Lbs. Per Square Inch or Vacuum in Inches) | | |
| Soil, Waste, Vent Rain Water Leaders and Storm Drainage Piping Within Building | Minimum of 10' head on each joint for duration of check or 1 hour minimum with no loss in head | Water |
| Compressed Air (High Pressure) | 150% of receiver pressure | Air |
| Compressed Air (Reduced Pressure) | Twice the reduced pressure but not less than 50 psi | Air |
| Domestic Water | Twice normal static pressure at service point | Water |
| Chilled water, steam and condenser, and solar hot water | Twice system operating pressure but not less than 150 psi | Water |
| Fire and Sprinkler Systems | 200 psi | Water |
| Gas | 5 psi | Air |

| Type of System | Gauge Pressure | Medium |
|---|--|---------------|
| (Lbs. Per Square Inch or Vacuum in Inches) | | |
| Fuel Oil | 125 psi for 12 hours 28" Hg. vacuum for 12 hours | Air |
| Vacuum Cleaning System Oxygen, Vacuum & Medical Air | See NFPA-56F Ch. 5 | |

3.03 CLEANING:

- A. Clean chilled water system by flushing and draining three times, at a rate of flow exceeding design rate.
- B. Contractor to coordinate new pipe flushing with UF Facilities Services OE in accordance with UF Design and Construction Standards Section 18500, Item 1.7.A.

END OF SECTION

SECTION 15407 - TESTING AND BALANCING OF MECHANICAL SYSTEMS

PART 1 - GENERAL

1.01 See Sections 15000 for related work in other Sections and Divisions.

1.02 RELATED SECTIONS:

- A. Section 15407 - Testing and Balancing of Mechanical Systems

1.03 QUALIFICATIONS:

- A. Perform this Section's work by an independent test and balance company regularly and exclusively engaged in this type of work. Company to be a member of Associated Air Balance Council, Los Angeles, California or Nebbs. Certify test results by a regular employee of company.

1.04 JOB CONDITIONS:

- A. Perform complete testing and balancing with Engineer's mechanical and electrical inspector in attendance; and be subject to further checking by designing Engineer.
- B. Do not begin air balancing and adjusting until system has been completed and is in full working order. Contractor is to put all heating, ventilating, and air conditioning systems and equipment into full operation and continue their operation during each testing and adjusting working day.
- C. As part of this Contract's work, Mechanical Subcontractor is to make any changes in pulleys, belts, and dampers and/or add additional dampers required for correct balancing.

1.05 SUBMITTALS:

- A. Contractor to submit name of test and balance company for Engineer's approval within thirty (30) days after awarding of contract.
- B. Submit six (6) copies of dated test and balance report upon completion of test and balance work, to Engineer.
- C. Testing and balancing company to submit list of instruments to be used to Engineer.

PART 2 - PRODUCTS

2.01 All instruments used in testing are to be in good condition and to have been calibrated and certified within the previous six (6) months.

2.02 Instruments to be of type normally recognized as adequate and accurate for test contemplated. List type of instrument, manufacturer, serial number and latest calibration date, as part of submitted test data.

PART 3 - EXECUTION

3.01 AIR BALANCING:

- A. Set dampers, volume controls, and fan speeds to obtain specified air delivery with minimum noise level.
- B. Set grille deflections as noted on plans. Modify deflections if required to eliminate drafts or objectionable air movement.
- C. Record air terminal velocity after completion of balance work.

- D. Record final grille and register deflection settings if different from that specified on contract drawings.
- E. Record all fan speeds.
- F. Balance multizone and double duct systems with all air through the cold deck. Recheck for noise level in space at 50% bypass.

3.02 TEMPERATURES (Record Following):

- A. Outside dry and wet bulb temperatures.
- B. Dry bulb temperature in each room and at least one wet bulb temperature in each zone.
- C. Refrigerant liquid and suction temperatures.
- D. Inlet and outlet temperature of each heat exchange device--both fluids.

3.03 PRESSURES (Record Following):

- A. Suction and discharge static pressure of each fan.
- B. Suction and discharge pressure of each pump.
- C. Each refrigerant suction and discharge pressure.
- D. Water pressure drop through each heat exchanger.

3.04 MOTORS AND OTHER APPARATUS (Record Following):

- A. Complete nameplate data for motors, fans, air handling units, chillers, pumps and all other equipment.
- B. Motor data to include horsepower, phase, voltage, RPM, full load nameplate current, fuse rating in disconnect switch, number or manufacturer's size designation, and ampere rating of over-current and low voltage protection devices in starters.

3.05 CONTROLS:

- A. Check all temperature and humidity controllers for location and calibration.
- B. Check operation of all controllers and controlled devices to verify proper action and connection.
- C. Check all motorized face and bypass or zone damper motors for leakage when in closed position. If leakage is more than 5%, Mechanical Subcontractor will reset damper linkages.
- D. Check all valves for tight closure under all operating conditions.

3.06 OBSERVATIONS AND RECOMMENDATIONS:

- A. In event mechanical systems cannot be adjusted to specified quantities or levels of performances, comments and recommendations for corrective steps will be included in the testing and balancing report.
- B. Report to Engineer in writing, deficiencies noted in operation of system, as well as adjustments and recalibration made during change-of-seasons test noted below.

3.07 ADDITIONAL REQUIREMENTS FOR TEST AND BALANCE COMPANY:

- A. Include an extended warranty of ninety (90) days after completion of test and adjust work, during which time Engineer, at his discretion, may request a recheck, or resetting of any outlet, supply air fan, or exhaust fan as listed in test report. Company to provide technicians and instruments and make any tests required by Engineer during this time period.

END OF SECTION

DIVISION 16 / ELECTRICAL - TABLE OF CONTENTS

| Section No. | Description |
|--------------------|--|
| 16000 .. | Electrical, General |
| 16007 .. | Related Divisions and Sections |
| 16100 .. | Basic Materials and Methods |
| 16101 .. | Electrical Identification |
| 16110 .. | Disconnect Switches |
| 16112 .. | Fuses |
| 16120 .. | Molded Case Circuit Breakers & Switches |
| 16730 .. | Fire Detection and Alarm System, Extend Existing System |
| 16900 .. | Work Required for Equipment Furnished in Other Divisions |

SECTION 16000 - ELECTRICAL, GENERAL

PART 1 - GENERAL

1.01 CONTRACT PROVISIONS:

- A. The General Conditions and Supplementary General Conditions of the Project Manual are made a part of this Division of the Specifications and Drawings.
- B. Labor, materials and equipment specified in one of these Sections of the Specifications may apply to other Sections of Division 16.
- C. Review mechanical drawings in order to be aware of conditions affecting the electrical work.
- D. Materials shall be new, approved by Underwriter's Laboratories, and listed for the application specified or indicated.
- E. Installation shall be in accordance with acceptable industry standards except where special procedures are indicated or specified.
- F. Materials shall be by American producers unless specified otherwise.
- G. The term "Provide" is deemed to include labor, materials, equipment and incidentals necessary to furnish and install the items or system indicated, complete and in operating condition.

1.02 FIELD MEASUREMENT AND COORDINATION:

- A. Confirm the field dimensions with drawing dimensions and locations of equipment, to insure fit with other trades' work, and other electrical work in this Division.
- B. Coordinate this Division's work in proper sequence with all other trades, to insure that total work is completed within contract time schedule.
- C. Locate equipment, materials and apparatus symmetrical with architectural elements. In other instances, locations of equipment and piping will be shown on mechanical drawings. Be guided by conditions existing at job, correlating this work with that of others.
- D. Install the work to fit the structure, avoid obstructions and retain clearance, headroom openings, and passageways. Cut no structural members without written approval.
- E. Examine any existing conditions, and premises, and compare drawings with existing conditions. Report any observed discrepancies. Written instructions will be issued to resolve observed discrepancies.

1.03 RELATED DIVISIONS AND SECTIONS:

- A. Comply with the Section "Related Divisions and Sections" which is a part of this Division of the specifications.

1.01 CONNECTING TO THE WORK OF OTHERS:

- A. Prior to starting and during the progress of the work, examine work and materials installed by others as they may apply to this Division's work. Report conditions which will prevent satisfactory installation.
- B. Start of the work will be construed as acceptance of suitability of work of others.

1.02 SINGULAR REFERENCES:

- A. Singular References in this Division's Specifications sections shall not be construed as requiring only one device if multiple devices are shown on drawings.

1.03 CONTRACT DRAWINGS:

- A. Size and location of the equipment is drawn to scale wherever possible. Make use of all contract documents and reviewed shop drawings to verify exact sizes, dimensions and locations.
- B. Drawings indicate locations of fixtures and equipment and convey general intent of work. They are not intended to show minute details of all components.
- C. Where systems components appear on plan drawings and on diagrams, the plan drawing shall be used for determining quantities and general locations.
- D. Drawings and Specifications are diagrammatic and supplementary one to another. An attempt has been made on the drawings to separate and apportion work of the trades, however, such separation and apportionment does not relieve Contractor from full responsibility of compliance with the contract documents. Drawings and specifications intend one complete workable system, correctly installed, ready for service, with all materials and workmanship indicated.
- E. Conflict, discrepancies, interferences and omissions between the drawings and specifications shall be reported prior to bidding. Written clarification will be promptly issued.

1.04 SHOP DRAWINGS & SUBMITTALS:

- A. Submit in accordance with the General Conditions and Supplementary General Conditions of the Project Manual, and in accordance with the specific requirements of Division 16.
- B. Submit for each Section of Division 16 that indicates submittals are required for approval. Include drawings, diagrams, reference materials, material lists, cuts and other data required in a single group and in a single submission for each section. Do not submit partially for any section.
- C. Do not submit products which are not intended for use on this project.
- D. Submittals containing products by unapproved manufacturers will be returned as "Rejected". Other products contained within the same submittals as the unapproved products will not be reviewed.
- E. The term "Per Specification" will not be acceptable.
- F. If any required items are omitted from this submittal, the Owner's representative shall select each item indicating producer, model, etc., and such decision is final.

1.05 REQUEST FOR SUBSTITUTIONS:

- A. Where a particular system, product or material is specified by name, consider it as a standard basis for bidding, and base proposal on particular system, product or material specified.
- B. Request for substitutions on Division 16 equipment shall be submitted to Karen Olitsky, Procurement Agent III, at kolitsk@ufl.edu no later than 1/12/2021 at 5PM. Approval of the alternate products will be by addendum to the specifications or drawings. The listing of acceptable producers does not indicate that the listed producers standard products are acceptable but that they must meet the quality, materials, capacity and performance of the specified products.
- C. Request submittals shall include product data sheets indicating all specification requirements, highlighted and indexed by paragraph number to this specification.

- D. If approved substitution contains differences not indicated in the request, the right is reserved to require equal or similar features to be added to the substituted products, at no additional cost to the owner.

1.06 MODEL NUMBERS:

- A. Catalog numbers and model numbers indicated in the drawings and specifications are used as a guide in the selection of the equipment and are only listed for the contractor's convenience. The contractor shall determine the actual numbers for ordering materials in accordance with the written description of each item and with the intent of the drawings and specification.

1.07 WORKMANSHIP:

- A. Installation of equipment, fixtures and materials shall be made by competent specialists in each trade. The work shall be done in an orderly manner allowing adequate space for servicing valves and equipment. Slipshod or untidy installation of equipment, fixtures or materials will not be accepted. It is the contractor's responsibility to supervise the work with sufficient care to prevent unacceptable workmanship from occurring.

1.08 CONSTRUCTION ELECTRICAL UTILITIES:

- A. Provide all temporary wiring for power, systems, and light required for construction purposes and remove such temporary wiring when use is no longer required.
- B. Provide sufficient temporary lighting to allow optimal worker safety, productivity and workmanship.

1.09 MATERIAL STORAGE AND PROTECTION:

- A. Store and protect all material and equipment to prevent damage and weathering. Refer to the section "General Conditions and Supplementary General Conditions" of this project manual.

1.10 INSTRUCTIONS:

- A. Upon completion of the work, provide a competent and experienced person who is thoroughly familiar with the project for a period of time deemed necessary by the owner to instruct permanent operating personnel in the operation of equipment and control systems.
- B. Install engraved metal or plastic name plates or tags on controls, panels, starters, etc.

1.11 RECORD DRAWINGS:

- A. At the commencement of the work, the General Contractor will be furnished with complete sets of white prints of the Electrical drawings. All corrections, variations and deviations to the drawings, including those required by change orders, if any, must be recorded in colored ink or colored pencil at the end of each working day on these prints which shall be available at all times for observation. Record drawings shall indicate the "as-built" equipment locations and wiring methods of all work. Any variation of raceway and wiring schemes shall be clearly marked. Add locations of all junction boxes, pull boxes, access panels, etc. not shown on contract drawings.
- B. The Contractor shall submit one complete set of these white prints, marked as stated above, indicating the actual completed installation of the electrical work included under this contract.

1.12 ACCEPTANCE:

- A. Complete all work required prior to requesting final job observation. Submit written confirmation that all punch lists issued during construction have been checked and the required work completed.
- B. Test together and separately to determine that:

1. System is free from short circuits and other faults.
 2. Motor starter overload devices are sized correctly.
 3. Motors rotate correctly.
 4. All equipment operates correctly and as specified.
 5. Grounded equipment and outlets have maximum of 25 OHMS resistance to ground.
- C. Make necessary repairs and replace any items of material or equipment or part thereof which has proven defective.
- D. Bind maintenance instructions and parts lists in booklets.
- E. Furnish a complete set of "record" reproducible tracings of the Contractor's work.
- F. Furnish spare materials to Owner's representative. Refer to individual Division 16 Sections for spare materials requirements.
- G. Acceptance will be made on the basis of tests and job observation. A representative of the firm that performed test work shall be in attendance to assist. Furnish the necessary adjustments and assist with final job observation.
- 1.13 CLEAN-UP:
- A. Thoroughly clean all parts of apparatus and equipment of cement, plaster and other materials. Remove all oil and grease spots. Repaint or touch up as required to look like new. Surfaces shall be carefully wiped and all cracks and corners scraped out. Exposed metal work to be brushed down with steel brushes to remove rust and other spots and touched up with primer. During progress of work, the Contractor shall clean up and leave premises and all portions of building free from debris and in a clean and a safe condition.
- 1.14 GUARANTEE AND SERVICE:
- A. The Contractor shall guarantee labor, materials and equipment for a period of one (1) year from Substantial Completion, or from Owner's occupancy, whichever is earlier and shall include all necessary adjustments to and replacement of defective items.
- B. In addition to the guarantee, Contractor shall furnish maintenance for all equipment during the guarantee period.
- C. Owner reserves the right to make emergency repairs to keep equipment in operation without voiding the Guarantee Bond nor relieving the Contractor of his responsibility during guarantee period
- 1.01 ASBESTOS:
- A. No product material, or process containing Asbestos shall be permitted in this Division's work. The cost of removal of any such item shall be at the Contractor's sole expense.

END OF SECTION

SECTION 16007 - RELATED DIVISIONS AND SECTIONS

PART 1 - GENERAL

1.01 The following is a list of the related Divisions of the specifications and the Contractor shall be held responsible for all the requirements therein.

- A. Division 1 - Non-Technical Specifications
- B. Division 15 - Mechanical

1.02 Refer to the Table of Contents or Index for a list of related sections of the specification and the Contractor shall be held responsible for all the requirements therein.

END OF SECTION

SECTION 16100 - BASIC MATERIALS AND METHODS

PART 1 - GENERAL

1.01 COMPLY WITH SECTIONS:

- A. General
- B. Related Divisions and Sections
- C. Electrical Identification

1.02 SUBMITTALS:

- A. Submit the producer's specification sheets and detail drawings for each type of product being provided. Mark each item, feature, and characteristic specified for each product with an identifying mark or arrow. Submit only items intended for actual use.
- B. Submit Fire Stopping Systems specifically identified for each type of penetration occurring for project.

PART 2 - PRODUCTS

2.01 ACCEPTABLE PRODUCERS:

- A. Allied Tube and Conduit; Bridgeport; Ilasco; Raychem; American Insulated Wire Company; Anaconda Industries; Appleton Electric; Arlington Industries; Belden Corporation; W. H. Brady Company; Carlon; Crouse-Hinds Company; Erico; ETP; General Cable Company; General Electric Company; Hoffman Engineering Company; Harvey Hubbell, Inc.; Metacaulk; Midland-Ross Corporation; Okonite Company; O-Z/Gedney; Raco, Inc.; Republic Steel Corporation; 3M; Southwire; Square D Company; Thomas and Betts; Triangle PWC, Inc.; Wheatland Tube Company; Wiremold Company / Walker.

2.02 RACEWAYS:

- A. Intermediate Metal Conduit (NEC Art. 342) shall be galvanized steel, protected inside and outside.
- B. Rigid Steel Conduit (NEC Art. 344) shall be galvanized steel, protected inside and outside.
- C. Electrical Metallic Tubing (NEC Art. 358) shall be steel, protected inside and outside by a coating of approved corrosion-resistant material such as zinc or cadmium.
- D. Flexible Metal Conduit (NEC Art. 348) shall be galvanized steel, protected inside and outside.
- E. Liquid Tight Flexible Metal Conduit (NEC Art. 350) shall be galvanized steel, protected inside and outside and having an extruded outer liquid tight non-metallic sunlight resistant jacket. Use with standard liquid tight fittings.
- F. Wireways (NEC Art. 376) shall be sheet metal troughs with hinged or removable covers. Rust resistant undercoat and gray finish coat. Sizes as indicated or for the number of conductors enclosed. Exterior units shall be weatherproof. Steel shall be minimum 14 gauge.

2.03 RACEWAY FITTINGS:

- A. Intermediate Metal Conduit shall have threaded fittings, galvanized steel or threadless compression galvanized steel or threadless compression cadmium plated malleable iron. Fittings shall be rain tight/concrete tight.
- B. Rigid Steel Conduit shall have threaded fittings, galvanized steel or threadless compression galvanized steel or threadless compression cadmium plated malleable iron. Fittings shall be rain

tight/concrete tight. Box connections shall have plastic bushings to protect wire insulation from metal edges.

- C. Electrical Metallic Tubing fittings shall be steel set-screw type with steel zinc plating; except provide steel compression type for water-tight locations.
- D. Flexible Metal Conduit fittings shall be steel zinc plated or malleable iron cadmium plated with insulated throat and screw type having angular wedge fitting between convolutions of conduit. UL approved types.
- E. Liquid-tight Flexible Metal Conduit fittings shall be steel or malleable iron gland nut cadmium plated, steel bearing washer cadmium plated, nylon or vinyl conduit sealing ring, steel grounding ferrule threaded to engage conduit spiral, cadmium plated, malleable iron body with insulated throat, cadmium plated, nylon or vinyl sealing ring and plated steel locknut, malleable iron locknut 2" and above. Fitting shall be UL approved.
- F. Wireway fittings shall be UL approved, steel, rust resistant undercoat and finish coat to match the wireway. The fittings shall be so designed that the sections can be electrically and mechanically fitted together to form a complete system. Dead ends shall be closed.
- G. Expansion Fittings shall be steel, corrosion protected for metal raceways.
- H. Couplings and Unions shall be galvanized steel, tapered thread standard conduit couplings for intermediate metal conduit and rigid metal conduit. Split couplings shall be UL approved galvanized steel. Unions shall be ground joint type galvanized steel.
- I. Bushings:
 - 1. Steel, zinc plated, threaded or threadless.
 - 2. Steel, zinc plated, threaded or threadless, phenolic insulated, UL temperature rating 150° C.
 - 3. Malleable iron, cadmium plated, threaded or threadless.
 - 4. Malleable iron, cadmium plated, threaded or threadless, phenolic insulated, UL temperature rating 150° C.
 - 5. Phenolic, UL temperature rating 150° C.
 - 6. Steel, zinc plated, malleable iron, cadmium plated, threaded or threadless, non-insulated or insulated with grounding connector or grounding lug.
 - 7. Insulated bushings shall have phenolic insulation molded to the bushing.
- J. Conduit Seals: Galvanized steel, tapered thread for intermediate metal conduit and rigid metal conduit. UL approved with sealing compound and fiber.
- K. Knock-out Closures: Snap-in style, zinc plated steel. Equal to O-Z/Gedney Type KO.

2.04 BOXES:

- A. Junction Boxes: Junction boxes for exposed work shall be conduit bodies for intermediate metal conduit and rigid metal conduit, threaded, malleable iron, cadmium plated with steel zinc pre-galvanized and neoprene cover gaskets. UL approved.
- B. Outlet Boxes: Outlet boxes for exposed work shall be cast metal, cadmium plated or galvanized with appropriate covers for the device and location. Gasketed type covers for weatherproof installation. UL approved.

- C. Fabricated Boxes: Shall be steel with inside and outside surfaces coated with corrosion-resistant paint or weather resistant coating. Covers shall be hinged or screwed with or without gaskets depending on location.

2.05 CABINETS:

- A. Cabinets shall be flush or surface mounted as indicated on the drawings, fabricated of code gauge galvanized steel with turned lip on front. Cover shall be flat steel sheet with hinged door (concealed hinges) and flush catch and lock. Units shall be keyed alike. Cover shall be treated with rust-resistant undercoat and grey baked finish coat.

2.06 CONDUCTORS:

- A. Conductors shall be 98% conductivity copper, medium or soft drawn. Sizes are AWG-MCM. Sizes No. 10 and smaller may be solid unless noted otherwise. Sizes No. 8 and larger shall be stranded. Insulation shall be THWN-2 or THHN, unless noted otherwise; rated 90° C. wet or dry, 600 volts.
- B. Refer to the section "Electrical Identification" for color coding and identification of conductors.
- C. Wire Connectors: Conductors Size No. 18 to No. 6 AWG shall be UL listed pressure type spring connectors 600 volt. Splicer-Reducer pressure connectors for copper to 500 MCM. Rectangular solderless pressure connectors for copper to 1000 MCM. Split bolt copper alloy connectors for copper to 1000 MCM. Compression sleeves for copper conductors to 1000 MCM with the use of high pressure tools.
- D. Wire Pulling Lubricant: UL approved product produced specifically for wire pulling lubrication.

2.08 SLEEVES:

- A. Galvanized sheet metal flanged type or schedule 40 galvanized steel pipe.

2.09 CONCRETE INSERTS:

- A. Galvanized steel with length necessary for the purpose. Minimum 14 gauge. Galvanized hardware.

2.10 SUPPORTS:

- A. Above Grade: Galvanized steel or malleable straps, galvanized steel channels, fittings and hardware, galvanized steel pipe attachments and structure attachments.

2.11 METAL FRAMING SYSTEM:

- A. Steel channel sections shall be rolled from commercial grade steel.
- B. The cross sectional width dimension of the channel shall be a minimum of 1-½ inches. The depth shall be sized to satisfy the load requirements and deflection.
- C. Channels 1-½ inches in depth or greater shall be rolled from Mfg. Std. 12 gauge steel. Channels smaller than 1-½ inches in depth may be Mfg. Std. 14 gauge steel.
- D. Attachment holes shall be factory punched on hole centers equal to the channel cross sectional width dimension and shall be maximum of 9/16 inches diameter.
- E. The finish on steel components shall be electro-galvanizing.

- F. Nuts, bolts, washers, straps, threaded rod and other parts shall be protected with the same finish as the channels.

2.12 FIRE-STOPPING:

- A. Provide UL listed fire-stopping systems approved for each specific type of penetration and of equal fire rating time duration. Submit each system type for approval.
- B. Sealant shall be capable of maintaining an effective barrier against flame, heat, and smoke in compliance with the requirements of ASTM E 814, UL 1479, ASTM E 119, UL 723, ASTM E84 and UL 263.
- C. Fire-stopping systems shall be manufactured by Metacaulk or approved equal.

2.13 PULL WIRE AND PULL ROPE:

- A. Galvanized steel wire, No. 14 AWG minimum size.
- B. Poly cord, 200 lbs. tensile strength, minimum.

2.14 TERMINAL STRIPS:

- A. Sectional barrier type, molded phenolic for use in wiring control panels. Number of terminals and ampacity as indicated. Binding head screw type. Securely fasten within box or enclosure.

2.15 EQUIPMENT BACKBOARDS:

- A. Exterior grade plywood finished one side, 3/4" thickness, finish with fire retardant paint before mounting. Color code grey, unless noted otherwise.

PART 3 - EXECUTION

3.01 GENERAL:

- A. Materials and equipment shall be installed in a neat and workmanlike manner according to the standards of the industry. Materials and equipment installed and not meeting these standards of the industry may be rejected and required to be removed and reinstalled by the Contractor at no additional cost to the Owner.
- B. Contractor is responsible for the safety and conditions of the materials and equipment installed until Owner's beneficial occupancy or acceptance.
- C. Minor location changes from those indicated may be necessary in order that the work shall conform with the building as constructed, to fit work of other trades or rules of authorities having jurisdiction.

3.02 RACEWAYS:

- A. Rigid Steel Conduit (RSC) and Intermediate Metal Conduit (IMC):
 - 1. Provide RSC or IMC for installation where: exposed on exterior; hazardous locations; or as noted.
 - 2. RSC and IMC installed in concrete or wet locations, shall be made water-tight by applying compound to threads and fittings.
 - 3. RSC and IMC stub-ups shall have bonding bushings connected to the grounding system.

B. Electric Metallic Tubing (EMT):

1. Raceways above grade and in concrete slabs above grade shall be electric metallic tubing (EMT) except as otherwise noted in this section and on drawings, and as limited by NEC. Electric metallic tubing (EMT) in concrete shall have concrete tight fittings.
2. Maximum size of EMT shall be 4 inch. Minimum size shall be ½ inch unless noted otherwise.
3. EMT shall not be installed less than 8 inches above slabs on grade.

C. Flexible Metal Conduit:

1. Install in dry locations only; nominal trade size not less than ½ inch or as permitted by "Exceptions" in NEC.
2. Use with UL approved type fittings of steel or malleable iron.
3. Use as a raceway for motors, transformers or other equipment that may be provided with an adjustable mounting or vibration base. Lengths shall not exceed six (6) feet.

D. Liquid-Tight Flexible Metal Conduit:

1. Install in wet locations, in both concealed and exposed work, where required for protection from liquids, vapors or solids.
2. Use with UL approved type fittings of steel or malleable iron.
3. Use as a raceway for motors, transformers or other equipment that may be provided with an adjustable mounting or vibration base.

E. Install raceways straight and plumb. Squarely cut conduit and properly ream to remove all constriction and burrs before making up joints. Job cut threads shall be given a coat of rust resistant paint such as zinc chromate or equal. Paint exposed threads to retard rusting.

F. Arrange for chases, slots, and openings in other building components to allow for electrical installations. **All penetrations through walls not provided for during initial construction will be cut using proper saw and blade. No breaking of walls with "blows" will be allowed.**

G. Conduit may be exposed in equipment rooms, vertical chases, mechanical electrical rooms, other similar spaces not normally habitable or exposed to public view, and where electrical drawings specifically note "exposed conduit".

H. Raceways shall be supported by approved types of galvanized wall brackets, ceiling trapeze pipe hanger, or pipe straps.

I. Cutting of chases is prohibited.

J. Provide fire-stops in all conduits penetrating fire-rated walls and floors.

K. Provide cable supports in vertical raceways as required by NEC.

L. Conduit shall be closed during construction to prevent entrance of foreign material. Contractor is responsible for the full cost of replacing any conduit rendered unusable by entrance of foreign material.

M. Wireways and wireway fittings shall be used for exposed work and when installed outdoors or in wet locations shall be approved rain-tight construction. Wireways and wireway fittings shall be of a size as indicated.

- N. Expansion fittings shall be provided for raceways to compensate for thermal expansion and contraction and at building expansion joints. Bonding jumpers shall be provided for electrical continuity of the raceway system at the expansion fittings.
- O. Bushings shall be provided at the end of a conduit to protect the insulation of the conductor. Provide grounding bushings for metal raceways, boxes, cabinets to insure that all metallic surfaces are effectively grounded. Metallic raceway may be bonded to cabinets, boxes and panelboards by double locknut and bushing to ensure the metallic parts are all effectively grounded.
- P. Conduit or raceways through which moisture may enter and contact energized live parts shall be sealed or plugged at either or both ends with conduit seals where portions of an interior raceway system are exposed to widely different temperatures, e.g., circulation of air from a warmer to a cooler section through the raceway shall be prevented by conduit seals.
- Q. Install pull boxes in conduit at intervals of 200 feet or less.

3.01 BOXES:

- A. General: Support to concrete form-work, or to other surrounding building material. Provide additional junction and pull boxes where injury to insulation or deformation of wire would occur due to excessive pulling resistance. When several feeders pass through a common pull box, tag each feeder separately, indicating electrical characteristic wire and destination. Protect boxes during construction to prevent entrance of foreign material.

3.01 WIRING:

- A. General: Install all conductors in raceway with grounding conductors. Grounding conductors shall be used in all raceway types. Conductors shall not be installed until conduit system is complete. Bending radius of insulated wire or cable shall not be less than the minimum recommended by producer. Maximum pulling tension of any wire or cable shall not exceed producer's recommended values. Do not injure insulation while installing wire in conduits.
- B. Conductors in Parallel: Conductors connected in parallel (electrically joined at both ends to form a single conductor) shall be of the same length, of the same conductor material, the same circular-mil area, the same insulation type and terminate in the same manner. Where installed in separate raceways or cables, the raceways or cables shall have the same physical characteristics.
- C. Power Circuits: Make connection to motors or equipment.
- D. Wiring in motor control, switchboards, panelboards, junction cabinets, etc., shall be neatly formed, to present a neat and orderly appearance.
- E. Provide separate neutrals for lighting and receptacle branch circuits.
- F. Except for control wiring, the minimum size of wire shall be No. 12 AWG, copper.
- G. Interconnections of control wiring shall be on identified numbered terminal strips.
- H. Splices: Permitted in above grade junction boxes, outlet boxes or other permanently accessible locations. Conductors No. 6 or smaller; provide with devices approved by Underwriters' Laboratories, Inc., as splicing connectors. Splices in conductors larger than No. 6; provide devices approved by Underwriters' Laboratories, Inc., as pressure cable connectors.
- I. The continuity of the ground, neutral, and hot circuits shall not be interrupted by the removal of any device or fixture or equipment. Conductors spliced or pulled straight through boxes shall have minimum of six (6) inches of free conductor measured from outside of box. Conductors pull straight through boxes shall count as two (2) wires for box fill.

3.02 WIRE PULLING LUBRICATION:

- A. Shall be used when any wire is pulled by mechanical means. Wire and cable shall be carefully handled during installation. Wire with any portion of insulation damaged shall have complete pull replaced.

3.03 ELECTRICAL EQUIPMENT CONNECTIONS:

- A. All electrically operated equipment shall have a disconnecting means as required by NEC. Provide disconnecting means at each connection where disconnect is not furnished by equipment supplier.

3.04 SLEEVES, INSERTS AND SUPPORTS:

- A. Equipment Supports: Concrete bases and structural steel to support this Division's equipment and raceways by Contractor whose equipment or raceways is to be supported. Provide a raised reinforced 4" concrete base for all floor supported equipment, or as indicated.
- B. Responsibility: Contractor has the responsibility for furnishing and setting all sleeves, inserts and supports required for his work.
- C. Setting in Concrete: Place all items in concrete forms prior to time concrete is poured. If additional inserts are required in existing concrete work, use self-drilling screw anchors.
- D. Support Spacing: Comply with codes and regulations referenced hereinbefore and as follows:
 - 1. Support no electrical work from piping, ductwork, etc. Where metal decking is used, provide supports independent of decking so that loads will not be transferred to decking. Drill through decking and secure supports to concrete slab.
 - 2. Vertical conduit inside building shall be supported at each floor level and at 10'0" intervals.

3.05 CAULKING AND SEALS:

- A. Openings around penetrations of all electrical raceways and equipment through building floor, wall, ceiling and roof surfaces shall be fire stopped using approved methods.

3.06 PAINTING:

- A. Painting for Division 16 work provided by Division 16 contractor.
- B. Hangers, supports, structural steel and equipment that are not factory finished shall be prime coated and finished coated of color to match the area in which located.
- C. Equipment that is factory finished and has damaged finish shall be touched up to match the factory finish.
- D. All surfaces that are to be painted shall be free of rust, scale, oil and grease before prime coat is applied.
- E. Fire protection equipment shall be finished in Red.
- F. DO NOT paint over nameplates, name tags or labels.

3.07 GROUNDING:

- A. Provide an equipment grounding conductor which shall be separate from the electrical system neutral conductor. The equipment grounding conductor shall be colored green. It shall be continuous from a connection at the Service Entrance Equipment Ground to all switchboards,

distribution and branch panelboards. Equipment grounding conductors shall be provided in all branch circuits serving convenience outlets, receptacles, portable and permanently installed electrical appliances, equipment apparatus and other miscellaneous metal enclosing bodies including light switch boxes normally within contact of personnel. Branch circuit grounding conductors shall be sized in accordance with the National Electrical Code. Connections at panelboards, outlets, equipment and apparatus shall be made in an approved and permanent manner. Resistance to ground shall not exceed 25 ohms.

- B. Bond bushings of the raceway system to ground lugs in boxes, cabinets, motors and equipment to assure electrical continuity of all metallic components of the electrical systems. Comply with the requirements of NEC Articles 250D, 250E, 250F, 250G, 250J and 250K.

3.08 EQUIPMENT BACKBOARDS:

- A. Locate where indicated on the drawings. Install straight and plumb. Secure to structure using screws, toggle bolts or masonry anchors. DO NOT use plastic or wood plugs in masonry or concrete. Do not install combustible backboards in air handling space, plenums or where prohibited by the local governing authority.

3.09 TESTING:

- A. At the completion of the installation of the conductors or cables into the raceway systems, tests shall be conducted by "megger" to ascertain that the insulation for the conductors or cables has not been damaged. Megger test each feeder and branch circuit conductor or cable with an instrument capable of producing approximately 500 volts for conductors or cables insulated with 600 volt insulation.
- B. The insulation resistance of a conductor or cable can be estimated by the formula:

Insulation Resistance (IR) - $K \log D/d$

Where K = specific insulation resistance in megohms-1000 ft at 60° F.

D = diameter over insulation

d = diameter under insulation

IR is inversely proportioned to the conductor or cable length so that a 500 ft. length will have twice the resistance of 1000 ft and a 2000 ft. length will have one-half the resistance of 1000 ft.

Typical Values of K:

| | | |
|--|---|--------|
| Synthetic Rubber, Heat and Moisture resisting 75° C. | - | 2,000 |
| EP Insulation | - | 20,000 |
| Polyethylene | - | 50,000 |
| PVC | - | 2,000 |
| Cross linked polyethylene | - | 20,000 |

- C. The minimum insulation resistance shall be 100 megohms per 1000 feet of 500 mcm conductors or smaller insulated with THW or THWN, and 1,000 megohms per 1,000 feet of 500 mcm conductors or smaller insulated with XHHW or other cross-linked insulation.
- D. Complete records of test data shall be kept on site and made available to Engineer upon request.

END OF SECTION

SECTION 16101 - ELECTRICAL IDENTIFICATION

PART 1 - GENERAL

1.01 COMPLY WITH SECTIONS:

- A. General.
- B. Related Divisions and Sections.

1.02 SCOPE OF WORK:

- A. Contractor shall provide permanent, clear, concise, and uniform identification of all electrical products to ensure the safety, intelligibility and maintainability of each system. See UF Design & Construction Standards for additional electrical identification requirements.

1.03 SUBMITTALS:

- A. Submit the producer's standard descriptive data sheets for each type of product being provided. Mark the data sheet for the specific product being provided with an identifying mark or arrow.

PART 2 - PRODUCTS

2.05 ACCEPTABLE PRODUCERS:

- A. Brady, Burndy, Panduit, Pass & Seymour, Scotch 3M, Seton Nameplate and Thomas & Betts.

2.06 NAMEPLATES:

- A. Type: Engraved laminated plastic.
- B. Size: Character height shall be sized according to equipment size and location with the following general guidelines: (Overall dimensions of nameplate shall be determined by extent of identification characters.)
 - 1. 1" Height: Switchboards, motor control centers, distribution panelboards, transformers, and other large enclosures.
 - 2. ½" Height: Branch circuit panelboards, cabinets, motor starters, disconnects, contactors, relays, pull-boxes, and similar size enclosures.
 - 3. ¼" Height: Switch plates, receptacles, controls, and other small enclosures.

2.07 ADHESIVE LABELS:

- A. Type: Vinyl cloth adhesive labels.
- B. Size: Size according to equipment size and nameplate guidelines listed above. On conduits use 1" high labels for up to 1-¼" trade size and 2" high labels for conduits greater than 1-¼" trade size.
- C. Use:
 - 1. Voltage Characteristic Labels: Provide on all electrical equipment, enclosures, and raceways with system voltage greater than 100 volts. Spacing on raceways shall be at 10 feet intervals and on covers of all associated junction boxes.

2. Warning Labels: Provide label reading DANGER HIGH VOLTAGE on all electrical power enclosures located outdoors or where accessible to unauthorized personnel.

2.08 WARNING SIGNS:

- A. Provide DANGER - DO NOT OPERATE safety tags on all energized equipment where, unauthorized use represents a personal safety hazard equipment damage risk. Contractor shall be responsible for safety of electrical work throughout construction period.

2.09 CONDUIT AND BOX MARKING:

1. Paint conduit and boxes as noted below:

Fire Alarm - Fire Truck Red.

2.10 POWER AND LIGHTING BOX MARKING:

- A. Box covers shall remain unpainted and be marked with load description and panel source and circuits contained within. Printed label 3/4" high per UF standards.

2.11 CONDUCTOR COLOR CODING:

- A. Identification of conductors shall follow the colors set forth herein for the electrical characteristics as indicated:

1. 120 / 208 Volt Three Phase 4 Wire WYE Service

| | |
|---------------------|-------|
| Neutral | White |
| Phase A | Black |
| Phase B | Red |
| Phase C | Blue |
| Grounding Conductor | Green |

2. 277 / 480 Volt Three Phase 4 Wire WYE Service

| | |
|---------------------|--------|
| Neutral | Gray |
| Phase A | Brown |
| Phase B | Orange |
| Phase C | Yellow |
| Grounding Conductor | Green |

- B. Conductors of Size No. 6 AWG and smaller shall have continuous color coded insulation. Conductors larger than No. 6 shall have continuous color coded insulation or be permanently marked by color coded tape/band - 2" minimum width - at all terminations/splices.
- C. Switch leg conductors shall be the color of the phase conductor serving that equipment.
- D. White colored insulation or markings shall be used only for neutral conductors.
- E. Green colored insulation or markings shall be used only for grounding conductors.
- F. The identification of terminals to which a neutral conductor is connected shall be substantially white in color. The identification of terminals to which a grounding conductor is connected shall be substantially green in color. The identification of other terminals shall be a readily distinguishable different color.

- G. Fire Alarm Conductors: Match Existing System Color Code

2.12 CONDUCTOR CIRCUIT MARKING:

- A. Conductors shall be identified by circuit number at all terminations and splices, and within all junction boxes and pull-boxes. Identification shall be by typed legend markers with heat-shrink protective covering - Raychem TMS System; or by numbered snap-on plastic markers for sizes 10 AWG and smaller - Pass & Seymour CAB-3 System. Plastic marker color shall match conductor insulation color.
- B. The same marking method shall be used for all conductors of a given system.
- C. Where more than one neutral conductor is present in a raceway each neutral shall be marked by the circuit number of its associated phase conductor.
- D. Conductor markers may be omitted where conductors are terminated onto numbered terminals.
- E. Conductors routed through cable trays, wireways, floor trench, etc. shall be organized into groups according to system, function, or area served; groups shall be bundled and identified using cable ties with legend markers on 10 foot intervals. Secure cable ties to raceway.

2.13 POWER RECEPTACLE AND LIGHTING SWITCH MARKING:

- A. Each receptacle and lighting switch shall be marked by circuit number using numbered vinyl cloth adhesive markers; ¼" minimum height. Locate marker behind device coverplate but on front of device so it can be readily identified without removal of the device. Thomas and Betts E-Z Code Markers.

2.14 SWITCH COVERPLATE MARKING:

- A. Provide load identification nameplates on switch coverplates for the following conditions:
 - 1. Switch controls load other than general lighting.
 - 2. Separately switched fixture types/groups controlled at common location.
 - 3. Load controlled is not obvious or is remotely located.

2.15 PUSHBUTTONS, CONTROL DEVICES AND PILOT LIGHTS:

- A. Identify with nameplate describing control function / purpose.

2.16 WORKING SPACE FLOOR MARKINGS:

- A. Areas that pertain to Section 110-26 of NEC shall have yellow striping installed diagonally with stripes being three inches (3") wide and three inches (3") apart. The center of the area shall have the words "Safety Zone" installed with letters at least four inches (4") high.

PART 3 - EXECUTION

3.01 GENERAL:

- A. Review and comply with specific identification requirements of products specified elsewhere in Div. 16 and UF design and construction standards.
- B. Power conductor markers shall match associated circuit breaker number.

MP04488 UF Fine Arts "D" Building No. 0269 Replace AHU-1

- C. System conductors markers shall match circuit assignments given in system wiring diagram submittals and shall be consistent with terminal designations.
- D. Box covers shall be painted prior to installation. Paint over-spray will not be acceptable.
- E. All work shall be performed in a neat manner with quality workmanship.
- F. Protect identification from being covered by room finish paint. Any identification obscured to any degree shall be replaced at no additional cost to Owner.
- G. Covers to cabinets, enclosures, boxes, etc. shall be removed during inspection to permit review of conductor identification.
- H. Accurately locate and identify enclosures, pull-boxes, junction boxes, etc. on as-built drawings.

END OF SECTION

SECTION 16110 - DISCONNECT SWITCHES

PART 1 - GENERAL

1.01 COMPLY WITH SECTIONS:

- A. General
- B. Related Divisions and Sections
- C. Fuses

1.02 SUBMITTALS:

- A. Submit the producers product specification sheets and detail drawings for each type of product being provided. Mark the data sheet for the product being provided with an identifying mark or arrow.

PART 2 - PRODUCTS

2.01 ACCEPTABLE PRODUCERS:

- A. Square D, General Electric, Siemens I.T.E. and Cutler Hammer.

2.02 GENERAL:

- A. Provide NEMA Heavy Duty Type H.D., Underwriters Laboratories listed safety switches of voltage, amperes and number of poles as indicated. Label for Service Entrance use where indicated.

2.03 MECHANISM:

- A. Shall be quick make, quick break. Switches shall have a dual interlock to prevent opening of door when switch is in "ON" position or closing of switch when door is in "OPEN" position.

2.04 SWITCH INTERIOR:

- A. Shall have switch blades which are fully visible in OFF position when door is open. Switches shall be of dead front construction with permanently attached arc suppressors hinged or otherwise attached to permit easy access to line-side lugs, without removal of arc suppressor. Lugs shall be UL listed for copper conductors and front removable. All current carrying parts shall be plated by electrolytic processes. Provide ground lug in each switch for grounding conductor.

2.05 ENCLOSURES:

- A. Use NEMA 3R enclosures for all exterior locations and interior locations in wet or humid areas. Use NEMA 1 enclosures elsewhere, except as noted otherwise. Furnish NEMA 1 switches with knockouts. Enclosures for NEMA 1 switches shall be code gauge (UL 98) sheet steel with rust inhibiting phosphate treatment and baked enamel finish. NEMA 3R enclosures shall be of code gauge (UL 98) galvanized steel with rust inhibiting phosphate and baked enamel finish.

2.06 RATINGS:

- A. Safety switches shall be horsepower rated for AC or DC as specified. All fusible switches rated 100 through 600 amperes at 240 volts, and 30 through 600 amperes at 600 volts, shall have the capability of field conversion from standard Class H fuse spacing to Class J fuse spacing without affecting the UL listing. The switch also must accept Class R fuses and have field installable UL listed rejection feature to reject all fuses except Class R. UL listed short circuit ratings, when equipped with Class J or Class R fuses shall be 200,000 ampere RMS symmetrical. 800 and 1200 ampere switches shall have provisions for Class L fuses.

2.07 FUSES:

- A. Provide where indicated and sizes as shown on the drawings. See Section "Fuses".

PART 3 - EXECUTION

3.01 GENERAL:

- A. Provide unfused or fused switch as indicated on the drawings at each motor which is out of sight of its controller or fifty or more feet away from the controller.
- B. Do not stack switches to touch each other, either horizontal or vertically. Allow space between enclosures.
- C. Orient switch enclosures in a vertical position to allow normal movement of hand operators and door hinges.
- D. Switch symbols on electric drawings do not indicate exact switch locations. Locate switches adjacent to motor or equipment unless shown otherwise. Installation shall provide required clear work space.
- E. Clean and touch-up paint on safety switches damaged or scratched during installation.

3.02 IDENTIFICATION:

- A. Affix nameplates to switches to identify equipment served, source panel, circuit number and voltage.

3.03 TESTING:

- A. After all wiring, switches and equipment are in place, carefully test together and separately to determine that:
 - 1. System is free from short circuits and other faults.
 - 2. All equipment operates correctly and as specified.
 - 3. Grounded equipment has maximum of 25 ohms resistance to ground.

END OF SECTION

SECTION 16112 - FUSES

PART 1 - GENERAL

1.01 COMPLY WITH SECTIONS:

- A. General
- B. Related Divisions and Sections

1.02 SUBMITTALS:

- A. Submit the producers product specification sheets and detail drawings for each type of product being provided. Mark the data sheet for the product being provided with an identifying mark or arrow.

PART 2 - PRODUCTS

2.01 ACCEPTABLE PRODUCERS:

- A. Littlefuse, Inc. or Ferraz Shawmut.

2.02 GENERAL:

- A. Products listed herein are common to various Divisions and Specification sections for this project and as shown on the project's drawings.

2.03 Fuses furnished shall be by the same producer.

2.04 VOLTAGE RATING:

- A. Provide 600 volt fuses for 277/480 volt systems.
- B. Provide 250 volt fuses for 120, 208 and 240 volt systems.

2.05 AMPERE RATINGS:

- A. Provide fuses for ampere ratings as indicated.

2.06 INTERRUPTING RATINGS:

- A. Provide fuses with interrupting ratings as indicated.

2.07 MOTOR LOADS:

- A. Fuses utilized in circuits serving motors shall be Class RK5 time delay type with condition indicator - Littlefuse IDSR Series.

2.01 REJECTION FUSE CLIPS:

- A. Provide fuse with rejection feature for switches as indicated.

2.02 CLASS OF FUSES - GENERAL:

- A. Provide fuses of Class J, K, L or R. Class H fuses shall be provided only if indicated.

PART 3 - EXECUTION

MP04488 UF Fine Arts "D" Building No. 0269 Replace AHU-1

- 3.01 Coordinate fuse type and ampacity with fuse holder of safety switch and motor starter.
- 3.02 Equipment circuit fuse ratings indicated on drawings are for "basis of design" equipment. Prior to ordering fuses Contractor shall verify exact fuse ratings with equipment nameplate and / or submittal data and provide ratings as recommended by fuse manufacturer and as required by code.
- 3.03 SPARE FUSES:
- A. Provide one set of fuses of each type and ampacity for spares. 1 for 1-pole circuits, 2 for 2-pole circuits and 3 for 3-pole circuits. Voltage to correspond with circuit to be protected.
- 3.04 TESTING:
- A. Verify fuse ratings match equipment requirements.
 - B. Verify fuses are properly installed with disconnect switches and fuse blocks.

END OF SECTION

SECTION 16120 - MOLDED CASE CIRCUIT BREAKERS & SWITCHES

PART 1 - GENERAL

1.01 COMPLY WITH SECTIONS:

- A. General.
- B. Related Divisions and Sections.

1.02 SUBMITTALS:

- A. Submit the producer's standard descriptive data sheets for each type of product being provided. Mark the data sheet for the product being provided with an identifying mark or arrow.

PART 2 - PRODUCTS

2.01 ACCEPTABLE PRODUCERS:

- A. Products furnished shall be by same producer as Panelboard.

2.02 GENERAL:

- A. Match existing branch circuit breakers in existing panelboard.

2.03 MOLDED CASE CIRCUIT BREAKERS:

A. General:

1. Match existing circuit breakers Ampere Interrupting Capability (AIC)
2. Individual circuit breakers shall be safety dead front units in NEMA type enclosure.
3. Molded case circuit breakers shall have over-center, trip free, toggle-type operating mechanisms with quick-make, quick-break action and positive handle indication.
4. Two and three pole circuit breakers shall have a common trip.
5. Circuit breaker operating handle shall assume a center position when tripped.
6. Circuit breakers shall be calibrated for operation in an ambient temperature of 40 degrees C.
7. Circuit breakers shall be constructed using glass reinforced polyester insulating material providing superior dielectric strength. Current carry components shall be completely isolated from the handle and the accessory mounting area.
8. Circuit breakers shall be factory sealed and shall have a date code on the face of the circuit breaker. Poles shall be labeled with respective phase designations.
9. Breaker faceplate shall indicate rated ampacity. Breaker faceplate shall indicate UL and IEC certification standards with applicable voltage systems and corresponding AIC ratings.
10. Circuit breaker handle accessories shall provide provisions for locking handle in the "ON" or "OFF" position.
11. Provide molded case circuit breakers with options and features as indicated.

- B. Thermal Magnetic Type: Each circuit breaker shall have a permanent trip unit containing individual thermal and magnetic trip elements in each pole.

2.01 MOLDED CASE SWITCHES:

- A. Circuit breaker style molded case dead front construction interchangeable with circuit breakers of same ampere frame size.
- B. Automatic factory preset magnetic trip point calibrated solely to protect the switch itself - not intended for over-current protection of branch circuits or feeders.
- C. Accepts same lugs and accessories as molded case circuit breakers of same ampere frame size.

2.02 MOLDED CASE BREAKER & SWITCH ENCLOSURES:

- A. Enclosures for individually mounted breakers and switches shall be NEMA type with factory finish baked enamel.
- B. NEMA 1 enclosures shall be furnished with knockouts and fabricated of steel in accordance with UL 98 and UL listed
- C. Provide enclosure with ground bus or terminal and full insulated neutral bar or terminals.

PART 3 - EXECUTION

3.01 Provide the circuit breakers and switches specified on the Drawings.

3.02 Circuit breakers and switches shall be suitable for mounting and operating in any position. Unless noted otherwise, separately mounted units shall be vertically oriented to allow normal up/down movement of handles.

3.03 Coordinate unit locations to allow required work clearances and accessibil

3.04 IDENTIFICATION:

- A. Units mounted in separate enclosures shall have cover mounted nameplate to identify source and load. Units mounted in panelboards shall be identified by circuit number and corresponding typed description on circuit directory.

3.04 ADJUSTMENTS:

3.01 TESTING:

- A. After installation is complete perform tests to determine that:
 - 1. System is free of short circuits and other faults.
 - 2. All equipment operate correctly and as specified.
 - 3. Grounded equipment has maximum of 25 ohms resistance to ground.

END OF SECTION

SECTION 16730 - FIRE DETECTION AND ALARM SYSTEM, EXTEND EXISTING SYSTEM

PART 1 - GENERAL

1.01 COMPLY WITH SECTIONS:

- A. General
- B. Related Divisions and Sections

1.02 SUBMITTALS:

- A. Submit the producers standard descriptive data sheets for each type of product being provided. Mark the data sheet for the product being provided with an identifying mark or arrow.
- B. Submit a "point to point" wiring diagram with the connections to the equipment and terminal cabinets. Indicate the equipment numbers, terminal numbers, wire numbers, zone numbers and wire colors. Include the connections for the Mechanical Systems and the Fire Detection and Alarm System. The submittal shall be made for approval prior to the installation of the wiring in the raceways.

1.03 SYSTEM DESCRIPTION:

- A. The existing system is a electrically supervised, manual and automatic activated, direct current powered system with batteries, battery charger, alarm horns and flashing visual alarm lights, and alarm, and recall capability. Provide additions to the system as shown on the drawings.

PART 2 - PRODUCTS

2.01 GENERAL:

- A. Equipment and materials shall comply with the current applicable codes and standards of the Underwriters Laboratories, Inc., ANSI, NEMA and NFPA and shall be listed, approved and labeled for the applications. Build, test and ship the total system components by the same producer, except as noted, providing a single source or responsibility.

2.02 ACCEPTABLE PRODUCERS:

- A. Match Existing

2.03 SMOKE DETECTORS - AIR DUCT MOUNTED:

- A. Air duct type housing, sampling and reference tube kits, visual LED alarm indicator, Match existing.

2.04 REMOTE MOUNTED DUCT SMOKE DETECTOR TEST STATION:

- A. Red LED mounted on a single gang Type 302 stainless steel plate. Match existing.

2.05 FIRE ALARM CONTROL PANEL:

- A. EST QS1 Series - Existing. Provide new components to accommodate new devices as required. Provide new wiring per manufacturers recommendations, match existing color code.

2.06 AUDIBLE/VISUAL SIGNAL APPLIANCES:

- A. Shall be combination modular horn and lamp assembly, red lens with the word "FIRE" imprinted in white. Horns and housing shall be red in color. Match existing.

2.07 VISUAL SIGNAL APPLIANCES:

- A. Match existing.

2.08 WIRING:

- A. Conductors to connect the equipment and materials for the Fire Alarm System shall be type THWN or THW insulated copper conductors rated for 600 volts. Match existing color code. Wire size shall be as recommended by the Fire Alarm manufacturer with minimum size #14 AWG.

2.09 MATERIALS AND METHODS:

- A. Refer to and comply with the Division 16 Section "Basic Materials and Methods".

PART 3 - EXECUTION

3.01 WIRING:

- A. Shall be in metallic conduit solely for the fire detection and alarm system. Minimum conductor size #14 AWG. Install and connect in conformance with the producers recommendations and wiring diagrams.
- B. All wiring shall be identified by being tagged, numbered, color coded and terminated on terminal blocks in the cabinets, in boxes, at equipment and at devices. Wire nuts or splices are not permitted. Each set of zone conductors shall be tagged with the zone number on each conductor at termination (each end) and in each junction or pull box in the raceway system.

3.02 Junction Boxes and Cabinets for this system, shall be painted "FIRE TRUCK RED".

3.03 Identify System additions on a site zone diagram posted at the fire alarm control panel.

3.04 Provide Remote LED Alarm Indicators for duct smoke detectors as indicated on drawings.

3.05 Air Duct Smoke Detectors, including housing and sampling tubes where used, shall be listed or approved for the range of air velocities which may exist in service.

3.06 Air Duct Smoke Detectors shall be suitable for the maximum temperature which may exist in service.

3.07 TESTS:

- A. Check each audible and visual alarm for function.
- B. Activate each smoke detector and check for function.
- C. Repeat tests 3.12-A and 3.12-B with "NORMAL" power disconnected.
- D. Perform tests in the presence of Owner's representative.

END OF SECTION

SECTION 16900 - WORK REQUIRED FOR EQUIPMENT FURNISHED IN OTHER DIVISIONS

PART 1 - GENERAL

1.01 COMPLY WITH SECTIONS:

- A. Electrical / General
- B. Related Divisions and Sections
- C. Basic Materials and Methods.
- D. Electrical Identification.

1.02 SUBMITTALS:

- A. Review submittals of equipment furnished by others to coordinate electrical requirements.
- B. Verify equipment branch circuit ratings prior to ordering.
- C. Establish equipment dimensions and connection details in a timely manner to provide suitable electrical rough-in.
- D. Notify Engineer in writing of any deviations requiring revisions to the electrical work.

PART 2 - PRODUCTS

- 2.01 Refer to the section "Related Divisions and Sections" for equipment that is furnished in other Divisions of the Project Manual.
- 2.02 Furnish electrical products compliant with applicable sections of Division 16 required for installation of equipment.

PART 3 - EXECUTION

- 3.01 Provide over-current protection, disconnects, starters, raceway, boxes, fittings, devices and conductors as required for the electrical services to equipment furnished and installed in the other Divisions.
- 3.02 Make all electrical connections for the equipment furnished and installed in other Divisions. Comply with equipment producers installation instructions, details, and diagrams.
- 3.03 Install electrical accessories and control devices furnished with the equipment. Provide appropriate rough-in and wiring for devices located remote from the equipment.
- 3.04 CORD-AND-PLUG CONNECTED EQUIPMENT:
 - A. Provide receptacles matching plugs furnished with equipment.
 - B. Provide complete cord-and-plug assemblies, in addition to matching receptacle, installed to equipment furnished without such.
- 3.05 FUSE AND OVER-LOAD SELECTION:
 - A. Select disconnect fuse ratings and motor starter overload ratings based upon actual nameplate data of equipment being installed, and applicable requirements of the NEC
- 3.06 TESTING:

- A. After wiring, starters, switches and equipment are in place, test together and separately to determine that:
1. System is free from short circuits and other faults.
 2. Motor starter overload devices are sized correctly.
 3. Motors rotate correctly.
 4. Equipment operates correctly and as specified.
 5. Grounded equipment has maximum of 25 ohms resistance to ground.
 6. Circuits are correctly identified and recorded at directory of supply panelboard / source.

END OF SECTION

UF FINE ARTS "D" - BUILDING No. 0269 REPLACE AIR HANDLING UNIT AHU-1 UNIVERSITY OF FLORIDA - GAINESVILLE, FLORIDA MINOR PROJECT No. MP04488

PREPARED FOR THE UNIVERSITY OF FLORIDA

| ELECTRIC LOAD SUMMARY TABLE | |
|--|------------|
| REMOVED LOAD | - 27722 VA |
| ADDED LOAD | + 77516 VA |
| NET ADDED LOAD | + 49794 VA |
| $\frac{49794 \text{ VA}}{480\text{V} \times 1.73} = 60.0 \text{ AMPS}$ | |
| NET ADDITION OF 60.0 AMPS AT 480V., 3Ø | |

| CHILLED WATER LOAD SUMMARY TABLE | |
|----------------------------------|----|
| EXISTING CHILLED WATER TONS | 61 |
| NEW CHILLED WATER TONS | 61 |
| ADDED CHILLED WATER TONS | 0 |

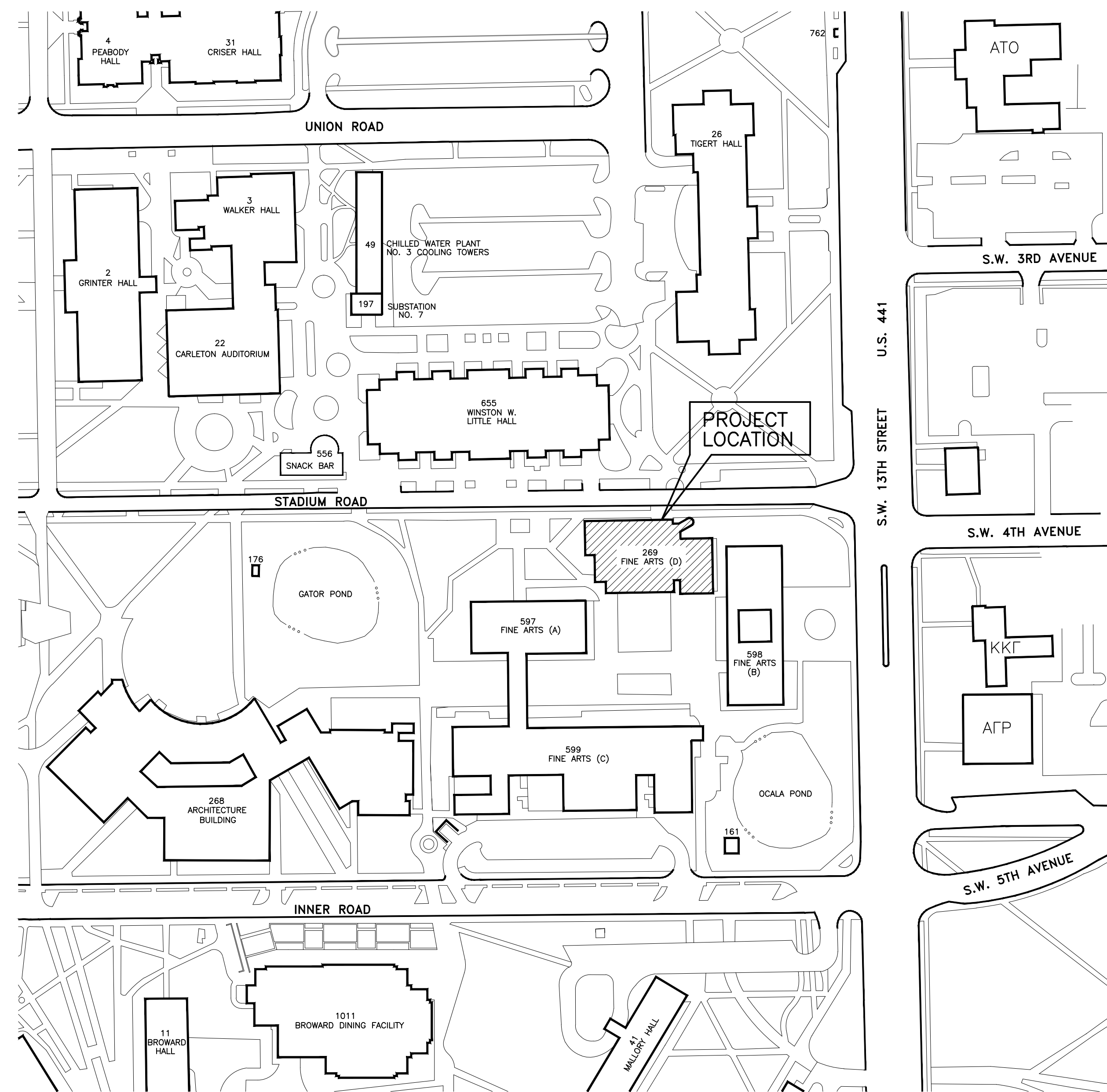

PROJECT DATA

OWNER: UNIVERSITY OF FLORIDA
 PLANNING, DESIGN AND CONSTRUCTION
 232 STADIUM ROAD
 P.O. BOX 115050
 GAINESVILLE, FL., 32611-5050
 (352) 273-4000

PROJECT MANAGER: GREGORY DOYAL ROBERTS
 352-294-3574

ENGINEER: CADWALLADER AND ASSOCIATES, INC
 4000 SW 35TH TERRACE, SUITE D
 GAINESVILLE, FL., 32608
 (352) 376-0520

SHEET INDEX

- CS COVER SHEET.
- M-1 MECHANICAL LEGEND, GENERAL NOTES, SCHEDULES AND DETAILS.
- M-2 MECHANICAL DETAILS, DIAGRAMS AND CONTROL SCHEDULE.
- M-3 FIRST FLOOR HVAC PLAN.
- M-4 SECOND FLOOR HVAC PLAN.
- M-5 THIRD FLOOR HVAC PLAN.
- M-6 THIRD FLOOR MECHANICAL ROOM 334 HVAC 1/4" SCALE PLANS.
- E-1 ELECTRICAL LEGEND, GENERAL NOTES AND DETAILS.
- E-2 PARTIAL FIRST FLOOR ELECTRICAL PLAN AND ONE-LINE DIAGRAM.
- E-3 PARTIAL THIRD FLOOR ELECTRICAL PLANS.

THE UNDERSIGNED ENGINEER DOES HEREBY CERTIFY THAT THE DESIGN OF THIS PROJECT ALONG WITH THE PREPARATION OF ALL CONSTRUCTION DOCUMENTS FOR THIS PROJECT ARE IN COMPLETE CONFORMANCE WITH UNIVERSITY OF FLORIDA DESIGN AND CONSTRUCTION STANDARDS.

CADWALLADER AND ASSOCIATES INC., CONSULTING ENGINEERS
M. Stephen Cadwallader, P.E. 12/9/20
 M. STEPHEN CADWALLADER, P.E. DATE

LOCATION MAP

NOT TO SCALE

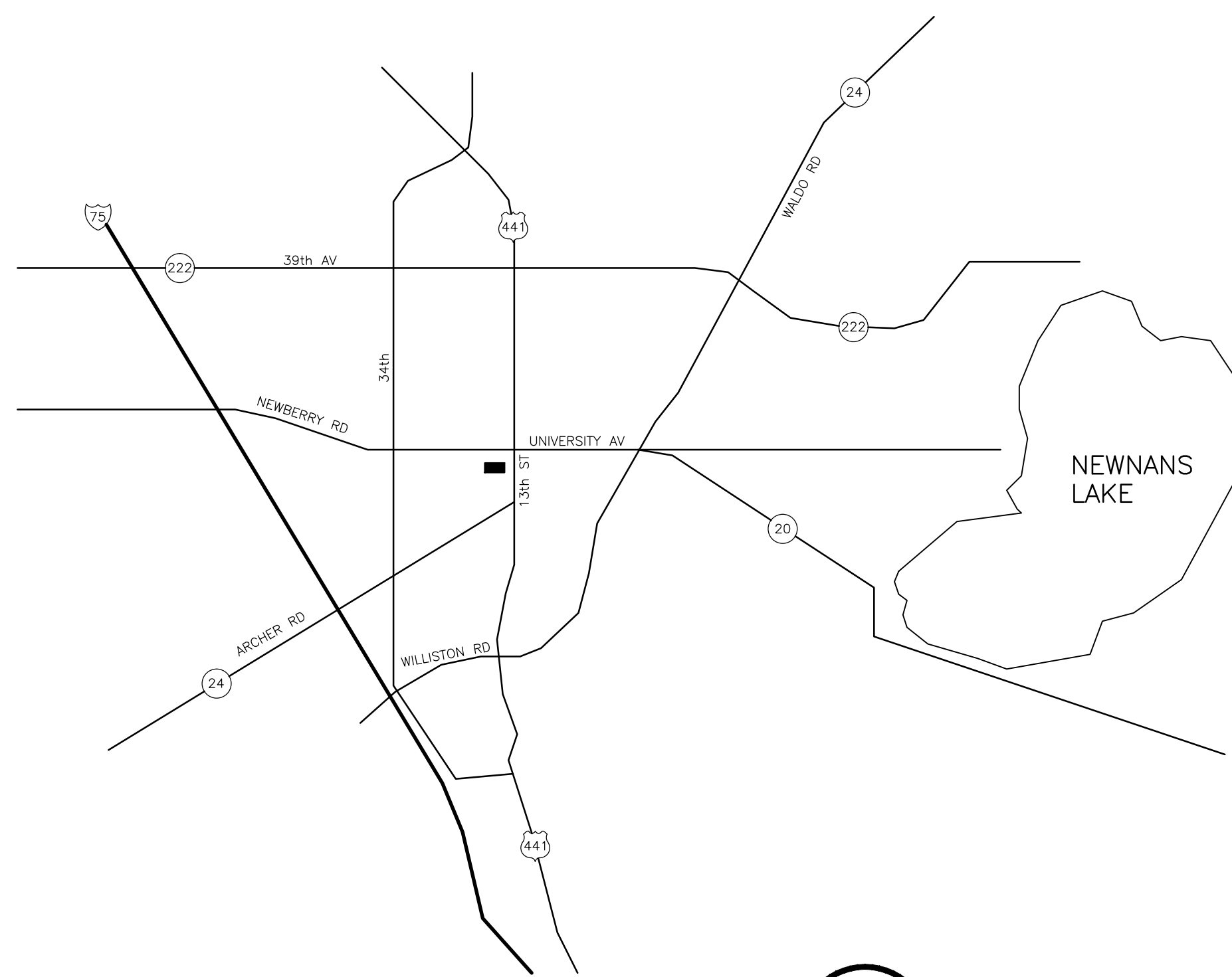

VICINITY MAP

NOT TO SCALE

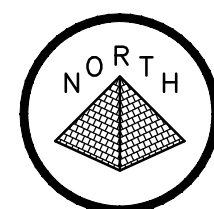

BIDDING DOCUMENTS

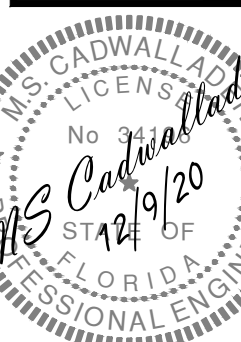

DATE: 12/9/20
 DRAWN: JRW
 APPROVED: MSC

1823

CS

OF 1 SHEETS

| AIR HANDLING UNIT SCHEDULE | | |
|--------------------------------------|----------------------|------------|
| UNIT DATA | UNITS | AHU-1 |
| PRODUCER AND MODEL No. | TEMTROL | ITF |
| UNIT TYPE | | HORIZONTAL |
| MINIMUM MOTOR H.P. | HP | 6-5HP |
| ELECTRICAL CHARACTERISTICS | V-Ø-Hz | 480-3-60 |
| FAN | CFM | 18,220 |
| OUTSIDE AIR | CFM | 9,000 |
| TOTAL STATIC PRESSURE | In. H ₂ O | 4.9 |
| EXTERNAL STATIC PRESSURE | In. H ₂ O | 1.6 |
| FAN | RPM | 2,747 |
| DESIGN TEMPERATURES | | |
| WINTER-OUTDOOR AND INDOOR | *F | 31-70 |
| SUMMER-OUTDOOR | *Fdb/Fwb | 96-80dp |
| SUMMER-INDOOR | *Fdb/Fwb | 75-60% |
| COOLING COIL DATA | | |
| SENSIBLE CAPACITY | BTU/Hr. | 527,900 |
| TOTAL CAPACITY | BTU/Hr. | 1,154,900 |
| MINIMUM FACE AREA | Sq.Ft. | 40.83 |
| ENTERING AIR TEMPERATURE | *Fdb/Fwb | 80-73 |
| LEAVING AIR TEMPERATURE | *Fdb/Fwb | 53.9-53.8 |
| ENTERING & LEAVING WATER TEMPERATURE | *F | 45-60 |
| WATER FLOW | GPM | 15.3 |
| PRESSURE DROP | Ft. H ₂ O | 9.03 |
| PIPE RUNOUT SIZE | In. | 3 |
| AIR PRESSURE DROP | In. H ₂ O | 0.77 |
| MINIMUM ROWS AND MAXIMUM FINS | In. | 8-8 |
| CONTROL VALVE TYPE | In. | 2-WAY 3" |

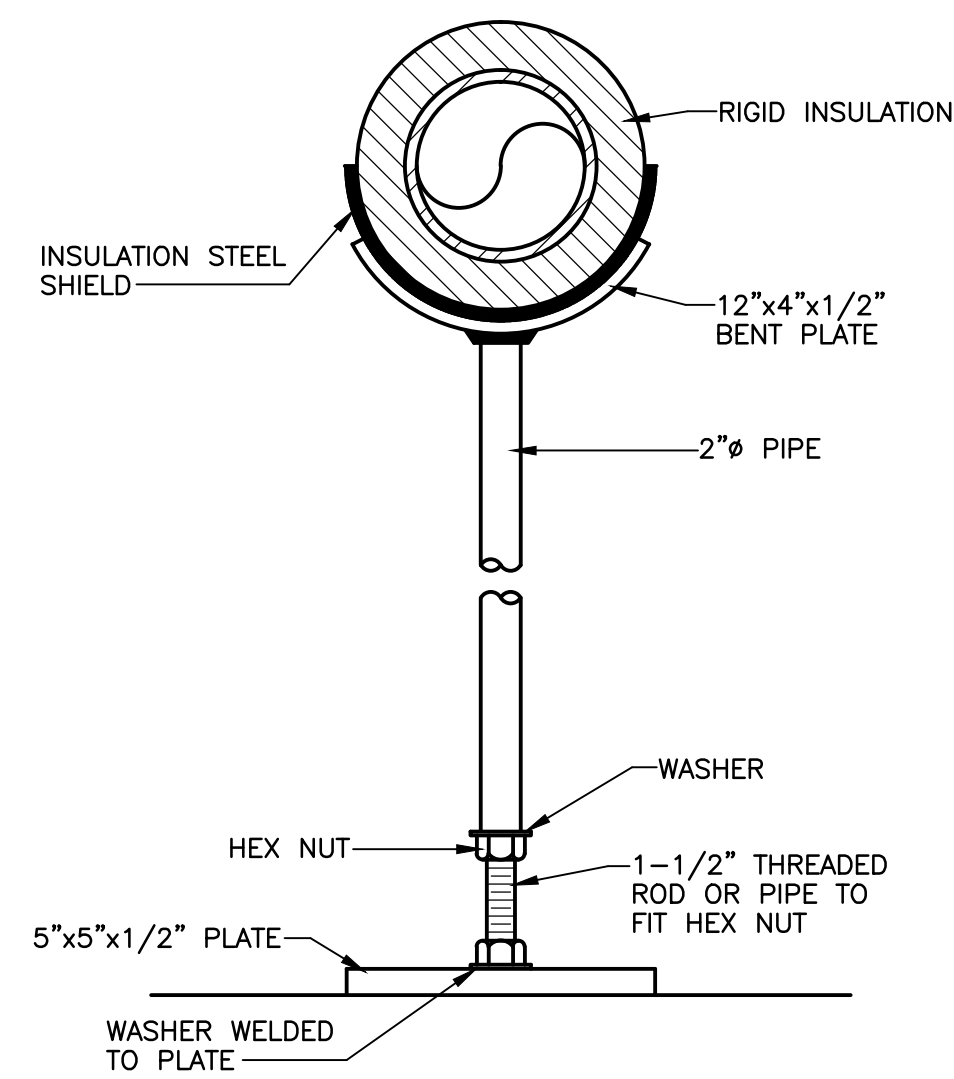

FLOOR PIPE SUPPORT
NO SCALE

| LEGEND | |
|---------|---|
| —CHWS— | CHILLED WATER SUPPLY |
| —CHWR— | CHILLED WATER RETURN |
| —C— | CONDENSATE |
| FD | FLOOR DRAIN |
| TCP | TEMPERATURE CONTROL PANEL |
| BAS | BUILDING AUTOMATION SYSTEM |
| SOV | SHUT-OFF BALL VALVE, BRONZE, TWO PIECE BODY, FULL PORT NIBCO T-585-70 2" AND SMALLER, IRON BODY RISING STEM 2 1/2" AND ABOVE. |
| — — | PIPE UNION |
| □ | BALANCING VALVE WITH PORTS |
| □ | PRESSURE GAUGE |
| ⊙ | DIAL THERMOMETER WITH 1/2" WELL |
| ⊙ | TEMPERATURE SENSOR |
| ⊙ | DENOTES CONNECT TO EXISTING |
| A | AUTOMATIC CONTROL DAMPER |
| — — | AIR VOLUME DAMPER |
| — — | DUCT MOUNTED SMOKE DETECTOR |
| VSD | VARIABLE SPEED FAN DRIVE |
| 100CFM | EXISTING RETURN AIR DEVICE WITH AIR QUANTITY |
| 100CFM | EXISTING SUPPLY AIR DEVICE WITH AIR QUANTITY |
| --- | DASHED DENOTES EXISTING EQUIPMENT AND DUCTWORK |
| ---E--- | EXISTING EXHAUST DUCTWORK |
| — — DG | EXISTING DOOR GRILLE |

GENERAL NOTES AND SPECIFICATIONS

- MECHANICAL AND PLUMBING WORK SHALL COMPLY WITH ALL APPLICABLE CODES AS ENFORCED BY THE AUTHORITIES HAVING JURISDICTION, INCLUDING (BUT NOT LIMITED TO):
2017 FLORIDA BUILDING CODE, SIXTH EDITION.
2017 FLORIDA BUILDING CODE - MECHANICAL.
2017 FLORIDA BUILDING CODE - PLUMBING.
2014 NATIONAL ELECTRICAL CODE.
2020 UF DESIGN AND CONSTRUCTION STANDARDS.
ASHRAE
- PROVIDE ALL MATERIALS AND EQUIPMENT AND PERFORM ALL LABOR REQUIRED TO INSTALL COMPLETE AND OPERABLE MECHANICAL SYSTEMS AS INDICATED ON THE DRAWINGS, AS SPECIFIED AND AS REQUIRED BY CODE.
- CONTRACT DOCUMENT DRAWINGS FOR MECHANICAL WORK ARE DIAGRAMMATIC AND ARE INTENDED TO CONVEY SCOPE AND GENERAL ARRANGEMENT ONLY.
- INSTALL ALL MECHANICAL EQUIPMENT AND APPURTENANCES IN ACCORDANCE WITH MANUFACTURERS' RECOMMENDATIONS, CONTRACT DOCUMENTS, AND APPLICABLE CODES AND REGULATIONS.
- USE FIRE-RATED PIPING SLEEVES FOR PIPING PENETRATIONS WITH FIRE RATED SEALANT AT FIRE-RATED WALLS. PROVIDE ESCUTCHEONS AT EXPOSED PIPING PENETRATIONS.
- LOCATE FLOW MEASURING DEVICES IN ACCESSIBLE LOCATIONS WITH STRAIGHT SECTION OF PIPE AS RECOMMENDED BY THE MANUFACTURER FOR GOOD ACCURACY.
- TESTING, ADJUSTING, AND BALANCING AGENCY SHALL BE A MEMBER OF THE ASSOCIATED AIR BALANCE COUNCIL (AABC) OR THE NATIONAL ENVIRONMENTAL BALANCING BUREAU (NEBB). TESTING, ADJUSTING, AND BALANCING SHALL BE PERFORMED IN ACCORDANCE WITH THE AABC STANDARDS. SUBMIT FOUR (4) COPIES. PERFORM PRE-TESTING OF AHU-1,4,&5 AND EF-12,16,17,18,19,20&21 AND ALL BUILDING AIR DEVICES PRIOR TO DEMOLITION. SUBMIT REPORT TO ENGINEER.
- THE LOCATIONS OF ALL ITEMS SHOWN ON THE DRAWINGS THAT ARE NOT DEFINITELY FIXED BY DIMENSIONS ARE APPROXIMATE ONLY. THE EXACT LOCATIONS NECESSARY TO SECURE THE BEST CONDITIONS AND RESULTS MUST BE DETERMINED BY THE PROJECT SITE CONDITIONS AND SHALL HAVE THE APPROVAL OF THE ENGINEER BEFORE BEING INSTALLED.
- ALL MISCELLANEOUS STEEL REQUIRED TO ENSURE PROPER INSTALLATION AND AS SHOWN IN DETAILS FOR PIPING, AND EQUIPMENT (UNLESS OTHERWISE NOTED) SHALL BE FURNISHED AND INSTALLED BY THE MECHANICAL CONTRACTOR.
- INSTALL PIPING SO THAT ALL VALVES, FLANGES, AND OTHER APPURTENANCES REQUIRING ACCESS ARE ACCESSIBLE.
- ALL VALVES (EXCEPT CONTROL VALVES) AND STRAINERS SHALL BE FULL SIZE OF PIPE BEFORE REDUCING SIZE TO MAKE CONNECTIONS TO EQUIPMENT AND CONTROLS.
- PERMIT AND INSPECTIONS BY UF EH&S ARE REQUIRED. INSPECTIONS BY FACILITIES SERVICES: CONTACT DAVID LOPEZ (352-294-0672)
- ALL PIPING WORK SHALL BE COORDINATED WITH EXISTING CONDITIONS AT THE SITE. OFFSET PIPING AROUND OBSTRUCTIONS.
- SCHEDULE ALL WORK AND UTILITY INTERRUPTIONS TWO WEEKS IN ADVANCE WITH GREG ROBERTS (352-294-3574).
- ALL PIPING SYSTEMS MUST BE CLEANED, CHEMICALLY TREATED, TESTED AND ACCEPTED BY HSC PHYSICAL PLANT DIVISION OPERATIONS ENGINEERING PRIOR TO BEING PLACED INTO SERVICE. CONTACT DAVID LOPEZ (352-294-0672) FOR INSPECTIONS.
- COMPLY WITH UF EH&S HOT WORK SAFETY POLICY: SEE <http://www.ehs.ufl.edu/programs/os/hotwork/>
UF HOT WORK PERMIT FORM: SEE http://www.ehs.ufl.edu/hotwork_permit.pdf
- PROVIDE PRODUCT SUBMITTALS FOR ALL EQUIPMENT, MATERIALS AND MECHANICAL CONTROLS TO ARCHITECT/ENGINEER FOR REVIEW.
- PROVIDE OPERATION AND MAINTENANCE MANUALS AT PROJECT CLOSE OUT PRIOR TO FINAL INSPECTION. INCLUDE WIRING DIAGRAMS, CONTROL DIAGRAMS, WARRANTIES, TEST AND BALANCE REPORT (4 COPIES). PROVIDE ONE PAPER COPY O&M'S AND ELECTRONIC MEDIA.
- MAINTAIN AND SUBMIT RECORD DRAWINGS OF AS-BUILT CONDITIONS.
- PROVIDE MOUNTED IDENTIFICATION TAGS FOR INSTALLED EQUIPMENT. IDENTIFY PIPING.
- THERMOMETERS: 2 1/2" DIAMETER DIAL THERMOMETERS (0-100°F) WITH ALUMINUM CASE, GLASS WINDOW AND COPPER STEM EQUAL TO WEISS.
- PRESSURE GAUGES: 4 1/2" DIAMETER, BRASS CASE WITH GLASS LENS (0-100psig)
- PROVIDE AUTOMATIC AIR VENTS AT HIGH POINTS AND DRAIN VALVES AT LOW POINTS.

- NOTES:**
- PROVIDE 4-INCH MERV. 13 FILTERS WITH PREFILTERS. DOUBLE WALL CONSTRUCTION.
 - PROVIDE STAINLESS STEEL CONDENSATE DRAIN PAN AND 16 GAUGE 304 STAINLESS STEEL COIL CASING.
 - UV LIGHT: EVERGREEN UV AR95-HL-2x2-75 RACK, 2.1 AMPS AT 120 VOLTS WITH URV-11 LAMP, JUNCTION BOX AND SWITCH.
 - PENTACUBE FANWALL. 5HP MAXIMUM SINGLE MOTOR SIZE.
 - PREMIUM EFFICIENCY INVERTER DUTY MOTOR WITH SHAFT GROUNDING.
 - PROVIDE FILTER PRESSURE ΔP GAUGE.
 - PROVIDE VARIABLE SPEED DRIVE FOR AIR HANDLING UNIT: MOTOR CONTROL, VARIABLE SPEED DRIVE. INCLUDE SHAFT GROUNDING. YASKAWA Z1000 SERIES VARIABLE SPEED DRIVE WITH BYPASS, LCD KEYPAD, HAND-OFF-AUTO, HARMONIC MITIGATION, NOISE FILTER, SERIAL COMMUNICATIONS WITH EMBEDDED BACNET (METASYS, MODBUS, APOGEE), UL LISTED, INTERNAL REAL-TIME CLOCK, PI FEATURE SET-UP MACROS AND ETHERNET IP. 30HP, 480V-3Ø-60HZ. DANFOSS AND EATON PRODUCTS ACCEPTABLE.
 - HORIZONTAL DRAW THRU WITH MULTIZONE DAMPER WITH NO BYPASS DECK.
 - PROVIDE ELECTRIC PREHEAT COIL: 40KW, 460V-3Ø-60HZ, WITH SCR CONTROLLER, 49F ENT, 56F LVG.
 - PROVIDE 8-15W LED LIGHTS INSIDE AHU WITH EXTERIOR SWITCH.
 - PROVIDE STAINLESS STEEL SECONDARY DRAIN PAN WITH FLOAT SWITCH ALARM IN PAN. PROVIDE 1" ISO MODE PADS BETWEEN AHU/SECONDARY PAN AND DRAIN PAN/FLOOR.

| PUMP SCHEDULE | | | | | | | | | |
|---------------|----------------------------|---------------|------------|-----------|--------|-----------------|-------|-------|-------------|
| UNIT NO. | MANUFACTURER AND MODEL NO. | SERVICE | EFFICIENCY | HEAD FEET | G.P.M. | ELECTRICAL DATA | | | REMARKS |
| | | | | | | HP | VOLT. | PHASE | |
| P-1 | AURORA 2 1/2x3x9 | CHILLED WATER | 74% | 60 | 290 | 7 1/2 | 460 | 60 | 1,2,3,4,5,6 |

- NOTES:**
- SINGLE STAGE END SUCTION SERIES 340.
 - MOTOR RPM 1750
 - PUMP TO REPLACE EXISTING 3HP PUMP.
 - PROVIDE PREMIUM EFFICIENCY INVERTER DUTY MOTOR WITH SHAFT GROUNDING.
 - REPLACE 3 HP VARIABLE SPEED DRIVE WITH (7 1/2 HP) MOTOR CONTROL, VARIABLE SPEED DRIVE. INCLUDE SHAFT GROUNDING, FULL BYPASS, LCD KEYPAD, HAND-OFF-AUTO, HARMONIC MITIGATION, NOISE FILTER, SERIAL COMMUNICATIONS WITH EMBEDDED BACNET (METASYS, MODBUS, APOGEE), UL LISTED, INTERNAL REAL-TIME CLOCK, PI FEATURE SET-UP MACROS AND ETHERNET IP. PROVIDE PRODUCTS BY YASKAWA, DANFOSS OR EATON.
 - MOUNT PUMP BASE WITH SPRING ISOLATORS. MODIFY EXISTING HOUSEKEEPING PAD FOR NEW PUMP DIMENSIONS.

| ELECTRIC RESISTANCE DUCTWORK MOUNTED HEATER SCHEDULE | | | | | | | | |
|--|--------|------|------|------------|----------------------|----------|-------|-----------|
| ZONE | SYMBOL | CFM | KW | EAT/LAT °F | ΔP "H ₂ O | V-Ø-HZ | STEPS | DUCT SIZE |
| AHU1-1 | ① | 1055 | 5.0 | 56/71 | 0.05 | 480-3-60 | 1 | 12"x14" |
| AHU1-2 | ② | 980 | 5.0 | 56/71 | 0.05 | 480-3-60 | 1 | 12"x14" |
| AHU1-3 | ③ | 740 | 4.0 | 56/76 | 0.05 | 480-3-60 | 2 | 8"x14" |
| AHU1-4 | ④ | 1225 | 6.0 | 56/72 | 0.05 | 480-3-60 | 2 | 12"x16" |
| AHU1-5 | ⑤ | 0 | --- | --- | --- | --- | --- | --- |
| AHU1-6 | ⑥ | 1480 | 8.0 | 56/75 | 0.05 | 480-3-60 | 2 | 15"x14" |
| AHU1-7 | ⑦ | 1395 | 8.0 | 56/74 | 0.05 | 480-3-60 | 2 | 15"x14" |
| AHU1-8 | ⑧ | 1770 | 12.0 | 56/78 | 0.05 | 480-3-60 | 2 | 19"x14" |
| AHU1-9 | ⑨ | 1450 | 8.0 | 56/73 | 0.05 | 480-3-60 | 2 | 28"x8" |
| AHU1-10 | ⑩ | 1390 | 8.0 | 56/74 | 0.05 | 480-3-60 | 2 | 28"x8" |
| AHU1-11 | ⑪ | 3200 | 15.0 | 56/72 | 0.05 | 480-3-60 | 3 | 30"x12" |
| AHU1-12 | ⑫ | 2175 | 11.0 | 56/73 | 0.05 | 480-3-60 | 2 | 17"x14" |
| AHU1-13 | ⑬ | 1330 | 6.0 | 56/73 | 0.05 | 480-3-60 | 2 | 18"x10" |

- NOTES:**
- PROVIDE DISCONNECT SWITCHES INTERLOCKED WITH CONTROL TERMINAL BOX.
 - PROVIDE P.E. SWITCH FOR EACH STEP IN CONTROL CABINET.
 - PROVIDE AIR FLOW SWITCH.
 - PROVIDE AUTOMATIC RESET THERMAL SAFETY CONTROL AND SECONDARY OVER-TEMPERATURE CONTROL.
 - MARKEL OPEN COIL INCERT ELECTRIC RESISTANCE HEATER BASIS OF DESIGN.
 - EXISTING HVAC CONTROLS ARE JOHNSON.
 - ZONE 1-5 IS CAPPED.
 - COORDINATE DUCT HEATER DIMENSIONS WITH FIELD MEASURED DUCTWORK SIZES.

| EXISTING EXHAUST FAN SCHEDULE | | | | | | | | | | | | |
|-------------------------------|-------|--------|------------------|-------------------------------------|-----------|-------------|-------------------|--------|--------------|-------|---------|--|
| AREA SERVED | MARK | TYPE | AIR QUANTITY CFM | STATIC PRESSURE IN H ₂ O | SPEED RPM | MOTOR POWER | ELEC. CHAR. (V-Ø) | MANUF. | MODEL NUMBER | SONES | REMARKS | |
| TOILET ROOMS | EF-12 | ROOF | 1000 | 0.25 | 840 | 0.091 HP | 120-1 | COOK | 135 ACEB | 4.7 | ② | |
| 316 | EF-16 | ROOF | 360 | 0.125 | 961 | 0.044 HP | 120-1 | COOK | 80 ACEB | 3.5 | ① | |
| 201/205 | EF-17 | ROOF | 2622 | 0.375 | 1129 | 0.553 HP | 480-3 | COOK | 165 ACRUB | 16.1 | ② | |
| PHOTOGRAPHY | EF-18 | ROOF | 2710 | 0.5 | 1153 | 0.596 HP | 480-3 | COOK | 165 ACRUB | 16.5 | ② | |
| 101, 105, 107 | EF-19 | INLINE | 3560 | 0.25 | 364 | 0.654 HP | 480-3 | COOK | DB-18 | 11.8 | ② | |
| 115 & 117 | EF-20 | INLINE | 2800 | 0.25 | 331 | 0.422 HP | 480-3 | COOK | DB-18 | 9.7 | ② | |
| 215 | EF-21 | INLINE | 1090 | 0.25 | 509 | 0.134 HP | 277-1 | COOK | DB-10 | 5.6 | ② | |

- ① PROVIDE NEW DIGITAL WALL THERMOSTAT FOR CONTROL OF FAN.
② FAN TO RUN CONTINUOUSLY DURING OCCUPIED HOURS VIA AHU INTERLOCK.

| DESIGN CRITERIA |
|---|
| DESIGN TEMPERATURES: OUTSIDE WINTER 31°Fdb INSIDE WINTER 70°Fdb OUTSIDE SUMMER 96°Fdb-80°F DEW POINT INSIDE SUMMER 75°Fdb-MAX 60% RH |
| CONTROLS: 1. AUTOMATIC CONTROLS AND VSD. |

PIPE SCHEDULE

CHILLED WATER:
SCHEDULE 40 BLACK STEEL OR TYPE L COPPER WITH 1 1/2" CELLULAR GLASS INSULATION WITH VAPOR BARRIER SEALANT AND ALUMINUM JACKET.

CONDENSATE PIPING:
TYPE L COPPER WITH ARMA FLEX INSULATION.

DUCTWORK SCHEDULE

GALVANIZED STEEL CONSTRUCTED IN ACCORDANCE WITH SMACNA AND ASHRAE STANDARDS. INSULATE SUPPLY AND RETURN AIR DUCTWORK WITH 1 1/2-INCH (R=4.2) FIBERGLASS WITH VAPOR BARRIER. EXPOSED DUCTWORK SHALL BE INSULATED WITH RIGID DUCT BOARD. DUCTWORK SIZES ON DRAWINGS ARE SHEETMETAL SIZES.

Cadwallader & Associates, Inc.
CONSULTING ENGINEERS
EB 1872
4000 SW 35TH TERRACE, GAINESVILLE, FLORIDA, 32608
E-MAIL: cadwallader@bellsouth.net
TEL. NO. 352-376-0520

UF FINE ARTS "D" - BUILDING NO. 0269
REPLACE AIR HANDLING UNIT AHU-1
UNIVERSITY OF FLORIDA
MINOR PROJECT NO. MP04468
GAINESVILLE, FLORIDA



DATE: 12/9/20
DRAWN: JRW
APPROVED: MSC

1823

M-1

OF SHEETS 6

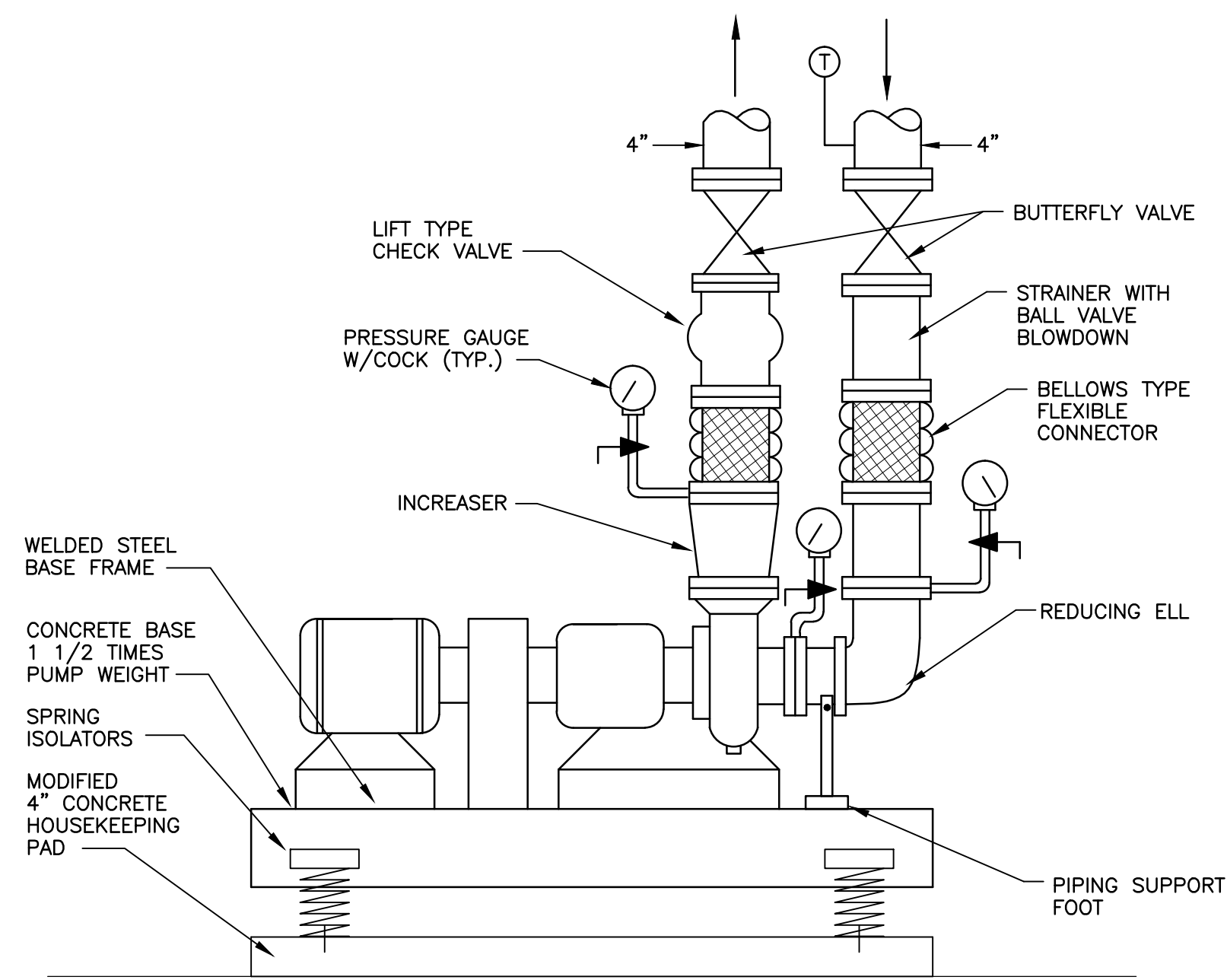

END SUCTION PUMP DETAIL
NO SCALE

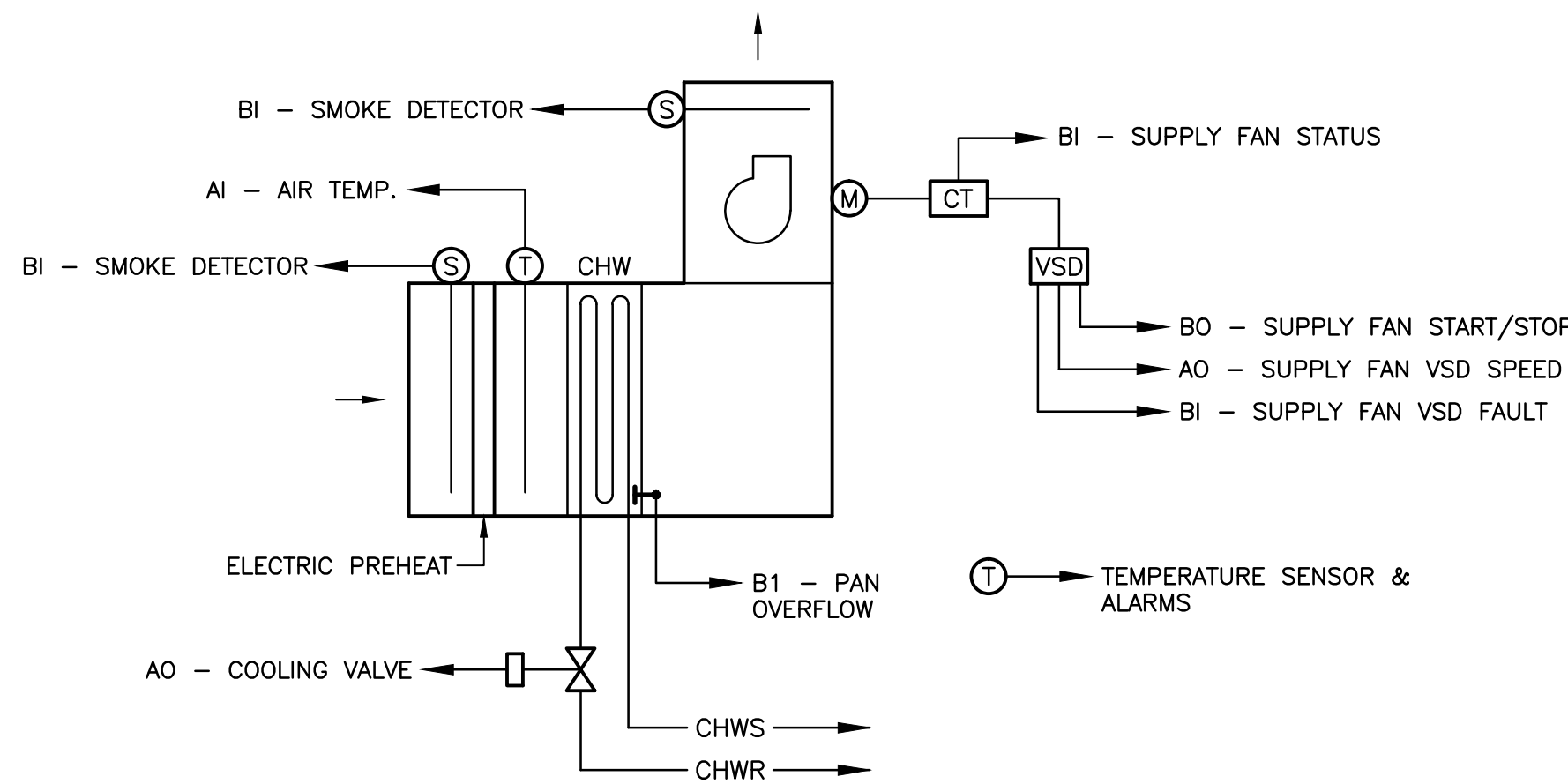

AHU CONTROL DIAGRAM
NO SCALE

| | HVAC CONTROL POINT SCHEDULE | | | | SYSTEM FEATURES |
|--------------------------------------|-----------------------------|--------|--------|--------|-----------------|
| | ANALOG | BINARY | BINARY | ANALOG | |
| CHW FLOW (GPM) | | | | | |
| WATER TEMP SUPPLY AND RETURN | | | | | |
| RETURN AIR TEMP | | | | | |
| LEAVING AIR TEMP | | | | | |
| ZONE TEMPERATURE | | | | | |
| ELECTRIC PREHEAT | | | | | |
| OUTSIDE AIR TEMP | | | | | |
| MIXED AIR HUMIDITY | | | | | |
| STATUS | | | | | |
| FILTER DETECTORS | | | | | |
| DAMPERS POSITION (DA) | | | | | |
| DRAIN PAN OVER FLOW | | | | | |
| OFF - ON | | | | | |
| DA DAMPER | | | | | |
| ZONE HEATER LVG. TEMP. | | | | | |
| COOLING COIL LVG. TEMP. | | | | | |
| CHW VALVE POSITION | | | | | |
| VARIABLE FREQUENCY DRIVE CONTROL-AHU | | | | | |
| VARIABLE FREQUENCY DRIVE PUMP P-1 | | | | | |
| LVG. TEMPERATURE | | | | | |
| DRY LEAK | | | | | |
| LOSS OF OPERATION | | | | | |
| DRAIN PAN SAFETY OVERFLOW | | | | | |
| FREEZE STAT | | | | | |
| TIME SCHEDULE | | | | | |
| DUPLICATE | | | | | |
| CONTROL GRAPHICS | | | | | |
| INTERLOCK | | | | | |
| AHU-1 & 4 | | | | | |
| DUCT HEATERS | | | | | |
| EXHAUST FANS | | | | | |
| CHILLED PUMP | | | | | |

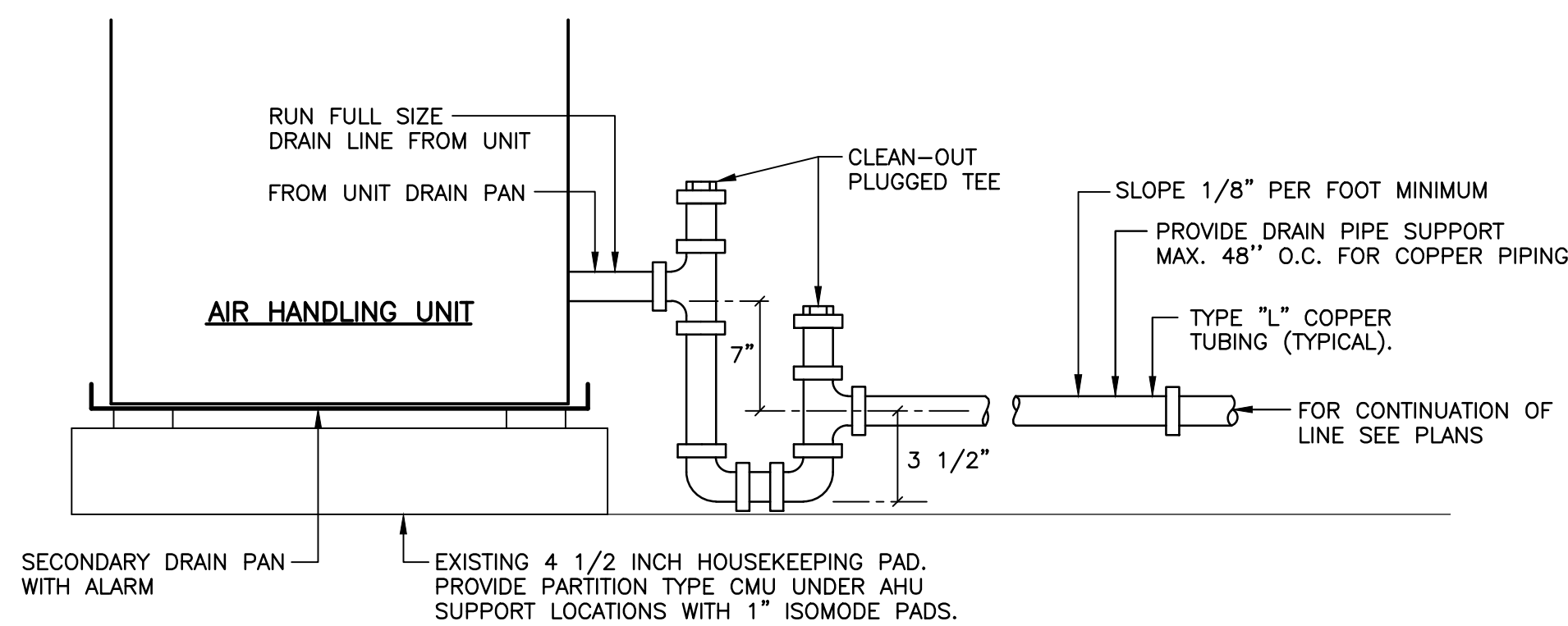

AIR HANDLING UNIT CONDENSATE DRAIN DETAIL
NO SCALE

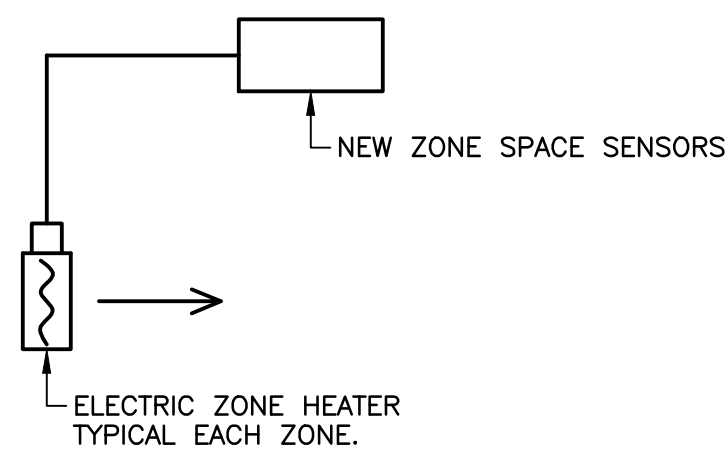

ZONE CONTROL: ROOM TEMPERATURE SENSOR WILL MODULATE ZONE ELECTRIC DUCT HEATER IN SEQUENCE TO MAINTAIN ADJUSTABLE ZONE TEMPERATURE SETPOINT.
NOTE: EXISTING CONTROLS ARE JOHNSON. CONTROLS TO CAMPUS N-2 AT FIRST FLOOR MECHANICAL EQUIPMENT ROOM.

ZONE ELECTRIC HEATER CONTROL DIAGRAM
NOT TO SCALE

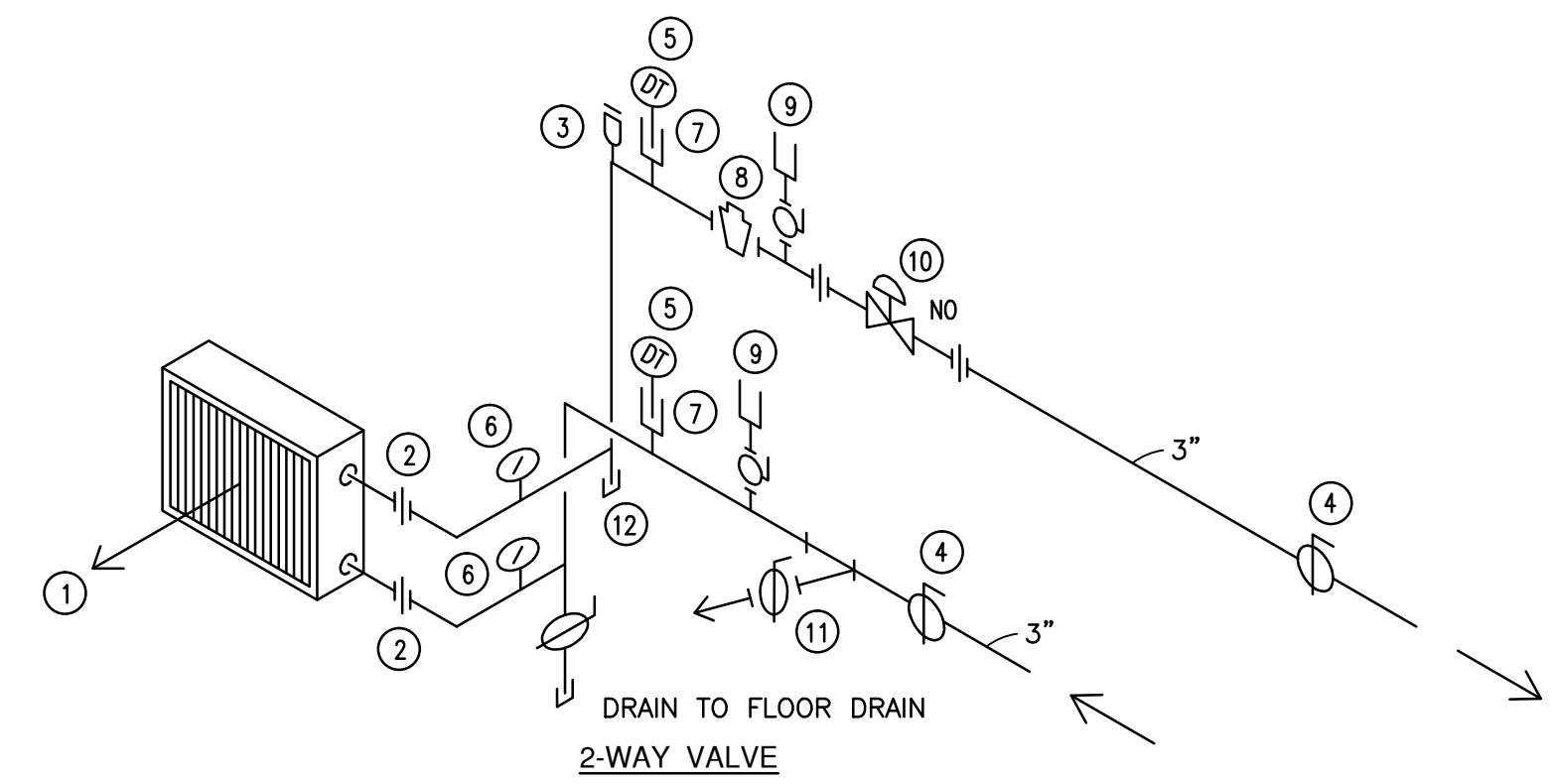

- ① AIR FLOW
- ② UNION - TYPICAL
- ③ AUTOMATIC AIR VENT AT PIPING HIGH POINT
- ④ EXISTING VALVE
- ⑤ DIAL THERMOMETER IN WELL
- ⑥ PRESSURE GAUGE
- ⑦ THERMOMETER WELL TYPICAL
- ⑧ CALIBRATED BALANCING COCK WITH TAPS
- ⑨ PRESSURE TAPS
- ⑩ 2-WAY CONTROL VALVE
- ⑪ FULL SIZE STRAINER WITH FLUSHING VALVE
- ⑫ DIRT LEG

AIR HANDLING UNIT PIPING DIAGRAM
NO SCALE

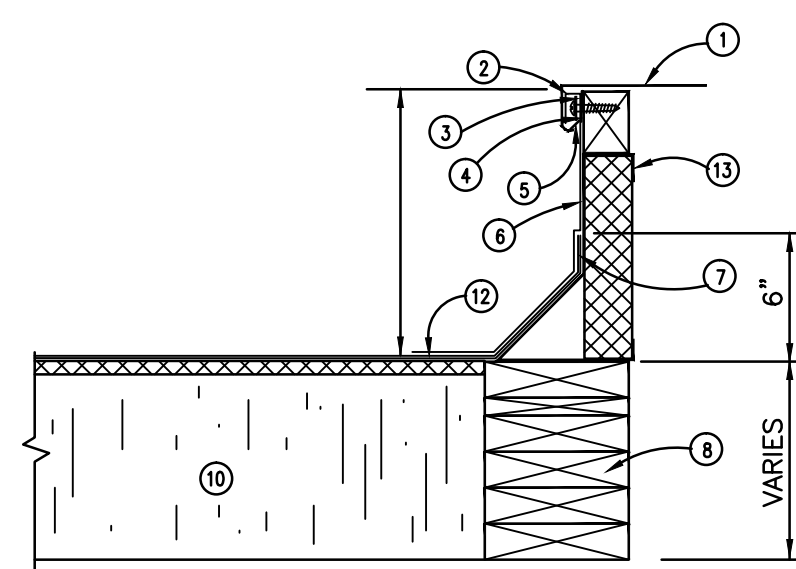

- ① OUTSIDE AIR INTAKE MOUNTING BASE
- ② EXTEND HYPLON FLASHING SHEET TO COVER TERMINATION BAR TO PREVENT GALVANIC ACTION.
- ③ 1/8"x1" S.S. TERMINATION BAR FASTENED @ 8" O.C.
- ④ 1" FLASHING TAPE ON EACH SIDE OF HYPLON FLASHING SHEET.
- ⑤ .050 ALUMINUM CLEAT
- ⑥ HYPLON FLASHING SHEET SET IN COLD ADHESIVE.
- ⑦ EXTEND BASE SHEET & ROOF MEMBRANE MIN. 6" ABOVE FINISHED DECK.
- ⑧ P.T. 6" WIDE NAILERS AS REQUIRED FOR THICKNESS OF INSULATION. SECURE TO DECK W/ PWDR. ACT. FASTENERS @ 24" O.C.
- ⑨ NOT USED
- ⑩ ROOF ASSEMBLY
- ⑪ NOT USED
- ⑫ ROOF MEMBRANE
- ⑬ PREFABRICATED ALUMINUM CURB

ROOF CURB ATTACHMENT DETAIL
NO SCALE

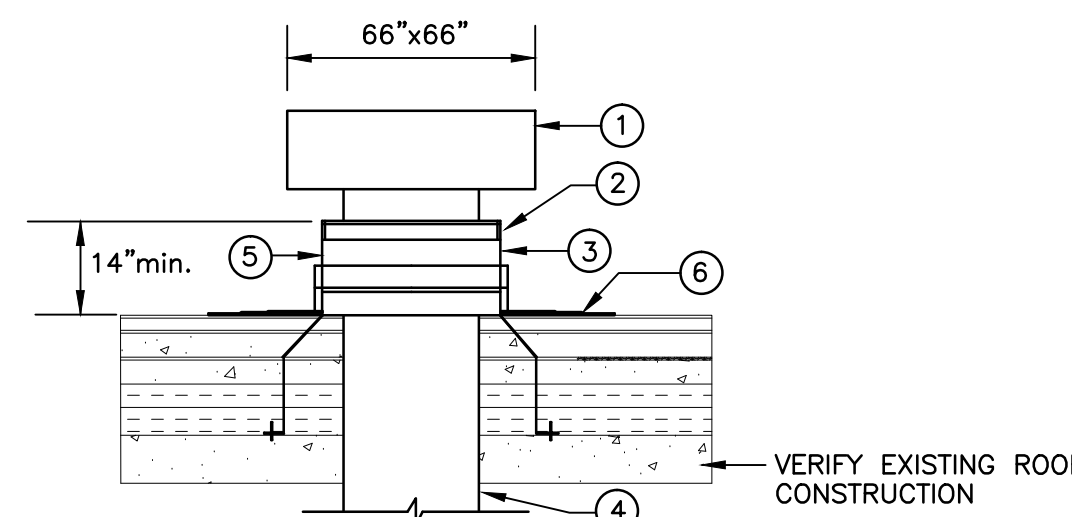

- ① NEW ROOF MOUNTED OUTSIDE AIR INTAKE
- ② SEE ROOF CURB ATTACHMENT DETAIL THIS SHEET
- ③ PROVIDE A NEW ROOF CURB WITH HURRICANE TIE DOWN TABS ANCHORED TO CURB IN FOUR PLACES. ATTACH WITH SCREW-TYPE REMOVABLE CLEVISES.
- ④ NEW 36"x36" OA DUCT
- ⑤ EXTEND OUTSIDE AIR DUCT TO TOP OF CURB CAP
- ⑥ ROOF FLASHING

ROOF MOUNTED OUTSIDE AIR INTAKE
NO SCALE

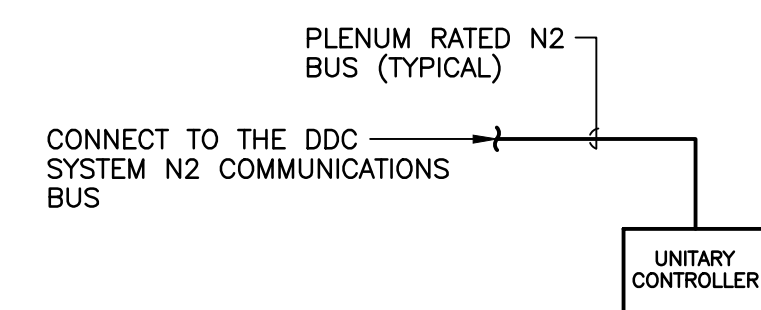

- NOTES:
- DIVISION 15 SHALL PROVIDE ALL CABLE AND CONDUIT FOR EMCS. ALL CABLE IN EQUIPMENT ROOM SHALL BE IN CONDUIT.
 - THE CONTROLS CONTRACTOR SHALL VERIFY DDC EQUIPMENT, AND THE APPLICATIONS FOR UTILIZATION, WITH UF FACILITIES SERVICES DEPARTMENT. THE NEW JOHNSON "METASYS" BASED SYSTEM SHALL INTERFACE WITH THE EXISTING JOHNSON CONTROL SYSTEMS.

EMCS CONTROL DIAGRAM
NO SCALE

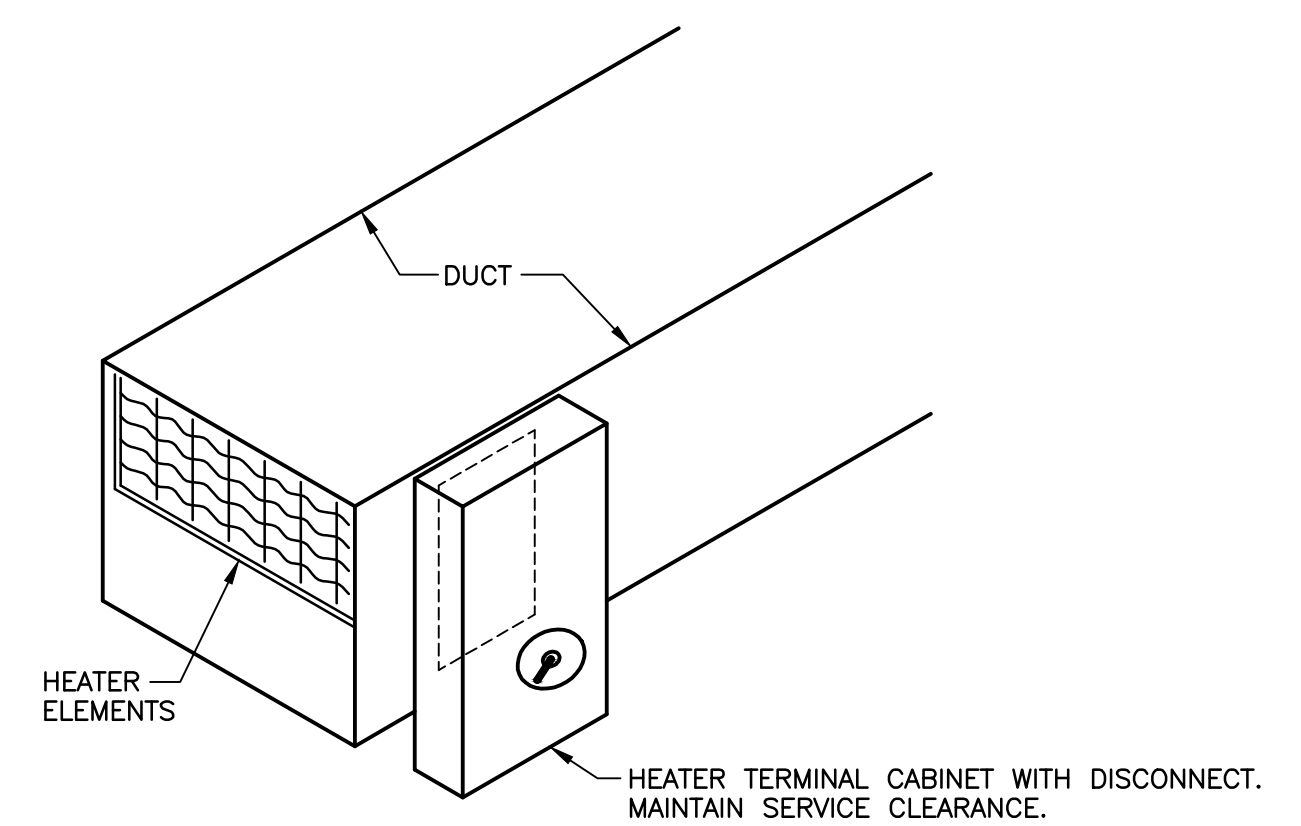

ELECTRIC DUCT MOUNTED HEATER DETAIL
NOT TO SCALE

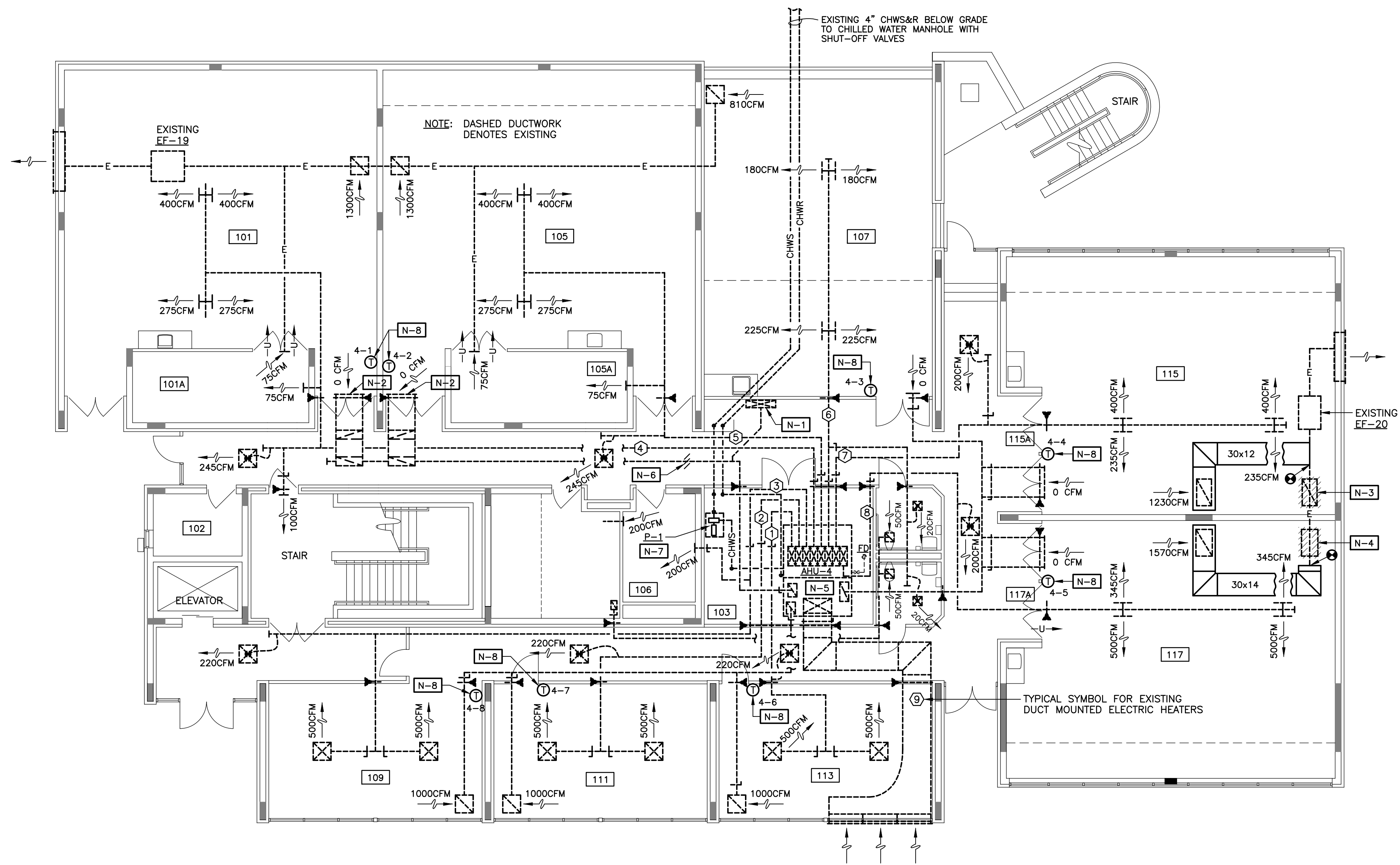

FIRST FLOOR HVAC PLAN

SCALE: 1/8" = 1'-0"

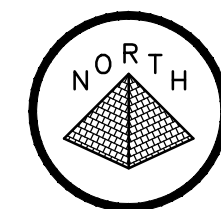

PLAN NOTES:

- N-1** 40"x10" SUPPLY DUCT FROM AHU-5 ON 2ND FLOOR CONNECTED TO 30"x10" RETURN AIR DUCT IN CORRIDOR.
- N-2** SET RETURN AIR FLOW WITH AHU-5 ENABLED.
- N-3** RELOCATE 36"x20" EXHAUST GRILL AS SHOWN. PATCH DUCT AT EXISTING EXHAUST DEVICE LOCATION.
- N-4** RELOCATE 36"x22" EXHAUST GRILL AS SHOWN. PATCH DUCT AT EXISTING EXHAUST DEVICE LOCATION.
- N-5** AHU-4 EXISTING MULTIZONE CHILLED WATER UNIT.
- N-6** EXISTING BACKDRAFT DAMPER SERVING 30"x10" RETURN AIR DUCT SERVING ROOMS 101 AND 105.
- N-7** REPLACE EXISTING CHILLED WATER PUMP P-1 WITH NEW CHILLED WATER PUMP P-1. RECONNECT TO EXISTING PIPING.
- N-8** REPLACE PNEUMATIC THERMOSTATS WITH DIGITAL ZONE SENSORS.

ROOM FLOOR AIR BALANCE:

| | | |
|--------------------------|---|------------|
| TOTAL SUPPLY AIR BALANCE | - | 11,470 CFM |
| OUTSIDE AIR AHU-4 | - | 5,200 CFM |
| OUTSIDE AIR AHU-5 | - | 3,100 CFM |
| TOTAL EXHAUST AIR | - | 6,430 CFM |
| POSITIVE | - | 1,870 CFM |



DATE: 12/9/20
DRAWN: JRW
APPROVED: MSC

1823

M-3

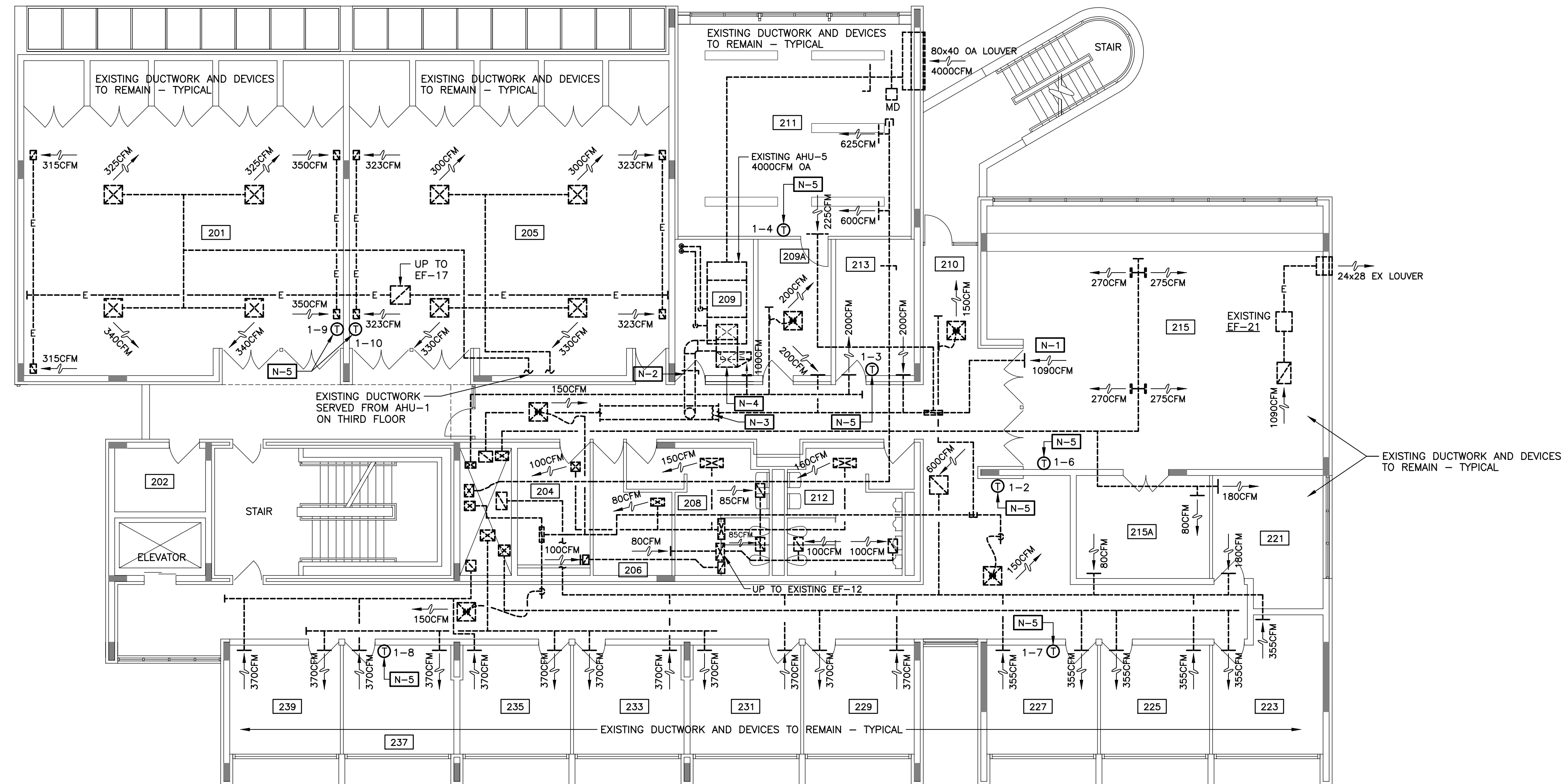

SECOND FLOOR HVAC PLAN

SCALE: 1/8" = 1'-0"

PLAN NOTES:

- N-1** SET RETURN DEVICE FOR 1090 CFM WITH AHU-5 DISABLED.
- N-2** SET AHU-5 9% SUPPLY AIR QUANTITY TO 900 CFM.
- N-3** EXISTING BACK DRAFT DAMPER.
- N-4** EXISTING 28"x20" TO 40"x12" SUPPLY AIR DUCT DOWN TO FIRST FLOOR. SET AIR QUANTITY TO 3,100 CFM.
- N-5** REPLACE PNEUMATIC THERMOSTATS WITH DIGITAL ZONE SENSORS.



ROOM FLOOR AIR BALANCE:

| | | |
|------------------------------|---|------------|
| TOTAL SUPPLY AIR | - | 10,040 CFM |
| OUTSIDE AIR 10,040 CFM x 53% | - | 5,321 CFM |
| EXHAUST AIR | - | 4,262 CFM |
| POSITIVE | - | 1,059 CFM |



DATE:
12/9/20
DRAWN:
JRW
APPROVED:
MSC

1823

M-4

OF
SHEETS 6

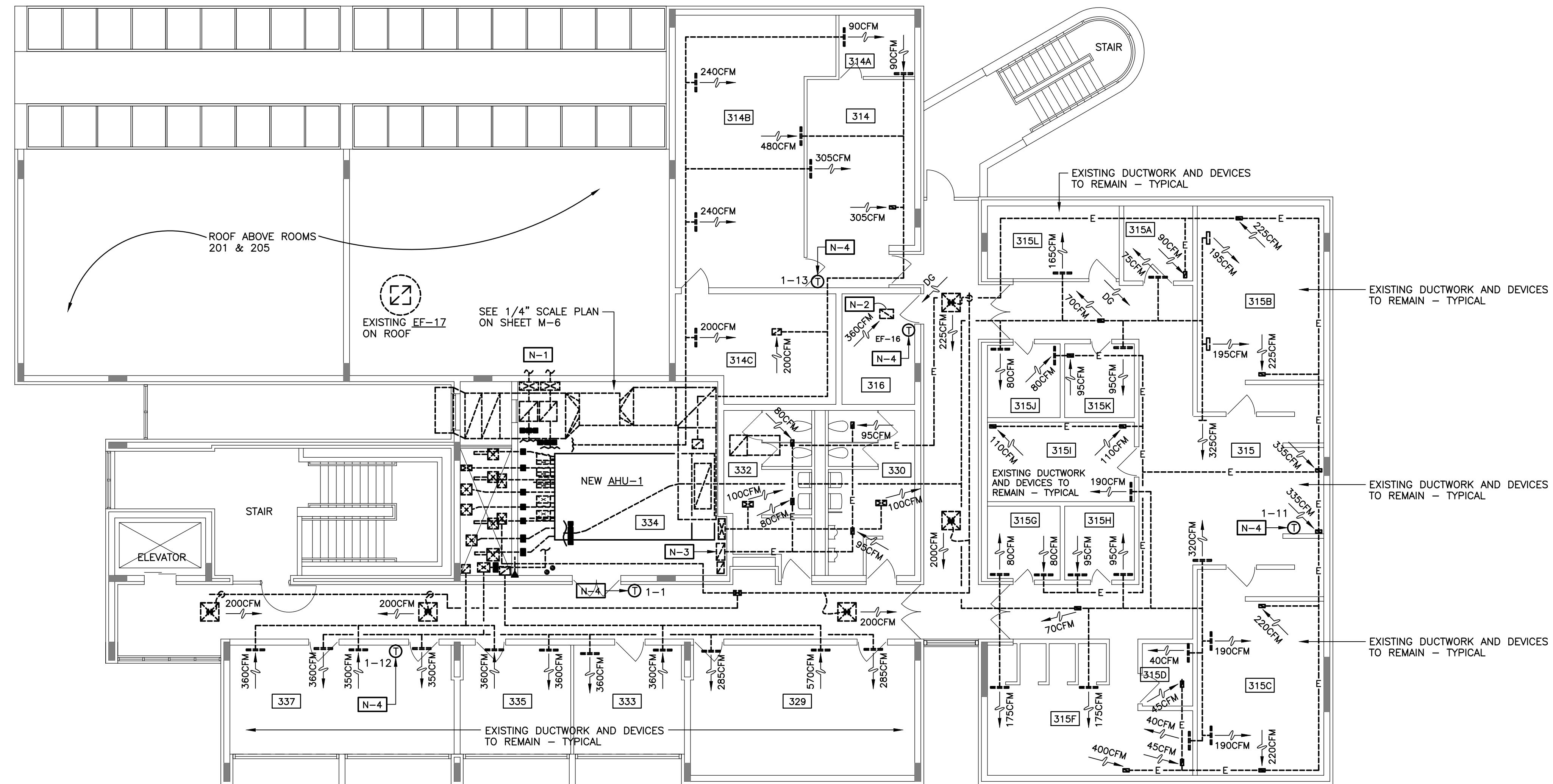

THIRD FLOOR HVAC PLAN

SCALE: 1/8" = 1'-0"

PLAN NOTES:

- N-1** SEE SHEET M-4 FOR CONTINUATION OF EXISTING SUPPLY AND EXHAUST DUCTWORK SERVING ROOMS 201 AND 205.
- N-2** EXISTING EXHAUST DUCTWORK TO EXISTING EF-16 ON ROOF ABOVE.
- N-3** EXISTING EXHAUST RISER UP TO EF-12 ON ROOF.
- N-4** REPLACE PNEUMATIC THERMOSTATS WITH DIGITAL ZONE SENSORS.

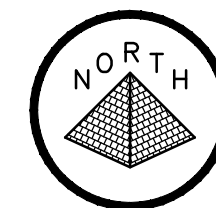

ROOM FLOOR AIR BALANCE:

| | | |
|-----------------------------|---|-----------|
| TOTAL SUPPLY AIR | - | 6,855 CFM |
| OUTSIDE AIR 6,855 CFM x 53% | - | 3,652 CFM |
| EXHAUST AIR | - | 3,420 CFM |
| POSITIVE | - | 232 CFM |



DATE: 12/9/20
 DRAWN: JRW
 APPROVED: MSC

1823

M-5

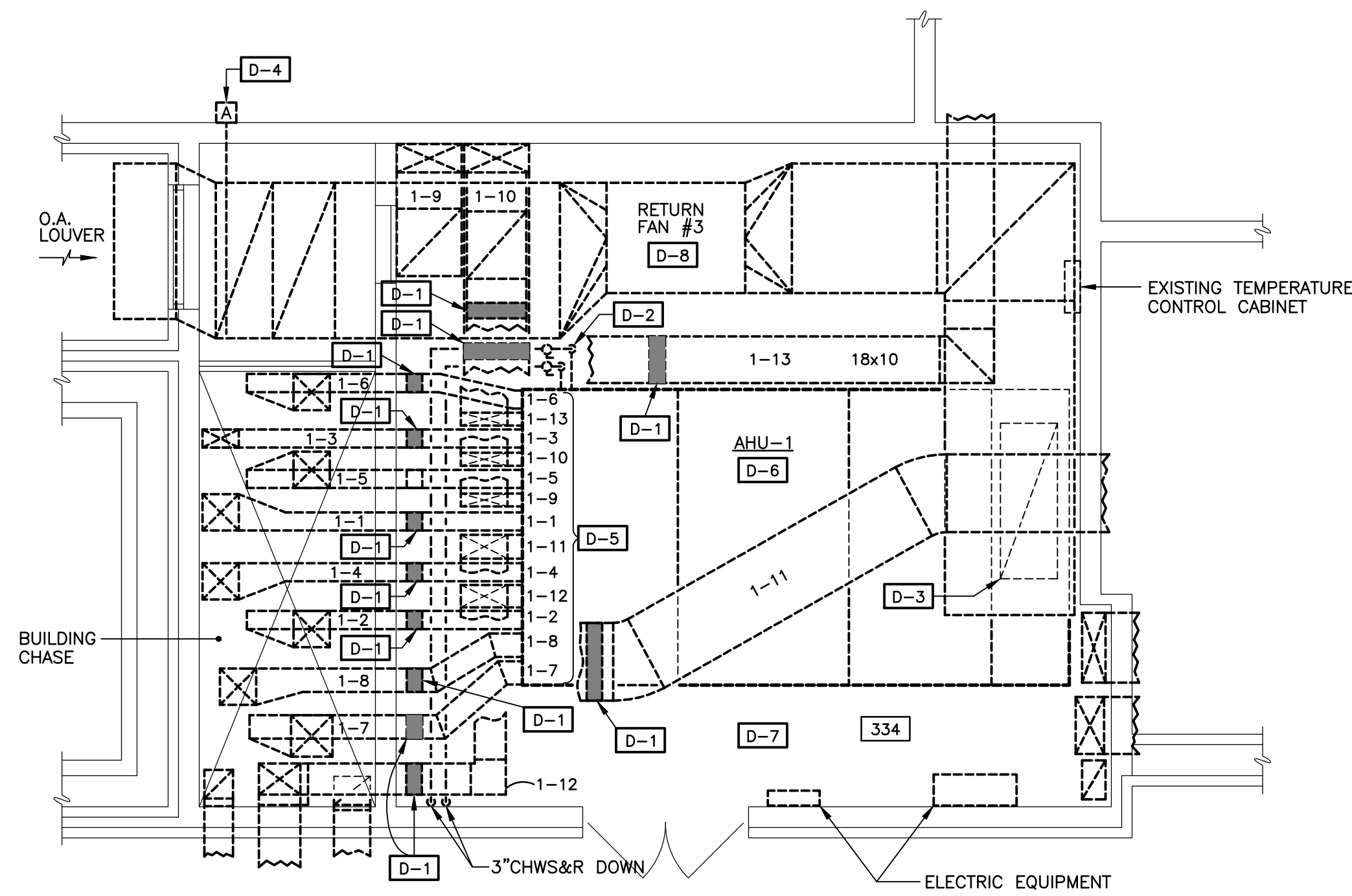

THIRD FLOOR MECHANICAL ROOM 334 HVAC DEMOLITION PLAN

SCALE: 1/4" = 1'-0"

DEMOLITION NOTES:

- D-1** REMOVE ZONE ELECTRIC RESISTANCE DUCT MOUNTED HEATER AND MECHANICAL CONTROLS.
- D-2** REMOVE 3" CHWS&R PIPING, INSULATION, PIPING DEVICES FROM SHUT-OFF VALVES TO AHU-1 CHILLED WATER COIL.
- D-3** REMOVE RETURN AIR DUCTWORK DROP TO AHU-1 MIXING BOX.
- D-4** REMOVE PNEUMATIC CONTROLLED AUTOMATIC OUTSIDE AIR DAMPER AND CONTROLS.
- D-5** REMOVE ZONE SUPPLY AIR DUCTWORK, INSULATION FROM ZONE AHU DAMPERS UP TO ELECTRIC DUCT HEATER LOCATION.
- D-6** DISASSEMBLE AHU-1 IN SECTIONS AND REMOVE FROM SITE.
- D-7** PERFORM PRE TEST AND BALANCE REPORT. SUBMIT TO ENGINEER PRIOR TO DEMOLITION.
- D-8** REMOVE RETURN FAN #3, DUCTWORK TRANSITIONS AND SUPPORTS.

EXISTING AHU-1 ZONE SCHEDULE

| ZONE # | EXISTING CFM | ROOM SERVED |
|--------|--------------|-------------|
| 1-1 | 1055 | 399 |
| 1-2 | 980 | 210 |
| 1-3 | 640 | 213 |
| 1-4 | 1225 | 211 |
| 1-5 | 0 | --- |
| 1-6 | 1360 | 215 |
| 1-7 | 1395 | 227 |
| 1-8 | 1770 | 237 |
| 1-9 | 1450 | 201 |
| 1-10 | 1390 | 205 |
| 1-11 | 3050 | 315 |
| 1-12 | 2025 | 337 |
| 1-13 | 1150 | 314 |
| TOTAL | 17,490 | --- |

1. TESTING UNIT PRIOR TO AHU REPLACEMENT IS PART OF SCOPE.
2. ZONE 5 IS CAPPED.

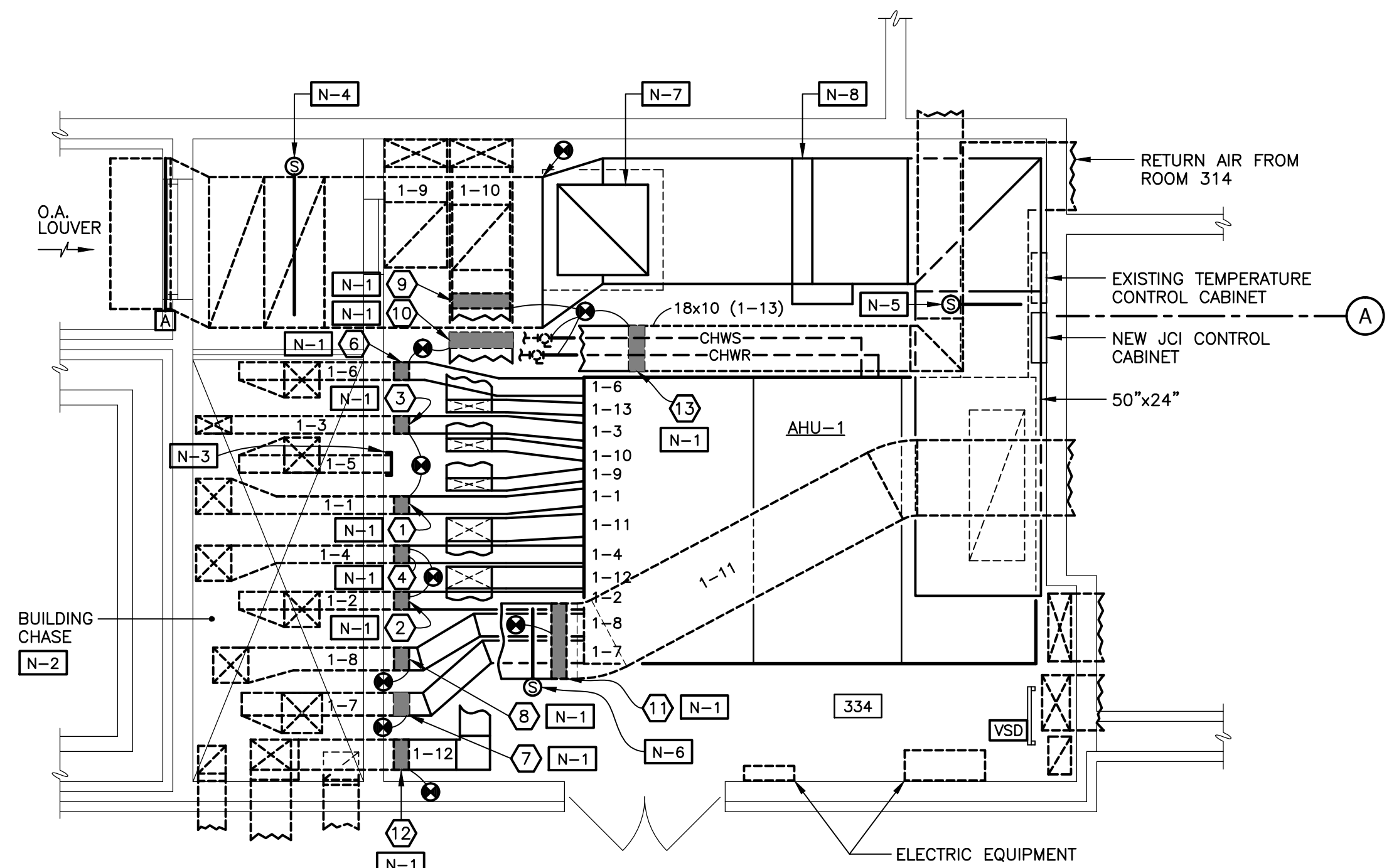

THIRD FLOOR MECHANICAL ROOM 334 HVAC PLAN

SCALE: 1/4" = 1'-0"

DRAWING NOTES:

- N-1** INSTALL NEW ZONE ELECTRIC HEATER IN ZONE DUCTWORK. PATCH DUCTWORK AND REINSULATE ZONE DUCTWORK AND ELECTRIC HEATER AS REQUIRED.
- N-2** DUCTWORK PENETRATIONS OF BUILDING CHASE ARE PROTECTED BY FIRE DAMPERS.
- N-3** CAP ZONE 1-5. REMOVE DUCTWORK TO AHU-1.
- N-4** INSTALL DUCT MOUNTED SMOKE DETECTOR IN RETURN AIR RISER IN DUCT CHASE PRIOR TO OUTDOOR AIR MIXING.
- N-5** INSTALL DUCT MOUNTED SMOKE DETECTOR IN RETURN AIR DUCT SERVING ROOM 314.
- N-6** INSTALL DUCT MOUNTED SMOKE DETECTOR IN SUPPLY AIR DUCT.
- N-7** 36"x36" OA DUCT DOWN FROM ROOF MOUNTED OA INTAKE.
- N-8** DUCT MOUNTED 40KW ELECTRIC REHEAT COIL.

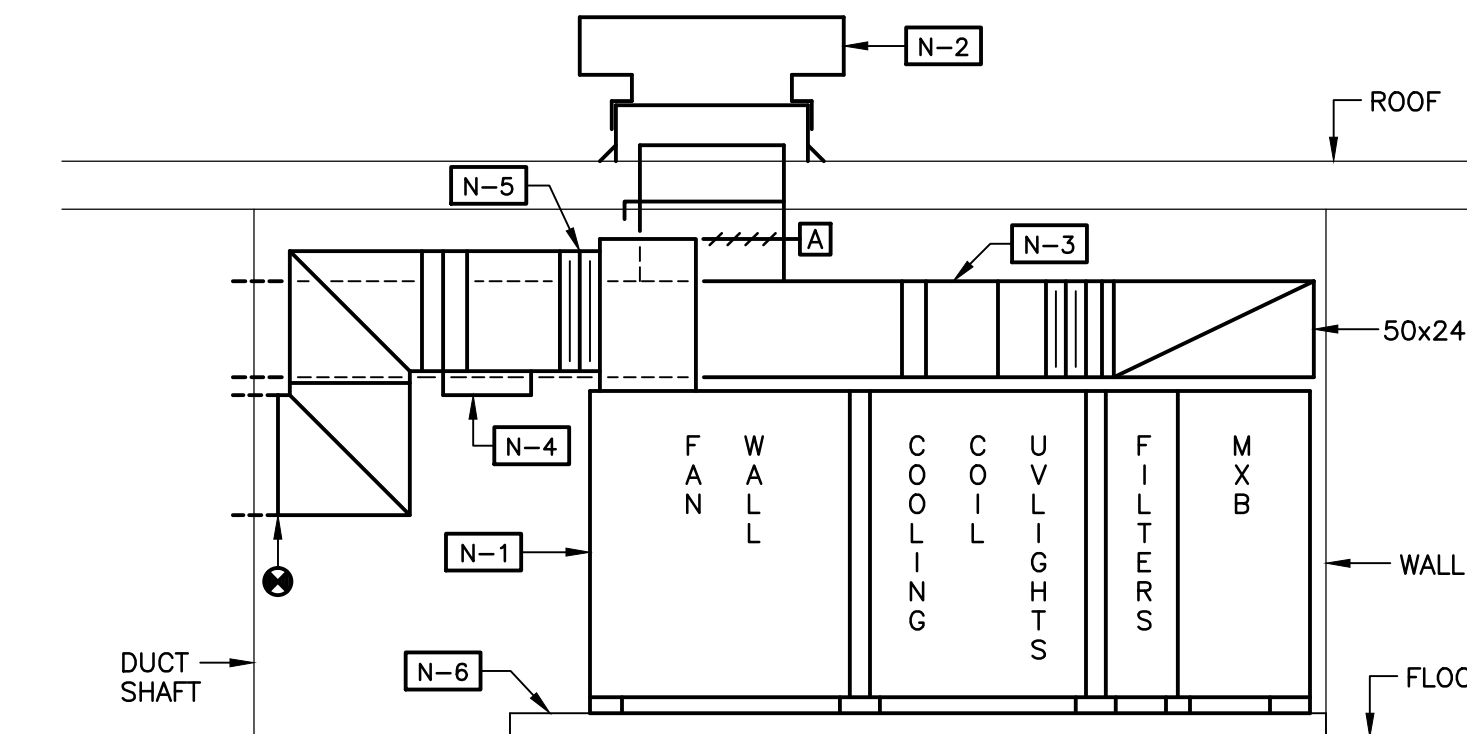

MECHANICAL ROOM 334 SECTION (A)

SCALE: 1/4" = 1'-0"

SECTION NOTES:











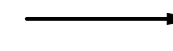
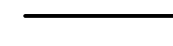

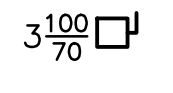
- N-1** NEW HORIZONTAL STYLE CHILLED WATER AIR HANDLING UNIT WITH ACCESS DOORS, UV LIGHTS AND FAN WALL TECHNOLOGIES.
- N-2** ROOF MOUNTED O.A. INTAKE WITH ROOF CURB. 36"x36" O.A. DUCT DOWN WITH AUTOMATIC CONTROL DAMPER. CONNECT TO BUILDING RETURN DUCT.
- N-3** 40KW DUCT MOUNTED ELECTRIC PREHEAT COIL.
- N-4** ZONE ELECTRIC HEATING COIL - TYP.
- N-5** DUCTWORK FLEXIBLE CONNECTION ALL ZONES - TYP.
- N-6** EXISTING AHU HOUSEKEEPING PAD.



GENERAL NOTES

- ELECTRICAL WORK SHALL COMPLY WITH ALL APPLICABLE CODES AS ENFORCED BY THE AUTHORITIES HAVING JURISDICTION, INCLUDING (BUT NOT LIMITED TO): 2017 FLORIDA BUILDING CODE, SIXTH EDITION; 2018 FLORIDA FIRE PREVENTION CODE, SIXTH EDITION; 2014 NFPA 70 NATIONAL ELECTRICAL CODE; 2013 NFPA 72 NATIONAL FIRE ALARM CODE; 2020 UF DESIGN AND CONSTRUCTION STANDARDS.
- ALL NEW ELECTRICAL EQUIPMENT AND DEVICES SHALL BE UL LISTED.
- COMPLY WITH UF FH&S HOT WORK SAFETY POLICY: SEE <http://www.efs.ufl.edu/programs/os/hotwork/>; UF HOT WORK PERMIT FORM: SEE http://www.efs.ufl.edu/hotwork_permit.pdf
- PROVIDE ALL MATERIALS AND EQUIPMENT AND PERFORM ALL LABOR REQUIRED TO INSTALL COMPLETE AND OPERABLE ELECTRICAL SYSTEMS AS INDICATED ON THE DRAWINGS, AS SPECIFIED AND AS REQUIRED BY CODE.
- COORDINATE ALL WORK WITH APPROVED SHOP DRAWINGS AND MANUFACTURERS' RECOMMENDATIONS. COORDINATE WORK WITH OTHER TRADES.
- PROVIDE ALL MOUNTING HARDWARE AND SUPPORTS AS REQUIRED.
- CONTRACT DOCUMENT DRAWINGS FOR ELECTRICAL WORK ARE DIAGRAMMATIC AND ARE INTENDED TO CONVEY SCOPE AND GENERAL ARRANGEMENT ONLY.
- PRIOR TO BID THE CONTRACTOR SHALL BE RESPONSIBLE FOR REVIEWING EXISTING SITE CONDITIONS AND REPORTING TO THE ENGINEER ANY CONDITION THAT WILL PROHIBIT, ADD TO, OR REQUIRE MODIFICATION OF, THE WORK INDICATED ON THE CONSTRUCTION DOCUMENTS. BID SHALL ACCOUNT FOR WORK DIFFICULTIES RELATED TO EXISTING SITE CONDITIONS.
- EXISTING ELECTRICAL ITEMS NOT INTENDED FOR REMOVAL SHALL BE MAINTAINED IN PRESENT CONDITION AND STATE OF OPERATION THROUGH-OUT CONSTRUCTION. ANY DISRUPTION OF OPERATION REQUIRED FOR INSTALLATION OF NEW WORK SHALL BE PLANNED TO BE BRIEF AS POSSIBLE AND ARRANGED AT LEAST TWO WEEKS IN ADVANCE WITH THE OWNER.
- PERFORM COMPLETE DEMOLITION OF EXISTING ELECTRICAL ITEMS AS INDICATED. RE-USE ITEMS ONLY AS DIRECTED ON DRAWINGS OR BY OWNER. REMOVE ALL ABANDONED WIRING; SEAL UP ALL UNUSED OPENINGS IN WALLS, FLOORS AND ELECTRICAL EQUIPMENT AS REQUIRED.
- SEAL RACEWAY PENETRATIONS THROUGH FIRE RATED WALLS AND FLOORS WITH METACALK FIRESTOPPING SYSTEM, MATCH EXISTING STRUCTURE FIRE RATING.
- ALL ELECTRICAL EQUIPMENT, DEVICES, WIRING, RACEWAY, ETC., SHOWN ON PLANS SHALL BE NEW UNLESS NOTED OTHERWISE.
- DASHED LINES DENOTE EXISTING ITEMS.
- POWER CONDUCTORS SHALL BE COPPER WITH 90°C THHN/THWN-2 INSULATION, #12 AWG MINIMUM AND BE ENCLOSED IN METAL RACEWAY. TIC MARKS ALONG RACEWAYS INDICATE NEUTRAL (LONG MARKS) AND PHASE (SHORT MARK) CONDUCTORS WHEN MORE THAN 1 OF EITHER ARE PRESENT. PROVIDE GROUND WIRE IN ALL POWER RACEWAYS (NOT SHOWN).
- PROVIDE SEPARATE NEUTRAL FOR ALL 120V. AND 277V. CIRCUITS. NEUTRAL SHALL BE IDENTIFIED BY ASSOCIATED CIRCUIT NUMBER AT ALL TERMINATIONS, SPLICES AND WITHIN ALL JUNCTION/OUTLET BOXES.
- LABEL ALL POWER RACEWAYS WITH VOLTAGE, PANEL NAME AND CIRCUIT NUMBER AT 10' INTERVALS. LABEL ALL DISCONNECT SWITCHES WITH EQUIPMENT SERVED, VOLTAGE, PANEL/SWITCHBOARD NAME AND CIRCUIT NUMBER. TAG ALL POWER WIRES AT JUNCTION BOXES AND AT ALL TERMINATIONS WITH PANEL/SWITCHBOARD NAME AND CIRCUIT NUMBER.
- ALL NEW RACEWAY/WIRING SHALL BE CONCEALED IN WALL AND/OR CEILING WHEREVER PRACTICAL IN FINISHED AREAS.
- FINAL CONNECTIONS TO MECHANICAL OR MOTORIZED EQUIPMENT SHALL BE LIQUIDTIGHT FLEXIBLE METAL CONDUIT.
- REFER TO MECHANICAL DRAWINGS AND SUBMITTALS PRIOR TO ROUGH-IN FOR LOCATIONS OF EQUIPMENT AND EQUIPMENT CONNECTION DETAILS.
- UPDATE EXISTING PANEL DIRECTORIES TO REFLECT BRANCH CIRCUIT REVISIONS.
- PROVIDE NEW FIRE ALARM WIRING PER MANUFACTURERS RECOMMENDATIONS AND ENCLOSED IN METAL RACEWAY. MATCH EXISTING WIRING COLOR CODE.
- PAINT FIRE ALARM JUNCTION BOXES AND RACEWAY RED.
- THE NEW DUCT SMOKE DETECTORS SHALL NOT INITIATE A BUILDING-WIDE ALARM WHEN ACTIVATED. THEY SHALL PERFORM A SHUT DOWN OF THE ASSOCIATED HVAC AIR HANDLER UNIT AND INITIATE AN AUDIBLE AND VISUAL TROUBLE SIGNAL AT THE FACP. THIS SIGNAL SHALL ALSO BE SENT TO UFPD.
- PROVIDE PRODUCT SUBMITTALS FOR ALL ELECTRICAL EQUIPMENT AND MATERIALS TO ENGINEER FOR REVIEW.
- PROVIDE OPERATION AND MAINTENANCE MANUALS AT PROJECT CLOSE OUT PRIOR TO FINAL INSPECTION. INCLUDE WIRING DIAGRAMS, CONTROL DIAGRAMS, WARRANTIES, ETC. PROVIDE ONE PAPER COPY O&M'S AND ELECTRONIC MEDIA.
- MAINTAIN AND SUBMIT RECORD DRAWINGS OF AS-BUILT CONDITIONS.
- THE CONTRACTOR SHALL GUARANTEE ALL MATERIALS, EQUIPMENT AND WORKMANSHIP AGAINST DEFECTS FOR ONE YEAR FROM THE DATE OF FINAL ACCEPTANCE AND SHALL CORRECT ANY DEFECTS AT NO ADDITIONAL COST TO THE OWNER.
- ALL FUSED DISCONNECT SWITCHES SHALL HAVE SPARE FUSES. PROVIDE CONTAINER MARKED "SPARE FUSES" AND MOUNT ADJACENT TO DISCONNECT SWITCH.

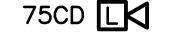
LEGEND

| | |
|---|---|
|  | BRANCH CIRCUIT OR FEEDER HOME-RUN TO SOURCE INDICATED |
|  | RACEWAY |
|  | LIQUIDTIGHT FLEXIBLE METAL CONDUIT |
|  | HEAVY DUTY DISCONNECT SWITCH. LARGE # DENOTES POLES. TOP # DENOTES AMP RATING / BOTTOM # DENOTES FUSE RATING - "NF" DENOTES NON-FUSED. MANUFACTURERS: SQUARE D, GENERAL ELECTRIC, SIEMENS, CUTLER HAMMER. ALL FUSED DISCONNECT SWITCHES SHALL HAVE SPARE FUSES. PROVIDE CONTAINER MARKED "SPARE FUSES" AND MOUNT ADJACENT TO DISCONNECT SWITCH. |
|  | VARIABLE SPEED DRIVE FURNISHED BY HVAC CONTRACTOR, INSTALLED AND WIRED BY ELECTRICAL CONTRACTOR. |
|  | JUNCTION BOX |
|  | MOTOR CONNECTION |
|  | ELECTRICAL CONNECTION. |
|  | DUCT MOUNTED SMOKE DETECTOR; DUCT SENSOR HOUSING; SAMPLING TUBE. MATCH EXISTING DEVICES. |
|  | FIRE ALARM CONTROL RELAY. |
|  | REMOTE MOUNTED DUCT SMOKE DETECTOR TEST STATION WITH KEY SWITCH AND RED LED ALARM INDICATOR. PROVIDE SINGLE GANG STAINLESS STEEL COVERPLATE AND LABEL. MOUNT IN ACCESSIBLE LOCATION. |
|  | FIRE ALARM HORN/STROBE UNIT - A.D.A. COMPLIANT; ENTIRE STROBE LENS SHALL NOT BE LESS THAN 80" A.F.F. AND NOT GREATER THAN 96" A.F.F.; 75CD INDICATES CANDELA RATING. MATCH EXISTING DEVICES. PROVIDE BOX AND ADAPTER PLATE ACCESSORIES FOR SURFACE MOUNTING. |
|  | EXISTING FIRE ALARM CONTROL PANEL TO REMAIN, MANUF. BY EST (QS1 SERIES). PROVIDE NEW COMPONENTS AS REQUIRED TO ACCOMMODATE NEW DEVICES. PROVIDE WIRING TO NEW DEVICES PER MANUFACTURERS RECOMMENDATIONS. |
|  | PLAN NOTE REFERENCE |

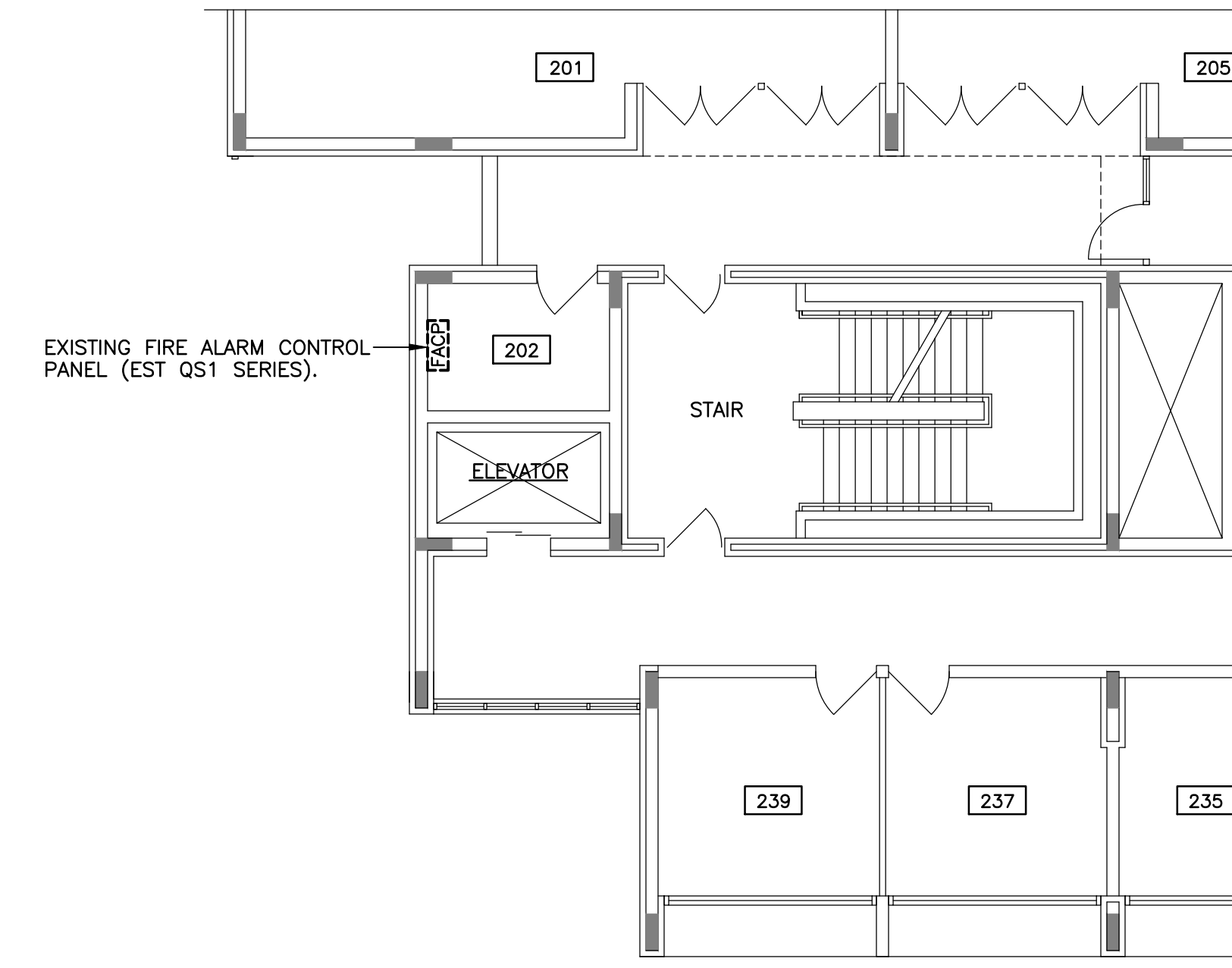

PARTIAL SECOND FLOOR ELECTRICAL PLAN

SCALE: 1/8" = 1'-0"

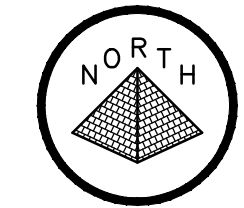

ABBREVIATIONS

| | |
|--|---|
| A. - AMPERES | KAIC - KILOAMPERE INTERRUPTING CAPACITY |
| BKR. - BREAKER | KVA - KILOVOLT-AMPERES |
| C. - CONDUIT | M.C.B. - MAIN CIRCUIT BREAKER |
| CKT. - CIRCUIT | M.L.O. - MAIN LUGS ONLY |
| EF - EXHAUST FAN | N. - NEUTRAL |
| FACP - FIRE ALARM CONTROL PANEL | N.E.C. - NATIONAL ELECTRICAL CODE |
| G./GND. - GROUND | ∅ - PHASE |
| HVAC - HEATING, VENTILATING & AIR CONDITIONING | P. - POLE |
| HP - HORSEPOWER | V. - VOLTS |
| | VA - VOLT-AMPERES |

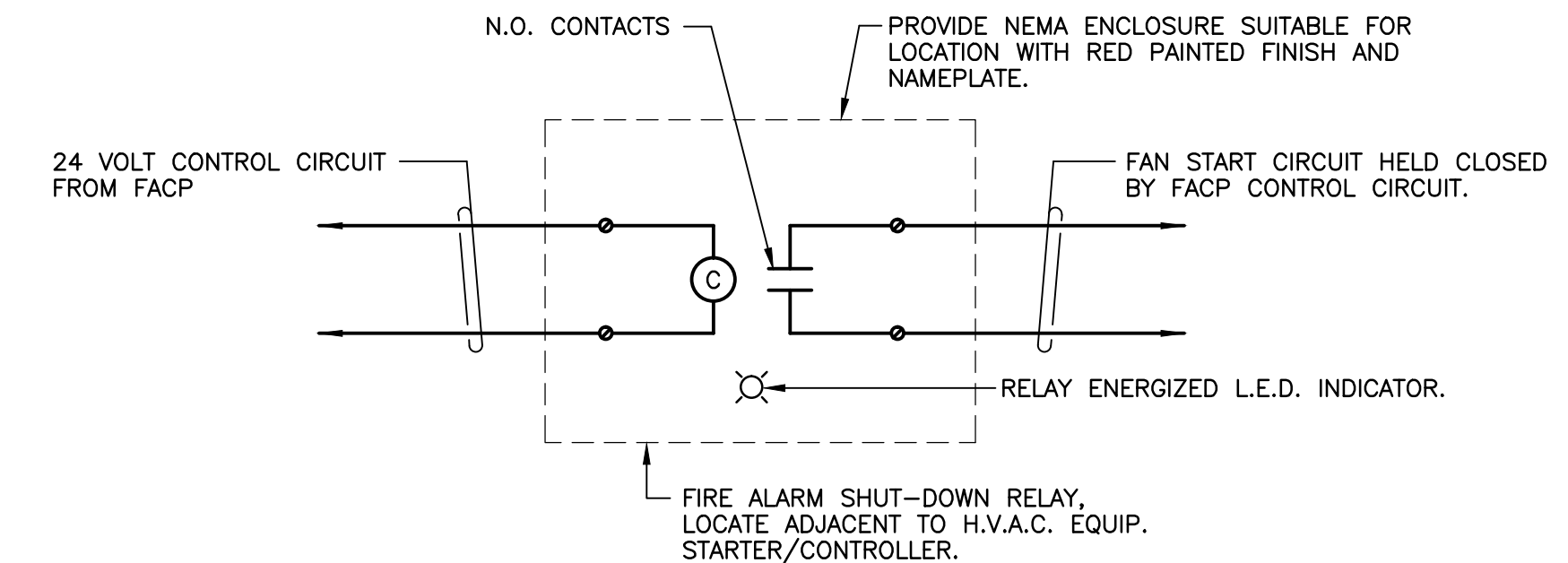

FIRE ALARM SHUT-DOWN RELAY SCHEMATIC

NOT TO SCALE

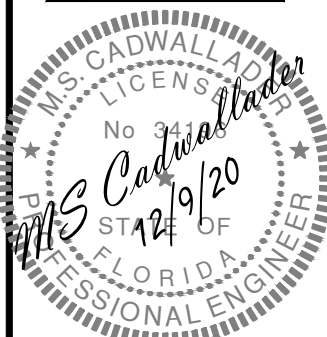

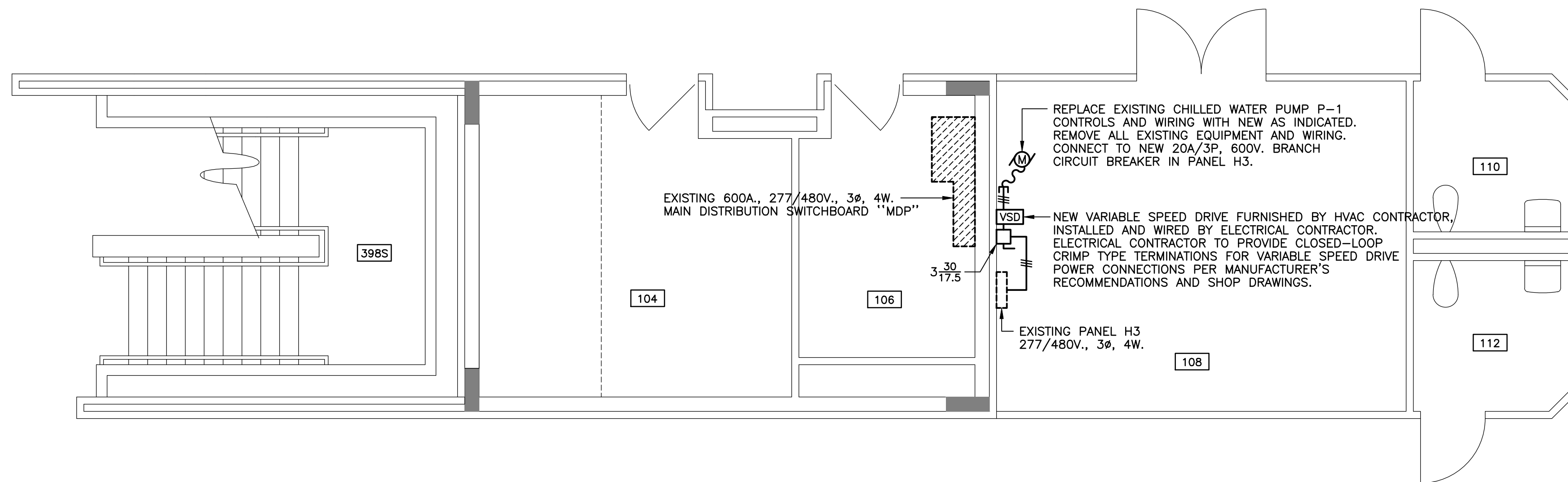

PARTIAL FIRST FLOOR ELECTRICAL PLAN

SCALE: 1/4" = 1'-0"

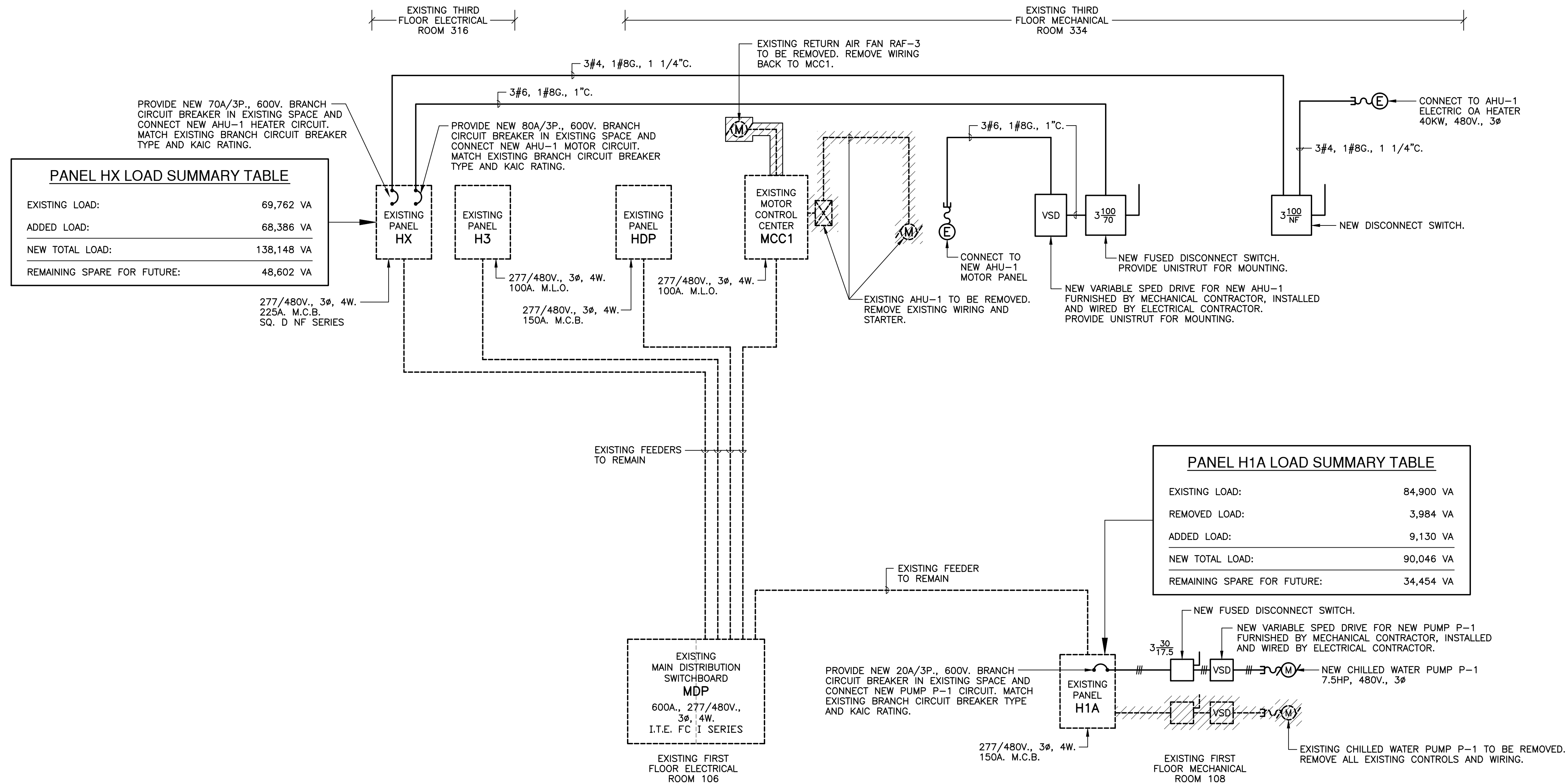
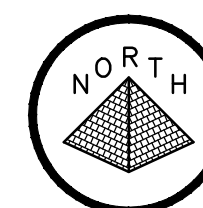

| PANEL HX LOAD SUMMARY TABLE | |
|-----------------------------|------------|
| EXISTING LOAD: | 69,762 VA |
| ADDED LOAD: | 68,386 VA |
| NEW TOTAL LOAD: | 138,148 VA |
| REMAINING SPARE FOR FUTURE: | 48,602 VA |

| PANEL H1A LOAD SUMMARY TABLE | |
|------------------------------|-----------|
| EXISTING LOAD: | 84,900 VA |
| REMOVED LOAD: | 3,984 VA |
| ADDED LOAD: | 9,130 VA |
| NEW TOTAL LOAD: | 90,046 VA |
| REMAINING SPARE FOR FUTURE: | 34,454 VA |

PARTIAL EXISTING POWER ONE-LINE DIAGRAM

NOT TO SCALE



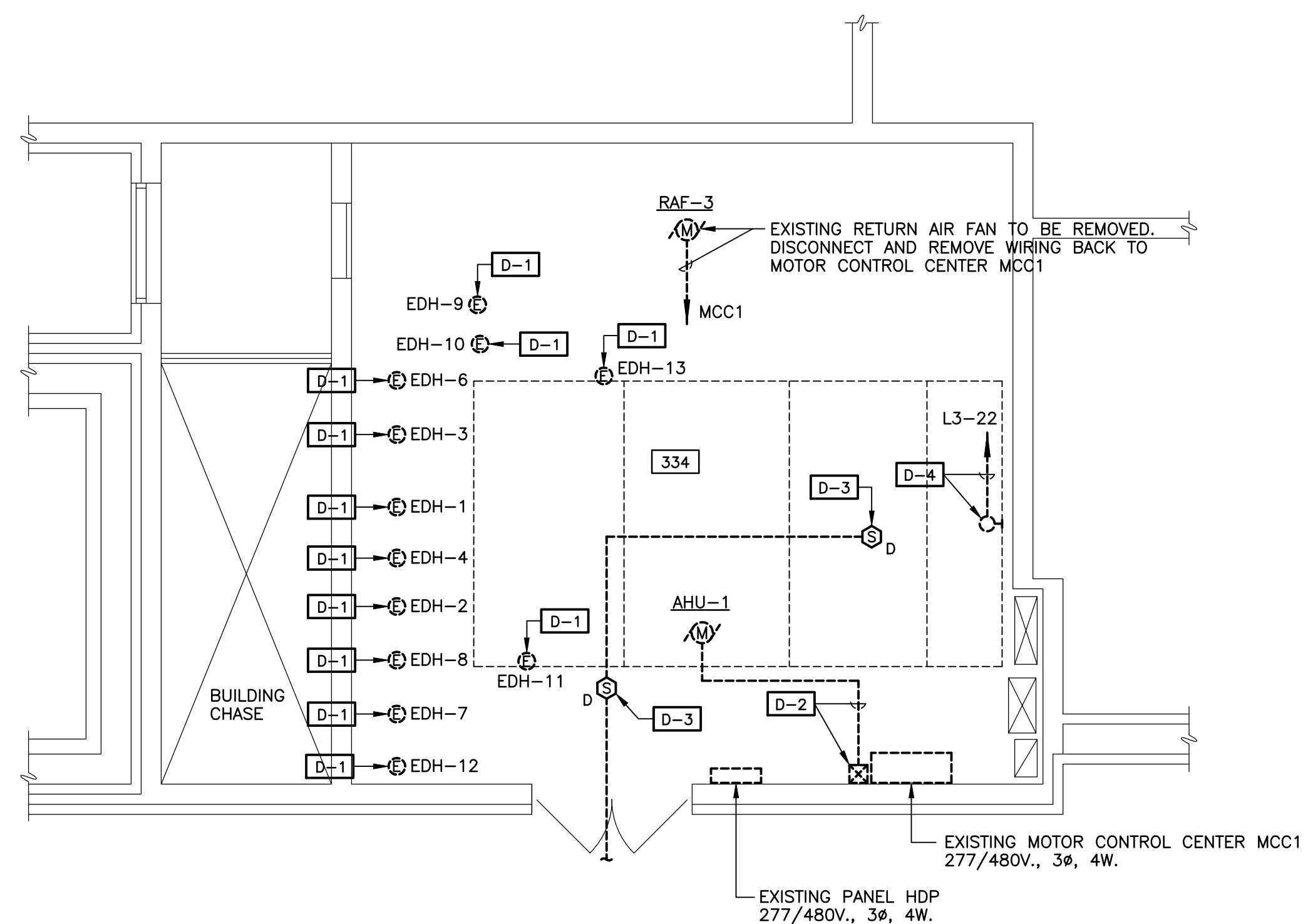

THIRD FLOOR MECHANICAL ROOM 334 ELECTRICAL DEMOLITION PLAN

SCALE: 1/4" = 1'-0"

DEMOLITION NOTES:

- D-1** EXISTING 480V., 3Ø ELECTRIC DUCT HEATERS TO BE REPLACED WITH NEW ELECTRIC DUCT HEATERS. DISCONNECT EXISTING DUCT HEATERS AND RECONNECT EXISTING CIRCUITS TO NEW DUCT HEATERS AS REQUIRED. DISCONNECT SWITCHES ARE FURNISHED WITH DUCT HEATERS. EXISTING CIRCUITS LISTED BELOW:
 EWH-1 SERVED BY PANEL HDP, CIRCUITS 1,3,5 (15A/3P)
 EWH-2 SERVED BY PANEL HDP, CIRCUITS 2,4,6 (15A/3P)
 EWH-3 SERVED BY PANEL HDP, CIRCUITS 7,9,11 (15A/3P)
 EWH-4 SERVED BY PANEL HDP, CIRCUITS 8,10,12 (15A/3P)
 EWH-5 SERVED BY PANEL HDP, CIRCUITS 13,15,17 (15A/3P)
 EWH-6 SERVED BY PANEL HDP, CIRCUITS 14,16,18 (15A/3P)
 EWH-7 SERVED BY PANEL HDP, CIRCUITS 19,21,23 (20A/3P)
 EWH-8 SERVED BY PANEL HDP, CIRCUITS 20,22,24 (15A/3P)
 EWH-9 SERVED BY PANEL HDP, CIRCUITS 25,27,29 (15A/3P)
 EWH-10 SERVED BY PANEL HDP, CIRCUITS 26,28,30 (25A/3P)
 EWH-11 SERVED BY PANEL HDP, CIRCUITS 31,33,35 (20A/3P)
 EWH-12 SERVED BY PANEL HDP, CIRCUITS 32,34,36 (15A/3P)
 EWH-13 SERVED BY PANEL HDP, CIRCUITS 2,4,6 (15A/3P)
 EWH-4 SERVED BY PANEL HDP, CIRCUITS 8,10,12 (15A/3P)
 EWH-7 SERVED BY PANEL HDP, CIRCUITS 14,16,18 (15A/3P)
 EWH-9 SERVED BY PANEL HDP, CIRCUITS 20,22,24 (15A/3P)
 EWH-11 SERVED BY PANEL HDP, CIRCUITS 26,28,30 (25A/3P)
 EWH-13 SERVED BY PANEL HDP, CIRCUITS 32,34,36 (15A/3P)
- D-2** REMOVE EXISTING AIR HANDLING UNIT AHU-1 STARTER AND WIRING BACK TO MCC1.
- D-3** REMOVE EXISTING DUCT SMOKE DETECTORS AND WIRING. PROVIDE NEW DUCT SMOKE DETECTOR AND WIRING AS INDICATED ON NEW ELECTRICAL PLAN. THE EXISTING FIRE ALARM CONTROL PANEL (EST QS1 SERIES) IS LOCATED IN SECOND FLOOR ROOM 202, SEE PARTIAL SECOND FLOOR ELECTRICAL PLAN ON SHEET E-1.
- D-4** DISCONNECT EXISTING AHU-1 LIGHT, REUSE EXISTING 120V. CIRCUIT (L3-22) FOR NEW AHU-1 LIGHTS AS SHOWN ON NEW PLAN.

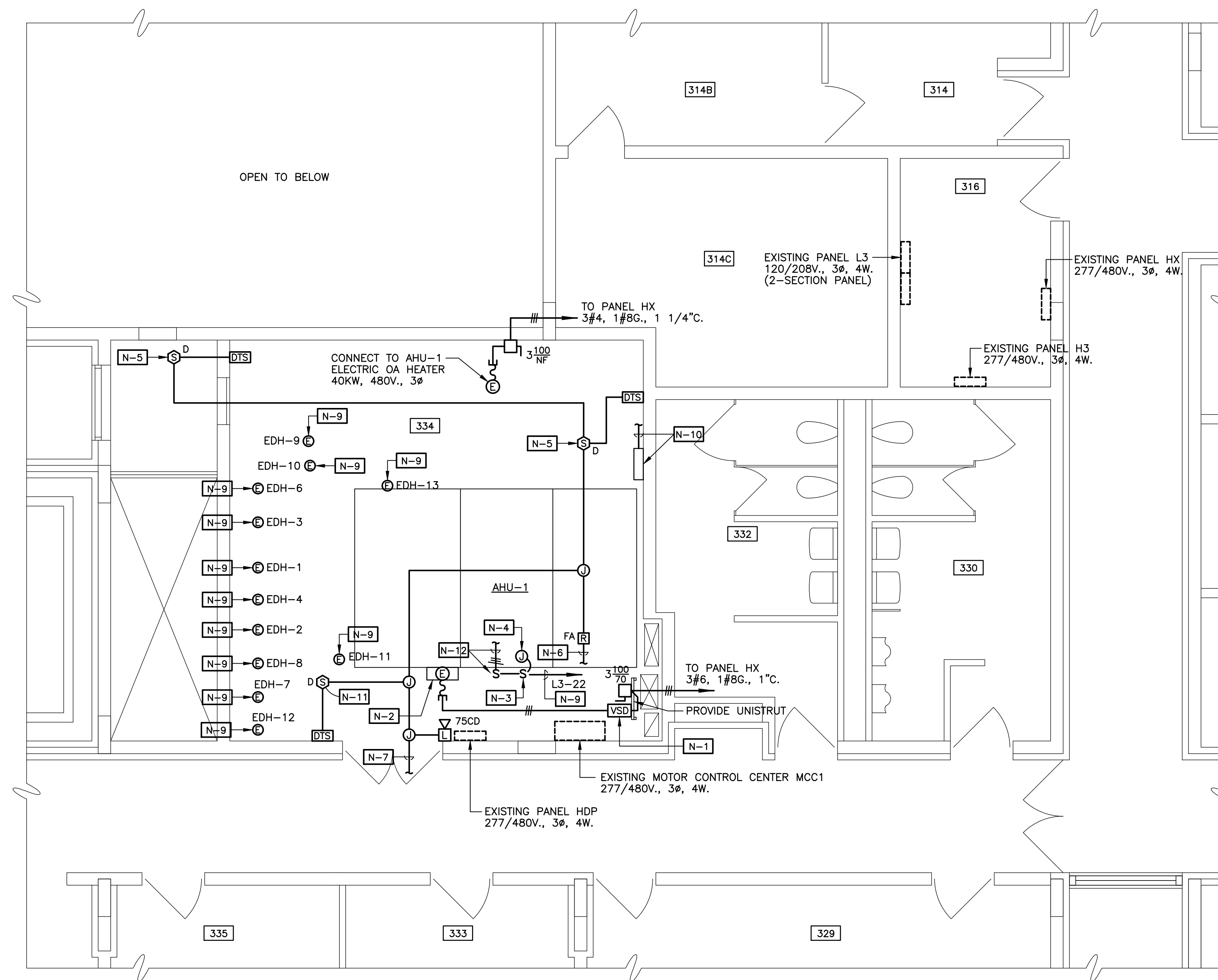
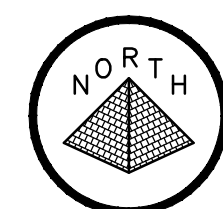

PARTIAL THIRD FLOOR ELECTRICAL PLAN

SCALE: 1/4" = 1'-0"

PLAN NOTES:

- N-1** NEW VARIABLE SPEED DRIVE FURNISHED BY HVAC CONTRACTOR, INSTALLED AND WIRED BY ELECTRICAL CONTRACTOR. ELECTRICAL CONTRACTOR TO PROVIDE CLOSED-LOOP CRIMP TYPE TERMINATIONS FOR VARIABLE SPEED DRIVE POWER CONNECTIONS PER MANUFACTURER'S RECOMMENDATIONS AND SHOP DRAWINGS.
- N-2** PANEL FURNISHED WITH AIR HANDLING UNIT CONTAINING MOTOR OVERLOAD PROTECTION AND DISCONNECTS FOR EACH AIR HANDLING UNIT FAN.
- N-3** NEW TOGGLE SWITCH FOR UV LIGHTS FURNISHED WITH AHU UNIT. ELECTRICAL CONTRACTOR TO MOUNT AND CONNECT PER MANUFACTURER RECOMMENDATIONS.
- N-4** NEW JUNCTION BOX FOR UV LIGHTS FURNISHED WITH AHU UNIT. ELECTRICAL CONTRACTOR TO CONNECT AS REQUIRED.
- N-5** MOUNT IN AIR HANDLING UNIT AHU-1 RETURN AIR DUCT, COORDINATE LOCATION WITH HVAC CONTRACTOR.
- N-6** TO AHU-1 CONTROLS FOR DUCT SMOKE DETECTOR SHUT-DOWN OF HVAC UNIT.
- N-7** CONNECT TO EXISTING FIRE ALARM SYSTEM AS REQUIRED. THE EXISTING FIRE ALARM CONTROL PANEL (EST QS1 SERIES) IS LOCATED IN SECOND FLOOR ROOM 202, SEE PARTIAL SECOND FLOOR ELECTRICAL PLAN ON SHEET E-1.
- N-8** EXISTING 480V., 3Ø ELECTRIC DUCT HEATERS TO BE REPLACED WITH NEW ELECTRIC DUCT HEATERS. DISCONNECT EXISTING DUCT HEATERS AND RECONNECT EXISTING CIRCUITS TO NEW DUCT HEATERS AS REQUIRED. NEW DISCONNECT SWITCHES ARE FURNISHED WITH NEW DUCT HEATERS. EXISTING CIRCUITS LISTED BELOW:
 EWH-1 SERVED BY PANEL HDP, CIRCUITS 1,3,5 (15A/3P)
 EWH-2 SERVED BY PANEL HDP, CIRCUITS 2,4,6 (15A/3P)
 EWH-3 SERVED BY PANEL HDP, CIRCUITS 7,9,11 (15A/3P)
 EWH-4 SERVED BY PANEL HDP, CIRCUITS 8,10,12 (15A/3P)
 EWH-5 SERVED BY PANEL HDP, CIRCUITS 13,15,17 (15A/3P)
 EWH-6 SERVED BY PANEL HDP, CIRCUITS 14,16,18 (15A/3P)
 EWH-7 SERVED BY PANEL HDP, CIRCUITS 19,21,23 (20A/3P)
 EWH-8 SERVED BY PANEL HDP, CIRCUITS 20,22,24 (15A/3P)
 EWH-9 SERVED BY PANEL HDP, CIRCUITS 25,27,29 (15A/3P)
 EWH-10 SERVED BY PANEL HDP, CIRCUITS 26,28,30 (25A/3P)
 EWH-11 SERVED BY PANEL HDP, CIRCUITS 31,33,35 (20A/3P)
 EWH-12 SERVED BY PANEL HDP, CIRCUITS 32,34,36 (15A/3P)
 EWH-13 SERVED BY PANEL HDP, CIRCUITS 2,4,6 (15A/3P)
 EWH-4 SERVED BY PANEL HDP, CIRCUITS 8,10,12 (15A/3P)
 EWH-7 SERVED BY PANEL HDP, CIRCUITS 14,16,18 (15A/3P)
 EWH-9 SERVED BY PANEL HDP, CIRCUITS 20,22,24 (15A/3P)
 EWH-11 SERVED BY PANEL HDP, CIRCUITS 26,28,30 (25A/3P)
 EWH-13 SERVED BY PANEL HDP, CIRCUITS 32,34,36 (15A/3P)
- N-9** REUSE EXISTING AHU-1 120V. LIGHT CIRCUIT (L3-22) FOR NEW AHU-1 LIGHTS AND RECEPT. AS REQUIRED.
- N-10** NEW TEMPERATURE CONTROL PANEL BY HVAC CONTRACTOR. CONNECT TO EXISTING 120V. HVAC CONTROLS CIRCUIT AS REQUIRED.
- N-11** MOUNT IN AIR HANDLING UNIT AHU-1 SUPPLY AIR DUCT, COORDINATE LOCATION WITH HVAC CONTRACTOR.
- N-12** CONNECT TO LIGHT SWITCH, (8)15W. LED WORK LIGHTS AND GFI DUPLEX RECEPTACLE FURNISHED WITH AHU-1 AS REQUIRED. COORDINATE WITH HVAC CONTRACTOR AND APPROVED SHOP DRAWINGS.

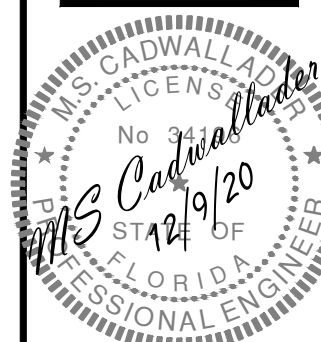

DATE: 12/9/20
DRAWN: JRW
APPROVED: MSC

1823

E-3

OF 3 SHEETS

BIDDING DOCUMENTS